

CLAS15B SINK MIXER

Notes:

- Solid brass construction
- Watermark approved; complies with AS/NZS 3718:2005
- Installation instructions and all parts included
- 15 year warranty

Finishes:

- Brushed nickel
- Brushed gunmetal

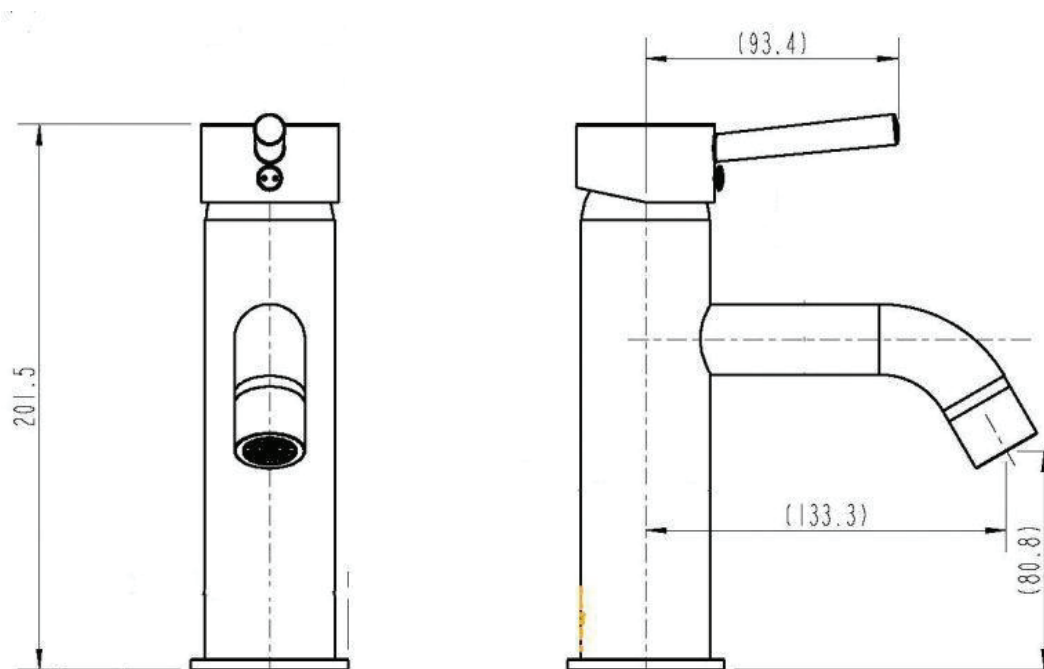

AUSTRALIA

Phone: 1800 462 946
 Email: sales@stonebaths.com.au
 Web: stonebaths.com.au

NEW ZEALAND

0800 001 872
 Email: sales@stonebaths.co.nz
 Web: stonebaths.co.nz