

# HUGI

S T O N E B A T H S

AUSTRALIA  
Phone: 1800 462 946  
Email: info@stonebaths.com.au  
Web www.stonebaths.com.au

NEW ZEALAND  
Phone: 0800 001 872  
Email: info@stonebaths.co.nz  
Web www.stonebaths.com.au

 **stonebaths**  
Industry leaders since 2004

## Hugi B050-A 1800mm Freestanding Bath

### Notes:

- Matte white polymarble
- With overflow
- 10 year manufacturers warranty

**Size:** 1800 x 800 x 640(mm)

### Finishes:

- Matte white
- Gloss white
- Colour

### Options:

- Stone waste

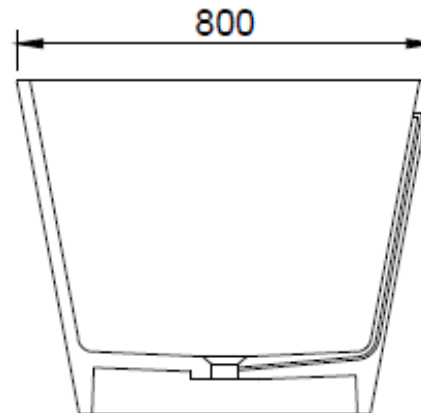
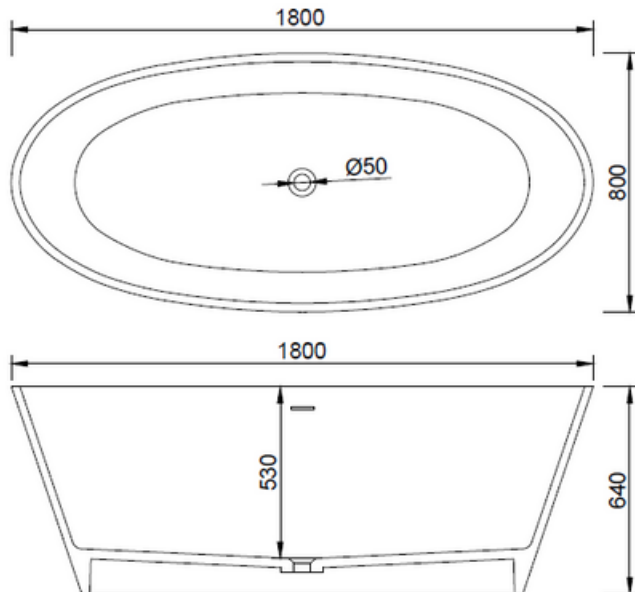

Net Weight: 155kg  
Gross Weight: 232kg  
Water capacity: 420L  
Unit: mm  
5-10mm tolerance