

# The CINK

## User Manual

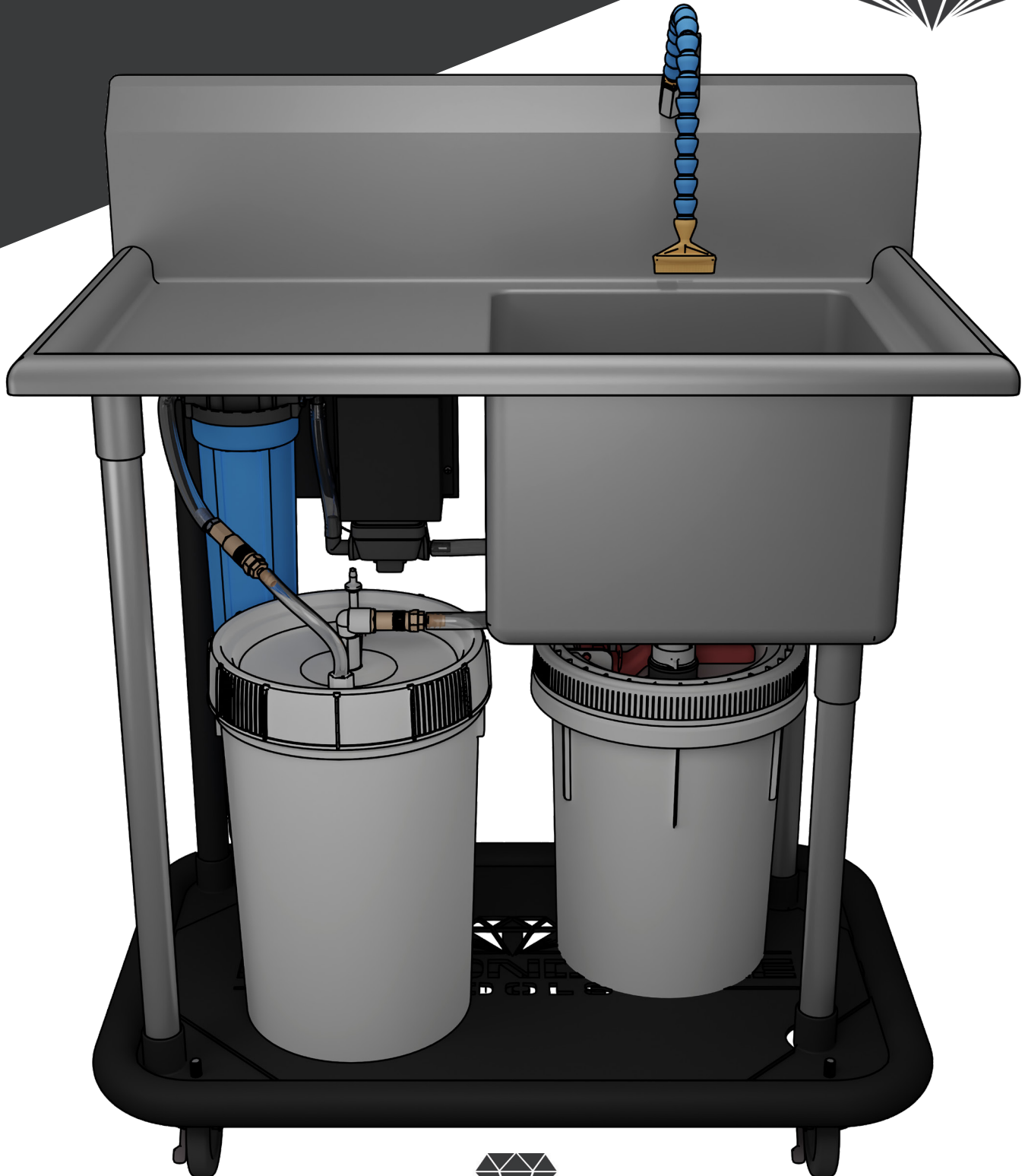



## CONTENTS

Introduction .....	2
Safety Precautions .....	3
Quick Start.....	4
Operation.....	6
Maintenance .....	7
Troubleshooting.....	11
Frequently Asked Questions .....	12
Parts & Accessories.....	13
Warranty .....	13

## INTRODUCTION

The CINK is a complete, self-contained system for cleanup of clay, clay water, pottery tools and accessories. The system is designed to prevent clay from going down drains in plumbing or septic systems.



The CINK Classic



The CINK Deluxe



## SAFETY PRECAUTIONS

- Read this user manual completely before operating the unit.
- Follow all instructions and operating procedures.
- Avoid splashing water in eyes.
- Avoid splashing water on electrical components.
- Do not allow hoses to become bent or kinked.
- Do not leave the pump running for extended periods of time.
- Do not allow the pump to run “dry” without water in the system for more than 2 minutes.
- Do not allow the sink basin drain to become plugged while the system is running.
- Do not plug the drain of The CINK to fill the sink basin to wash parts.
- **CAUTION:** Use The CINK only in areas where if water spills it will not damage floors or carpeting, etc. Be aware that water may drip from hoses or spill when bucket lids or filters are removed.
- Position The CINK far away enough from electrical outlets so that water cannot splash on the outlet and plug.
- **WARNING!** Do not allow the power cord to lie in standing water at any time.
- Plug the power cord into a properly grounded, three-prong electric power outlet only.
- Protect the power cord from being damaged, pinched, bent, stepped on, rolled over, stretched, etc.
- **WARNING!** Do not use any other electrical appliances on or near The CINK to avoid any shock danger.
- When performing maintenance on The CINK, unplug the power cord from the electric outlet.
- Always leave The CINK unplugged during a lightning storm and when it is not in use.
- To reduce the risk of fire or electric shock, do not expose The CINK to outdoor elements such as rain, snow, etc.
- Remove all water and clay from the entire system before freezing conditions exist.
- Engage the wheel caster brakes to keep the unit from moving when it is plugged in or is in use.
- When moving the cart from one location to another:
  1. Unplug the power cord from the electrical outlet.
  2. Remove all items from The CINK or drainboard.
  3. Unlock the locking casters.
  4. Move carefully to avoid tipping the unit over.
  5. Relock the wheel casters when The CINK is in its new spot.
- Do not place any objects over 25 pounds on the unit or sit on or stand on this product as the unit may tip over. Objects placed on The CINK may fall, causing injury or damage to the user or to the unit.
- The CINK is to be used only with clean water to clean clay, pottery tools and brushes, slip water buckets, sponges, splash pans, etc. (water-soluble, clay product materials).
- **WARNING!** This CINK and system contain NON-POTABLE WATER. DO NOT DRINK THE WATER IN THIS UNIT AND THE SPRAY NOZZLE.
- **CAUTION:** DO NOT use The CINK for: beverages, food residue, bodily fluids, chemicals, oil-based materials, paints or glazes. The CINK is NOT designed for disposal or filtering of hazardous or biohazardous materials.
- Do not attempt to connect The CINK to any septic or sewer plumbing systems.
- Disposal of water and material collected in this system should be in accordance with local laws and regulations.
- **CAUTION:** Freezing conditions will damage The CINK (see Page 10).





## QUICK START

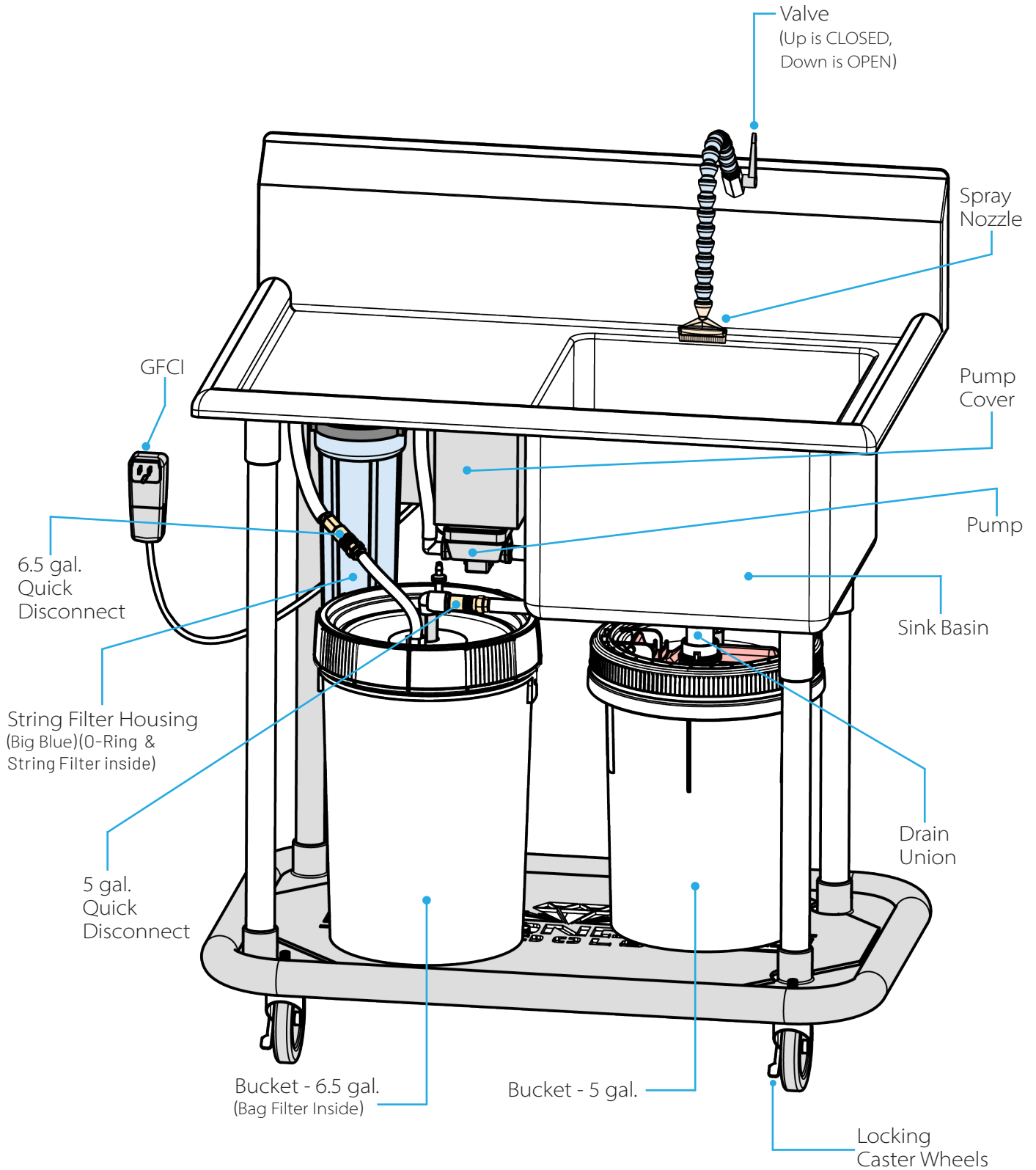



# QUICK START

1

Remove CINK from pallet. Position CINK near electrical outlet.

2

Separate the quick disconnects and the drain union to remove buckets.

3

Add fresh water to buckets. Stop at fill lines.

4

Screw on bucket lids. Be sure they are **STRAIGHT** and **TIGHT**.

5

Remove blue filter housing by turning to the left.

6

Check string filter and ensure O-ring is in place. Fill with water to top.

7

Reattach big blue housing. Be sure it is straight and tight. Turn right to tighten.

8

Reconnect tubes with quick disconnects.

9

Remove clear gasket taped to 5-gal. bucket lid. Insert gasket into drain union.

10

Connect drain union.

11

Open valve.

12

Plug in and let run for 1 minute.



## OPERATION

### Key Operating Steps

**1**

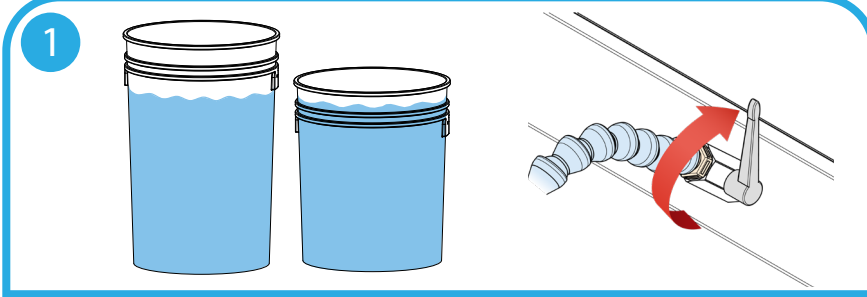

Check water levels and that faucet valve is closed (system won't function properly if 6.5-gal. bucket is below 1/3 full). With faucet valve CLOSED (handle upward), aim spray nozzle into sink basin.

**2**

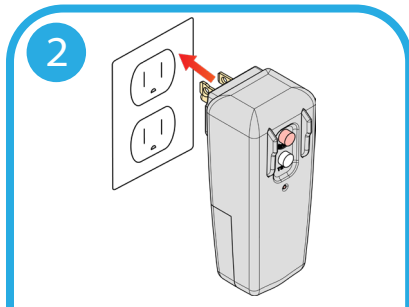

Plug GFCI power cord into 3-prong electric power outlet (observe safety cautions).

**3**

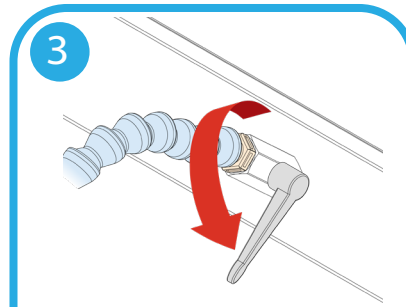

OPEN the faucet valve (handle down) to begin the flow of water.

**4**

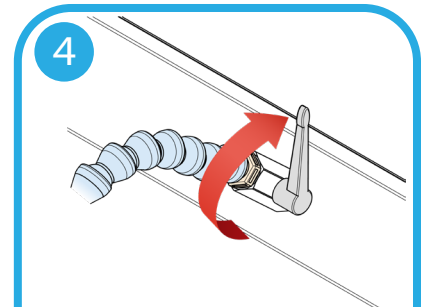

When finished, CLOSE the faucet valve (handle up).

**WARNING!** NEVER plug the sink basin drain and fill the basin with water to wash parts. This may cause the buckets to collapse if the pump keeps pumping. The CINK system is designed to function with continuous recirculation of water.

**Note:** Under heavy continuous use, water may become cloudy. If the system is allowed sedimentation time, finer particles will settle. You should periodically refresh the water in the system (at least once per week) after adequate sedimentation time is allowed. See Maintenance (Page 7) for instructions.

**Note:** Unplug The CINK if it will be left unattended for extended periods of time.



## MAINTENANCE

To maintain The CINK, you will need to empty the 5-gallon clay collection bucket, clean the filter bag and replace the string filter cartridge periodically. You may also need to winterize or prepare The CINK for periods of unused. Remember, as you perform these maintenance steps, small amounts of water may leak out from the system.

### **Emptying the 5-Gallon Clay Collection Bucket**

The 5-gallon bucket is intended to capture most of the clay and silt that will be put into The CINK. You will need to empty this bucket more frequently than cleaning or replacing the other two filters.

To empty the 5-gallon bucket when it has collected a significant amount of clay:

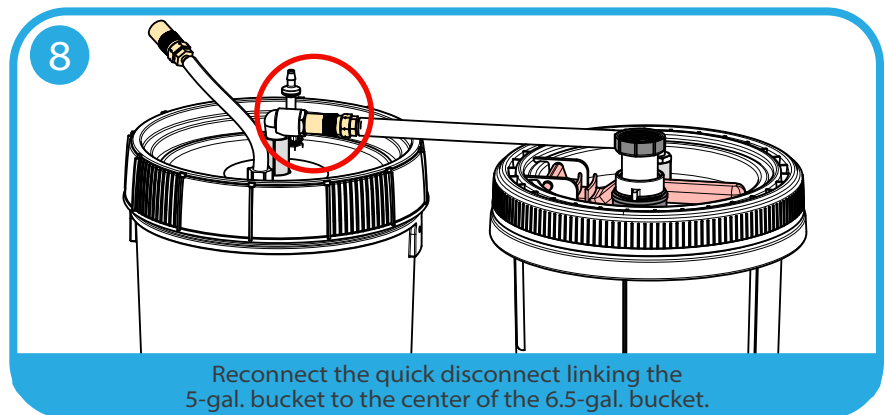
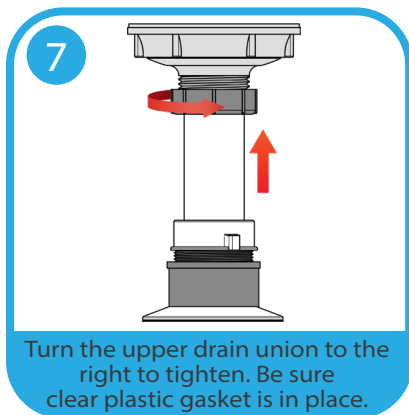
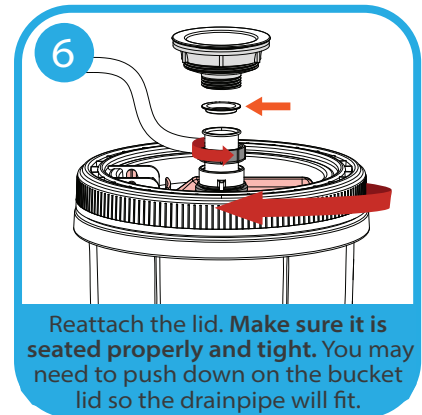
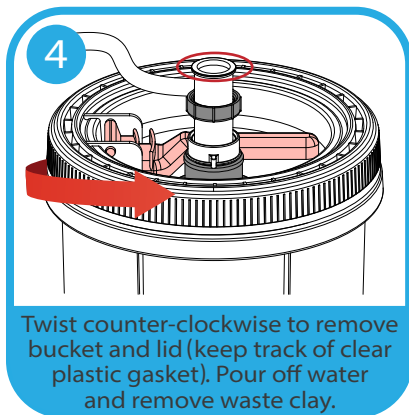
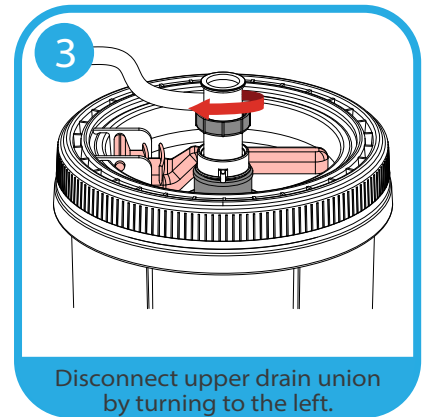
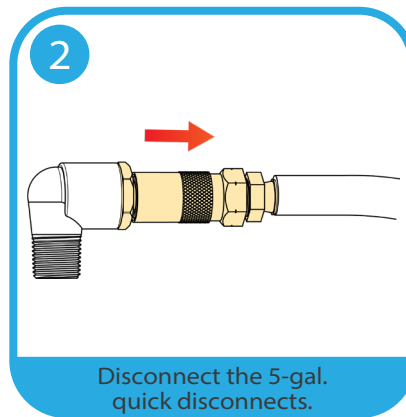
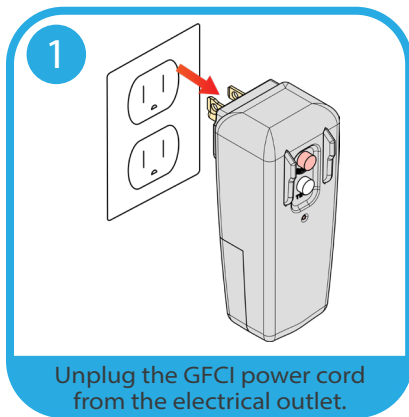



## Emptying the 6.5-Gallon Filtered Sediment Bucket and Cleaning the Filter Bag

The filter bag in the 6.5-gallon filtered sediment bucket is designed to stop particles and debris that are not settled out in the 5-gallon clay collection bucket (smaller bucket). This filter can usually be cleaned instead of replaced. The sediment level in the bottom of the 6.5-gallon bucket should not be allowed to get above 1 inch.

To empty the 6.5-gallon filtered sediment bucket and clean the filter bag:

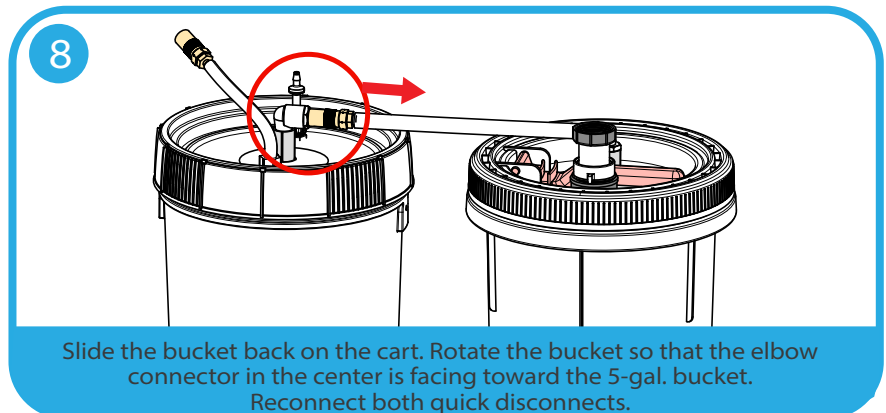
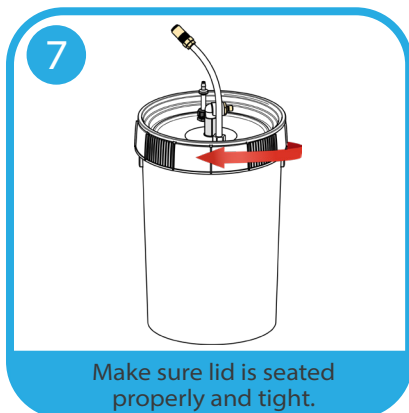
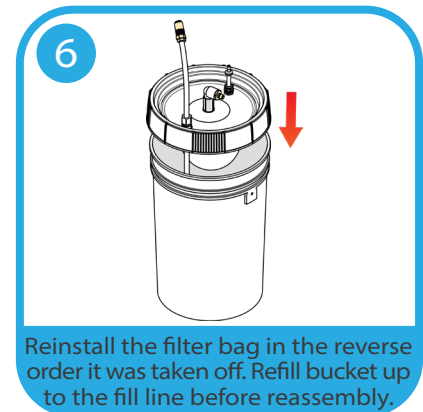
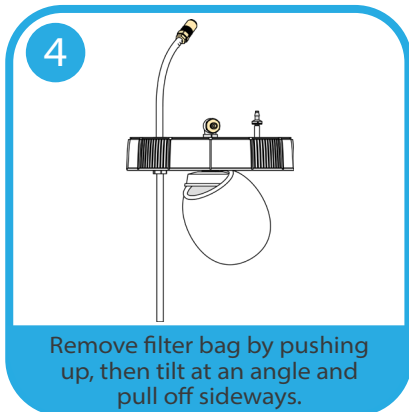
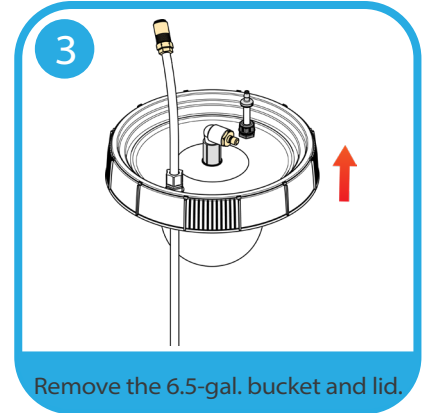
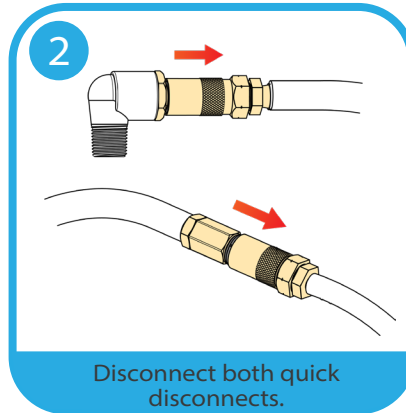
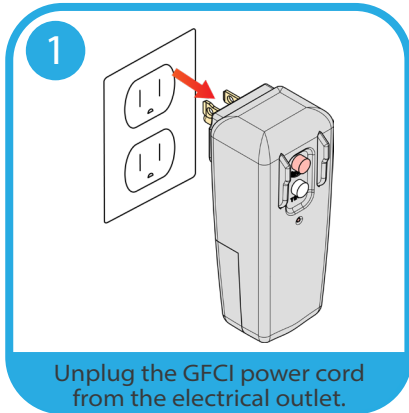





## Changing the Filter Cartridge in the Big Blue Filter

The big blue filter collects ultra-fine clay particles and should be cleaned at least every 3 months. Eventually, the pores of the filter cartridge will fill up and the water flow from the spray nozzle will decrease. At that time, please visit [www.DiamondCoreTools.com](http://www.DiamondCoreTools.com), call 619-905-9400 or email [info@diamondcoretools.com](mailto:info@diamondcoretools.com) to purchase replacement filters.

To change the filter cartridge:

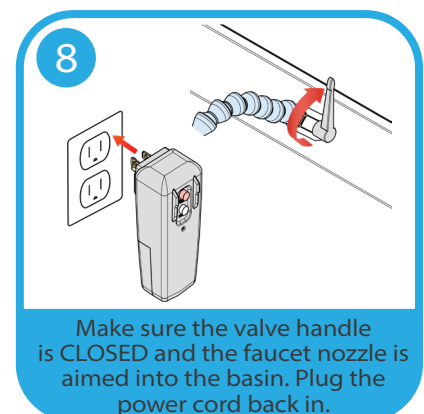
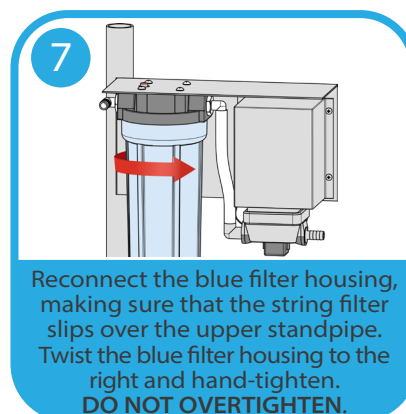
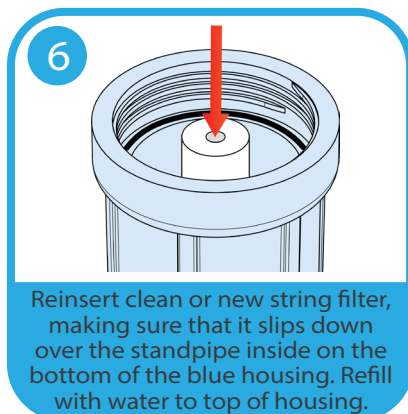
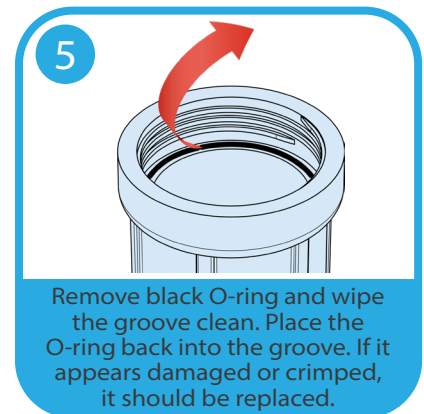
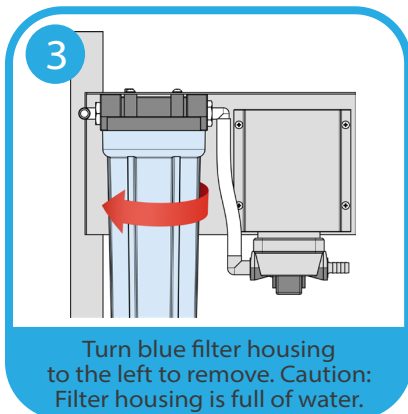
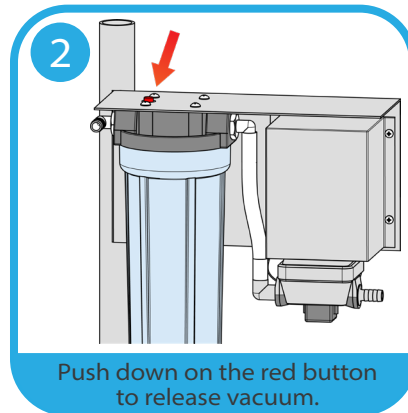
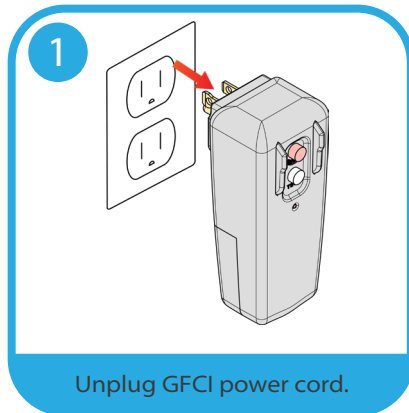



## Winterizing The CINK (Cold Weather or Freezing Conditions)

**CAUTION:** The CINK is NOT designed to operate or be stored with water or clay in it during freezing conditions. If freezing conditions are anticipated, remove all water and clay from the entire system. **The manufacturer is not responsible for any damage to the system, caused by the user, due to cold weather or freezing conditions.**

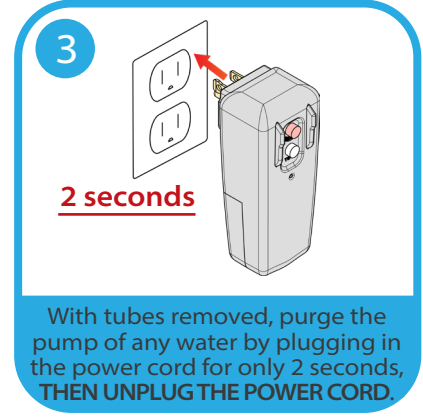
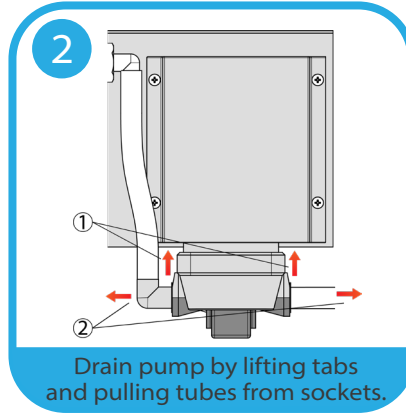

**Note:** After the system has had a chance to dry, be sure to plug the hose fittings back into the pump and press the blue or black lock tabs on the pump back down all the way.

## Extended Non-Use of The CINK

If you don't plan to use The CINK for an extended period, we recommend unplugging the unit, removing all water and clay from the system, cleaning the unit and allowing the filters to air dry. Follow instructions for Winterizing The CINK above.

## Water Cleanliness

You can eliminate odors in The CINK the same way you would with a slip bucket or clay trap. Because clay is an organic material, it can sometimes create mold and a sulfuric stink. A capful of bleach, done in moderation, will kill mold spores but won't affect reclaim. Chlorine from a pool supply store can also help mitigate the smell but isn't as effective at eliminating mold. Essential oils can be added but will mask the odor rather than address the root causes.

## Readjusting Drain Pipe Height

If water is leaking from the top of your drain pipe, it's likely that it isn't secured at the correct height with the drain union nut. To stop the leak, loosen both nuts, then realign the drain pipe at the correct height. To do so:

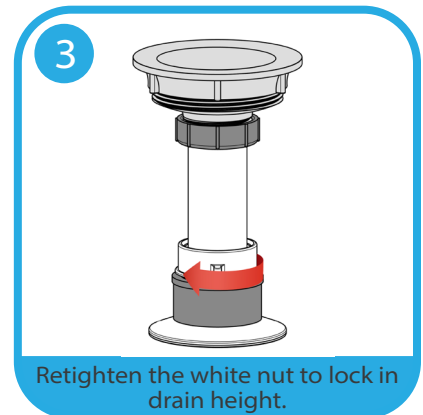
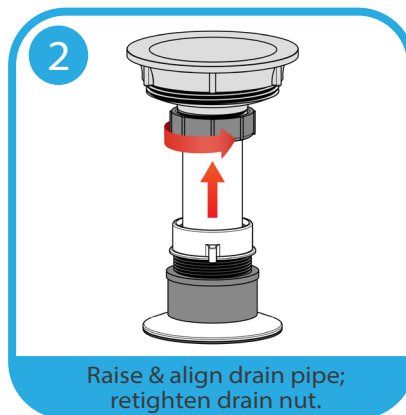
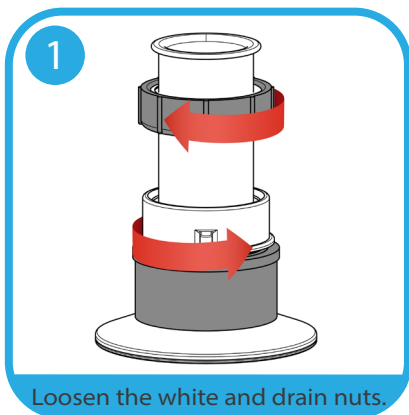



## TROUBLESHOOTING

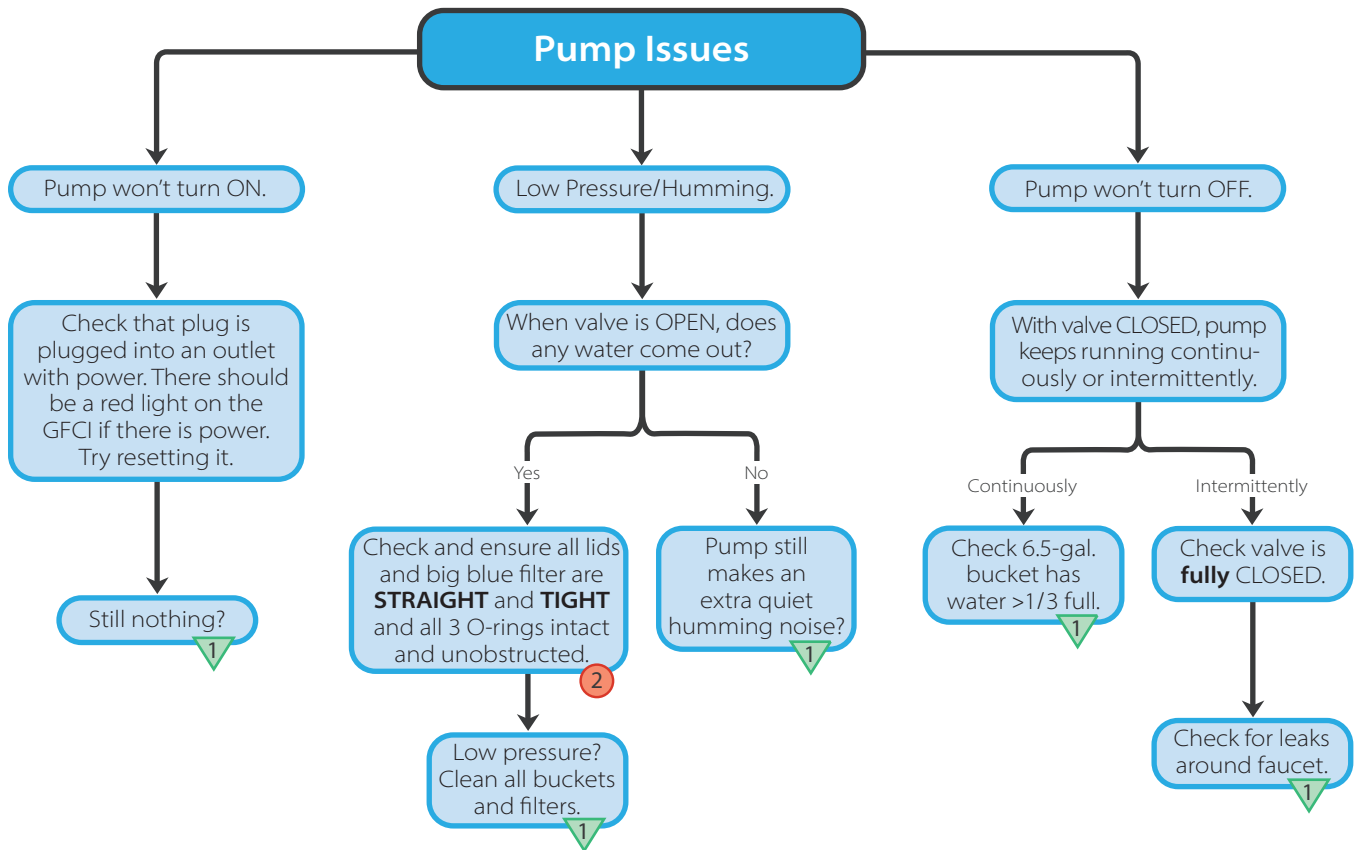

### Basin Not Draining

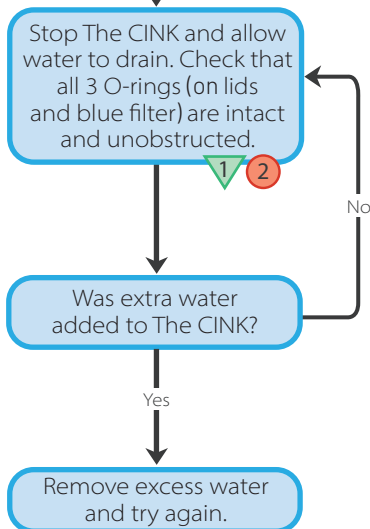

### Bucket Lid Leaking

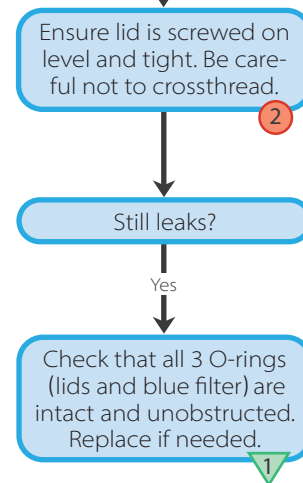

1 Still unresolved? Call us at 619-905-9400.

2 Repeat the step twice to potentially resolve the issue.



## FREQUENTLY ASKED QUESTIONS

---

**Q. Why is the basin not draining?**

- A.**
- Loose 6.5 gallon bucket lid
  - Damaged O-ring in either lid or blue filter housing
  - Clogged check valve (small tube on the 6.5 gallon lid)

**Q. How do I fix a leak in a bucket lid?**

- A.**
- Ensure lid is tight and seated properly
  - Check O-ring for damage

**Q. Why is water pooling on the top of the bucket lid?**

- A.**
- Loose fixtures
  - Debris in threads preventing proper seating
  - Damaged gasket on fixture

**Q. Why is the pump running when the faucet is closed?**

- A.**
- Insufficient water in system
  - If pulsing, there is a leak in the outlet hose or faucet
  - Damaged pump membrane (water leaking from pump)

**Q. Why is the water pressure low?**

- A.**
- Insufficient water in system
  - Air leak, generally at 6.5 gallon lid
  - Dirty or clogged string filter
  - Worn pump bearing (generally only on very old CINKs)

**Q. How can I mitigate the odor of the clay?**

- A.**
- Capful of bleach
  - Pool chlorine (do not mix with bleach)
  - Copper carbonate (glaze pigment)
  - Essential oil (will not address root cause)

**Q. The water out of the faucet is muddy; how can this be fixed?**

- A.**
- Clean string filter thoroughly
  - Clean bag filter thoroughly
  - Drain system and refresh water



### PARTS & ACCESSORIES

- The CINK Replacement String Filter: \$29
- The CINK Replacement Bag Filter: \$19
- The CINK Replacement Blue String Filter Canister: \$95
- The CINK Replacement Bucket O-Ring (2-pack): \$11.50
- The CINK Replacement Pump Kit: \$319
- The CINK Accessory Set 1: \$10

### For Replacement Parts

#### DiamondCore® Tools

680 W. Bradley Ave.  
El Cajon, CA 92020

Phone: 619-905-9400

Email: info@diamondcoretools.com

Website: www.diamondcoretools.com



### WARRANTY COVERAGE

DiamondCore® Tools warrants this product to be free from defects in materials and workmanship under normal use and service that would affect its operation for a period of 90 days from the date of purchase.

This warranty does not apply to:

- a) damage caused by accident, abuse, mishandling, dropping or tipping over
- b) units which have been subject to unauthorized repair
- c) units not used in accordance with directions
- d) damage exceeding the cost of the product
- e) damage by flood, lightning or natural disaster, or war declared or undeclared.

In no case shall the company be liable for any incidental or consequential damages for breach of this or any other warranty, express or implied whatsoever. The limit of this warranty includes the product only and not any loss of work time or contract due to inability to use this product.

**Order #**

---

**CINK Serial #**

---



Changing the World of **Ceramic Arts**  
**Glass Arts**  
**Lapidary Arts**  
**Wax Arts**  
**And More**