

INTENSE



2024//
SNIPER T PRO

MANUAL



Register your bike at:
www.intensecycles.com/pages/registerbike



SCAN ME

For Technical assistance:
 Email info@intensecycles.com /
 Phone +1 951-307-9211

THE INTENSE SNIPER T PRO

Whether you're racing cross-country against the world's best on the most demanding tracks, taking on an all day event, or tackling your local trail loop, the Sniper T is the down-country bike for you. With the Sniper T, we have created a pure full-suspension bike to tackle the most demanding XC tracks with a true INTENSE spirit.

#PURESPEEDMACHINE

CONTENTS

6	Components	30	Front suspension setup
8	Setup guide	32	Rear suspension setup
	<i>10 Remove wheels and prepare bike</i>	34	Final bike check
	<i>12 Install handlebars</i>	35	Geometry Chart
	<i>14 Install rear derailleur</i>	36	Maintenance Schedule
	<i>16 Install rear wheel</i>	37	Carbon care
	<i>20 Install front wheel</i>	38	Parts Listing
	<i>22 Install pedals</i>	40	Parts Kit
	<i>23 Wireless Gearing Set-up and Shifting Inspection</i>	42	Torque Specifications
	<i>24 Adjust headset and handlebar</i>		
	<i>26 Adjust saddle height, install bottle cage and check tire pressure</i>		
	<i>28 Cable Routing</i>		



WELCOME TO THE FAMILY

AT INTENSE WE HAVE ONE GOAL - TO PROVIDE THE RIDE OF YOUR LIFE

Our team of designers, engineers and product experts are focused on one thing every day: your experience on the bike. We build bikes that are as thrilling to look at as they are to ride, and we build them for the select few of you who understand the difference and refuse to settle for anything else.

From the early days of INTENSE, when founder Jeff Steber worked alone in his garage, to today with our crew of talented people working in our Temecula, CA headquarters, INTENSE has been a brand built on passion by forward thinkers who love nothing more than to throw a leg over a sweet bike and head out for a rip. We're so glad you've joined us. Welcome to INTENSE, enjoy your experience.

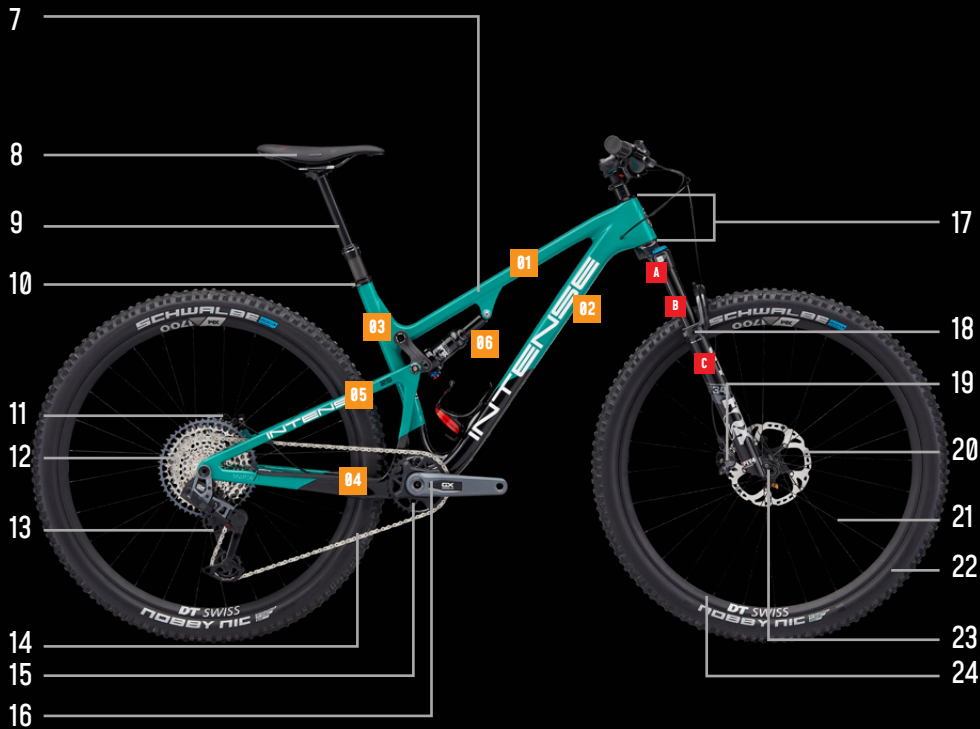
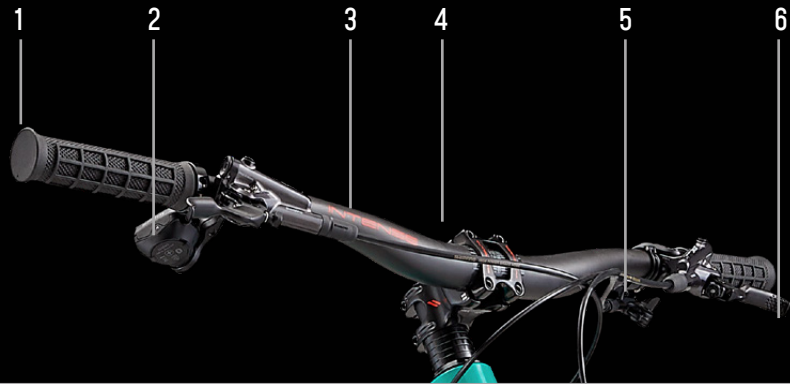

KNOW YOUR SNIPER T

**COMPONENT
BREAKDOWN**

- 1 Grips**
- 2 Shifter**
- 3 Handlebars**
- 4 Stem**
- 5 Dropper post lever**
- 6 Brake lever**
- 7 Frame**
 - 01 Toptube
 - 02 Downtube
 - 03 Seattube
 - 04 Chainstay
 - 05 Seatstay
 - 06 Rear shock
- 8 Saddle (seat)**
- 9 Dropper seatpost**
- 10 Seatpost clamp**
- 11 Rear brake**
- 12 Cassette**
- 13 Rear derailleur**
- 14 Chain**
- 15 Chainring**
- 16 Crankset**
- 17 Headset**
- 18 Suspension Fork**
 - A Fork crown
 - B Stanchion
 - C Lower leg
- 19 Front brake**
- 20 Rotor**
- 21 Spoke**
- 22 Tire**
- 23 Thru axle**
- 24 Rim**

Model:	INTENSE SNIPER T PRO
Model Year:	2024
Compatible Forks:	120mm Travel
Headtube/Headset:	Integrated IS41/28.6, IS52/40
Frame Seattube Dimensions:	ID 31.6mm (ID = Inside Diameter)
Bottom Bracket:	Press Fit 92
Recommended Max Tire Size:	2.4"
Brakes:	Direct Post Mount 160mm
Minimum Rotor Size:	160mm
Maximum Rotor Size:	203mm
Rear Hub:	148 x 12mm through axle BOOST
Rear Shock Eye-to-Eye:	165mm
Stroke:	45mm
Mounting Bushing Width Front:	20 x 8mm
Mounting Bushing Width Rear:	Trunnion



INTENSE SNIPER T **SET-UP GUIDE**

Your new INTENSE Sniper T is almost ready to go, you just need to do a few things to get your bike ready for its first ride. If you are setting up your bike from the box, the next few pages will show you how to assemble it. If you picked up your bike already set-up by a dealer then you can jump to page 30.

We have a series of in-depth and detailed videos on our website that go through the whole process of building and preparing your bike – including technical videos on suspension set-up, tuning your gears, and much more.

GO TO: [HTTPS://WWW.YOUTUBE.COM/@INTENSECYCLES1993](https://www.youtube.com/@intensecycles1993)



WE ARE HERE TO HELP!

If at any time you feel unsure about what you are doing then please contact us at INTENSE or seek the help of a professional mechanic at your local bike shop.

INTENSE +1 951.307.9211

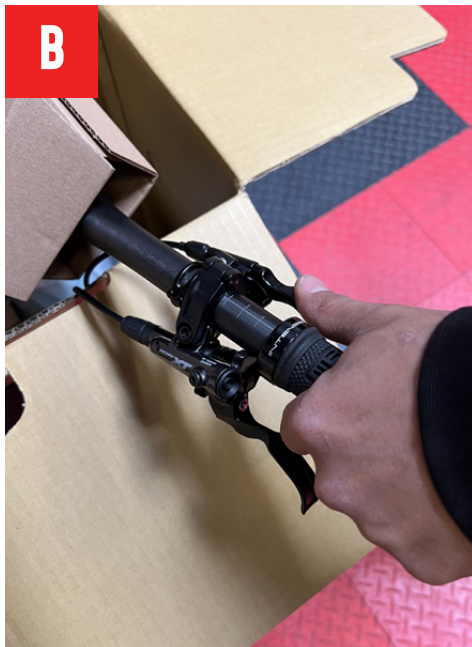

STEP 1

**REMOVE WHEELS
& PUT BIKE IN STAND**

When you first open your bike box you will find an accessory/tool box and the bike itself. Carefully locate the tool box and remove the wheels from the bike box **(A)** and put to one side.

While the bike is still in the box, take off the packaging around the handlebars and expose the dropper post lever on the left-hand side of the handlebar. Push dropper post lever **(B)**. This will raise the dropper post to its highest position, which will allow you to put the bike safely in a bike stand. Pull the bike out and place in bike stand. Only use the seatpost to clamp the bike to the stand **(C)**.



STEP 2

**INSTALL
HANDLEBARS**

Remove any packaging on the front of the bike, then spin the handlebar stem 180° so that the stem and forks are facing forward (A). Make sure that the forks are the correct way around – the front brake caliper should be on the left (non-drive) side of the bike, with the fork arch facing forward.

Using a 4mm Allen key remove the faceplate (B) of the stem and put the handlebars in place. Use the guidelines printed on the handlebars to help position them centrally and evenly. Check that the brake, gear and dropper post cables have a nice flow and are not kinked or twisted in any way.

Replace the faceplate of the stem and reinsert the bolts, firstly by hand and then with the 4mm Allen key (C). Gradually tighten the bolts, making sure that the bars are still positioned correctly and that the space between the faceplate and the main body of the stem is even all the way around.

When tightening the bolts follow this pattern to ensure even clamping: top left, bottom right, bottom left, top right. Finish off using the torque wrench to 6Nm (D).

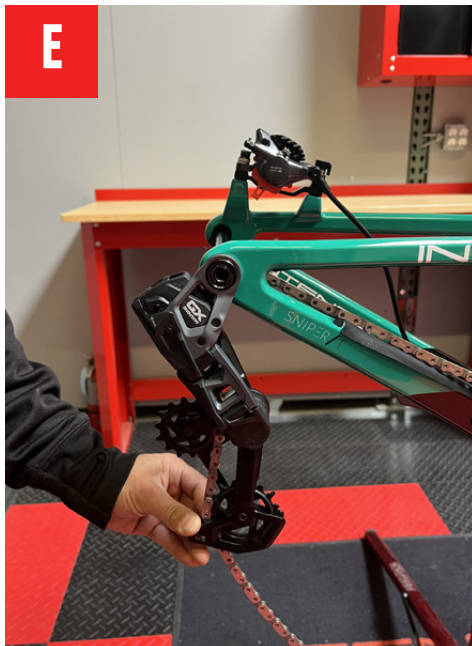

STEP 3

INSTALL REAR DERAILLEUR

Move to the rear of the bike and cut off any zip-ties or packaging from the rear derailleur and chain (A).

Locate the derailleur battery from the SRAM AXS Power Pack Box, remove the red cover from the battery (B). Return to the bike derailleur and open battery lock lever and remove the red dust cover (C). Once the dust cover is removed install the battery (D). To ensure the battery is locked into place, press the lock lever up until you hear an audible click.

Holding the bottom of the derailleur cage pivot the derailleur toward the front of the bike (E). There will be some resistance from the spring, so be careful that it doesn't spring back into position.

When it won't go any further forward, and in a near vertical position, press the small button (F) with a padlock logo printed on it. This is the 'Cage Lock'. While holding the lock button, gently release the derailleur cage. The derailleur should now be locked in position, which will make it easier for you to fit the rear wheel.



STEP 4

**INSTALL
REAR WHEEL**

Take out the rear brake pad spacer (A). Once removed be careful not to squeeze the brake lever until the rear wheel is in position. The rear axle features an integrated pull-out lever, unscrew using the lever and remove the rear axle. Simply pull this out, unscrew and remove the rear axle (B).

Remove any packaging left on the rear wheel, including the large black plastic rotor guards (C). Be careful that the metal wheel spacers don't get pulled off by accident. If they do just press them back into position. Do not touch the brake rotors with your hands or gloves, as any small amount of grease may contaminate them.

Position the chain on the smallest cog of the cassette (D). The derailleur will already be in its 'locked' position making it easier for you to install the wheel (E). Carefully line up the cassette and rotor with the rear brake making sure that it slides inside the caliper body between the brake pads (F). The hub spacers slide into the slots on the frame dropouts.





G

STEP 4 CONTINUED...

Once everything is lined up and in position, reinsert the axle and tighten using the integrated lever on the non-drive side (left), turning clockwise until tight (G). Reinstall the lever within the axle by pushing it firmly back in place. Then with a 5mm Allen key on the drive side of the bike tighten the axle to 11Nm (H).

You can now take the lock off your SRAM rear derailleur (I). To do this, gently push the derailleur cage forward a little, the lock will automatically release, slowly let the derailleur arm move backward into position.



H



I

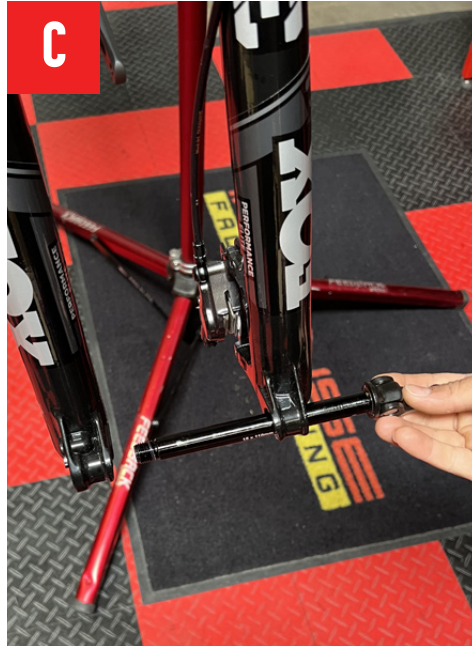

STEP 5

**INSTALL
FRONT WHEEL**

Remove all packaging from the front wheel **(A)** making sure the hub end caps are still in the correct place and that they haven't been pulled off by accident. If they do come off, just press them back into position. Then remove the brake pad spacer **(B)**. At this stage be careful not to pull the front brake lever until the wheel has been installed. Do not touch the brake rotors with your hands or gloves as this may contaminate them.

Flip the quick release lever on the fork axle and unscrew it **(C)**. Position the wheel so that the rotor fits into the brake caliper body and that the hub body slots into the grooves on the fork **(D)**. When everything is in the correct place reinsert the front wheel axle **(E)**, tighten, then clamp it tight using the quick release lever. There should be some resistance when the lever is flipped into the vertical position **(F)**. Note: loosening/ tightening the pinch bolt is not necessary for axle removal or installation.



STEP 6

**INSTALL
PEDALS**

(A) Pedals are somewhat of a personal choice – some people prefer flat pedals, others clipless, and then of course there are all the different brands and designs. So please take note, your bike does not come supplied with pedals, so that you can choose your own.

Note: Bicycles have specific left and right pedals and the left-hand side pedal has an opposite thread on it and this means that it tightens up in a counterclockwise direction.



STEP 7

**WIRELESS GEARING SET UP
& SHIFTING INSPECTION**

The Sniper T PRO comes supplied with SRAM's AXS wireless shifter and rear derailleur. Your wireless system should come paired, if it is not you can perform the following steps. In order to pair the shifter and derailleur so that they are 'talking' to each other. Press and hold the button on the derailleur until it starts blinking, then release the button. Your derailleur is now in pairing mode. Press and hold the button on the shifter/controller until it flashes rapidly a few times, then release. Go back to the derailleur and press the button once and release. The pairing process is now complete. SRAM's AXS App is a great tool that lets you view your shifting data, battery charge level, etc., and it also allows you to customize your controllers and their shifting functions. If you are having any issues with your gears or for more information please visit the SRAM website sram.com

Check that the gears are shifting correctly by turning the cranks and shifting through the gears. (B) The bikes are setup and tuned before packaging, however minor adjustments may be required. Please check out our tech video on drivetrain adjustments.



STEP 8

**ADJUST HEADSET
& HANDLEBARS**

Your bike's headset comes 'pre-loaded' from our factory but it is good practice to check it. If it feels a little loose then undo the stem clamping bolts slightly using a 4mm Allen key (A). Then gently tighten the top cap bolt 2-4Nm using a 5mm Allen key (B). Retighten the stem clamp bolts and check the headset again. If the bars won't turn smoothly, it is too tight, so repeat the process but this time slacken the top cap bolt off a little, or if it is too loose, continue to tighten.

Once you are happy with your headset adjustment you need to make sure that your stem and handlebars are straight (C). If the bars are not straight, loosen the two pinch bolts using a 4mm Allen key, take your bike out of the stand, straddle it, then look down and align your handlebars with your front wheel. Take your time to get it right, and when you are happy tighten the two stem bolts to 5-7Nm using a 4mm Allen key (D). Torque values are listed on the stem for reference.



STEP 9

ADJUST SADDLE HEIGHT

Set the height of your saddle (seat) with your seatpost in its fully extended position. Using a 4mm Allen key loosen the seatpost clamp and adjust the seatpost to the correct height. A good base measurement is to stand next to your bike in your riding shoes, putting your hand against the top of your hip bone (A). The palm of your hand should be level with the top of the saddle. Adjust as appropriate, then tighten the seat clamp to 4Nm. Do not overtighten this bolt as it may affect the performance of the seatpost. Note: You may have to slightly readjust the saddle height once you have set up your suspension correctly.

STEP 10

INSTALL BOTTLE CAGE

Your bike comes supplied with a water bottle cage. Undo the two 3mm bolts on the down tube of your bike and fit the cage (B). Tighten to 3Nm.

STEP 11

CHECK TIRE PRESSURE

The ideal tire pressure setting is determined by four main factors: rider weight, type of terrain, design/ construction of tire and the desired balance of comfort and traction. The pressures here are a suggested starting point and can typically range +/- 5psi. Front: 26psi, Rear 29psi. It is always a good idea to inspect your tires for tears and punctures before and after every ride.



IMPORTANT NOTE:

SNIPER T CABLE ROUTING

After assembly, it is important to ensure the brake line is positioned 38mm (1.5") away from the bottom surface of the downtube. This allows enough slack in the cable so they do not come under tension when the suspension compresses.

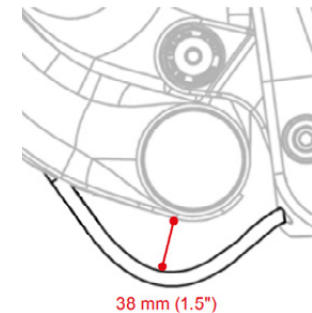

If there is too much slack push the cable up into the downtube gently, do not push the cable into the rear triangle as it will cause the cable to rub against your spokes. If there is not enough slack gently pull the cable out of the downtube to 38mm (1.5"). After adjusting your cables be sure to check the cable clearance between your brake cable and wheel.

STEP 12
FRONT SUSPENSION SETUP SNIPER T PRO

The Sniper T Pro uses FOX air sprung suspension front and rear, so first you need to set the air pressure. Look at the air pressure chart below to calculate the air pressure you require. Remember to calculate your weight when you are in full riding gear. You are looking for approximately 20% sag, so for the 120mm (4.7") fork that comes on the Sniper T Pro that measurement should be around 24mm (1"). Adjust the pressure in your forks until you reach the correct sag.

FORK: FOX PERFORMANCE ELITE 34 FLOAT, FIT4, 120MM
SUGGESTED STARTING POINTS FOR SETTING UP YOUR FORK

RIDER WEIGHT (LBS/KGS)	AIR PRESSURE (PSI)	REBOUND DIAL NO. OF CLICKS	OPEN MODE ADJUST
120-130 / 54-59	58	12	18
130-140 / 59-64	63	11	18
140-150 / 64-68	68	10	16
150-160 / 68-73	72	9	16
160-170 / 73-77	77	8	14
170-180 / 77-82	82	7	12
180-190 / 82-86	86	6	12
190-200 / 86-91	91	6	10
200-210 / 91-95	96	5	10
210-220 / 95-100	100	4	8
220-230 / 100-104	105	3	6
230-240 / 104-109	110	2	6
240-250 / 109-113	114	1	5



ADJUSTING FIT4 COMPRESSION DAMPING

3-Position Micro Adjust: The 3-position lever is useful to make on-the-fly adjustments to control fork performance under significant change in terrain, and is intended to be adjusted throughout the ride.

Use the OPEN mode during rough descending, the MEDIUM mode for undulating terrain, and the FIRM mode for smooth climbing.



REBOUND

Open
 (counterclockwise)
 Least amount of rebound damping. Fork rebounds fastest.

Closed
 (clockwise)
 Most amount of rebound damping. Fork rebounds slowest.

The rebound adjuster for the fork is a red dial located on the bottom of the right fork leg. Rebound controls how fast the fork extends after compressing. The rebound adjustment is dependent on the air pressure setting. For example, higher air pressures require more rebound damping. Use your air pressure to find your rebound setting. Turn your rebound knob to the closed position (full clockwise) until it stops. Then back it out (counterclockwise) to the number of clicks shown in the table below.

Adjust rebound until (when tested) the fork returns quickly but does not top out. Top out is felt when a fork fully extends too quickly and comes to an abrupt stop when it reaches full extension (you will hear a small noise). Top out should be avoided through proper rebound setting.

STEP 13

REAR SUSPENSION SETUP SNIPER T PRO

Use the chart below to calculate the air pressure required for your weight. Sag for the rear shock should be 30%. The measurement should be approximately 13.5mm (0.5") between the black O-ring and the shock body.

SHOCK: FOX FLOAT DPS PERFORMANCE ELITE, 165MM X 45MM
SUGGESTED STARTING POINTS FOR SETTING UP YOUR SHOCK

RIDER WEIGHT (LBS/KGS)	AIR PRESSURE (PSI)	REBOUND (CLICKS OUT FROM FULLY CLOSED)
100LBS / 45KGS	105	11
110LBS / 50KGS	115	10
120LBS / 54KGS	130	9
130LBS / 59KGS	140	9
140LBS / 63.5KGS	150	9
150LBS / 68KGS	160	8
160LBS / 73KGS	170	8
170LBS / 77KGS	180	8
180LBS / 82KGS	190	7
190LBS / 86KGS	200	7
200LBS / 91KGS	210	7
210LBS / 95KGS	220	6
220LBS / 100KGS	230	6
230LBS / 104KGS	240	5
240LBS / 109KGS	250	5
250LBS / 113KGS	260	4



COMPRESSION ADJUSTMENTS

The 3-position lever is useful to make on-the-fly adjustments to control shock performance under significant changes in terrain, and is intended to be adjusted throughout the ride. Use the Open mode during rough descending, the Medium mode for steep climbs where traction is paramount, and the Firm mode for climbing on smooth terrain or hard surfaces.



REBOUND

Open
 (counterclockwise)
 Least amount of rebound damping. The shock rebounds fastest.

Closed
 (clockwise)
 Most amount of rebound damping. The shock rebounds slowest.



Proper set up and tuning can vary from shock to shock. Please consult the FOX manual included with your bike for complete information about set up, tuning and general maintenance or visit ridefox.com

STEP 14

FINAL CHECK

You are almost ready to go riding. Now is a good time to check over your bike to make sure that everything looks correct – all packaging is removed, bolts are tightened to the correct torques, etc. Most importantly you need to check that both the front and rear brakes are working properly. After your first ride check over your bike again, making sure that all bolts are secure. After that follow the Maintenance Schedule on page 36.

As you get to know your bike you may want to make some small personal adjustments – rolling your bars forward or backward a little, position your brake levers at a slightly different angle, adjust your suspension, experiment with tire pressure or slide your saddle backward or forward. This is all perfectly normal, just making small tweaks here and there to really personalize your bike so that it is right for you.

COMPONENT SPEC NOTE

The Sniper T is designed around the use of a single chain ring only. Use of a double or triple ringset will not allow proper clearance of the frame.

WARNING

Not intended for use with forks larger than 120mm of travel.

SNIPER T GEOMETRY CHART

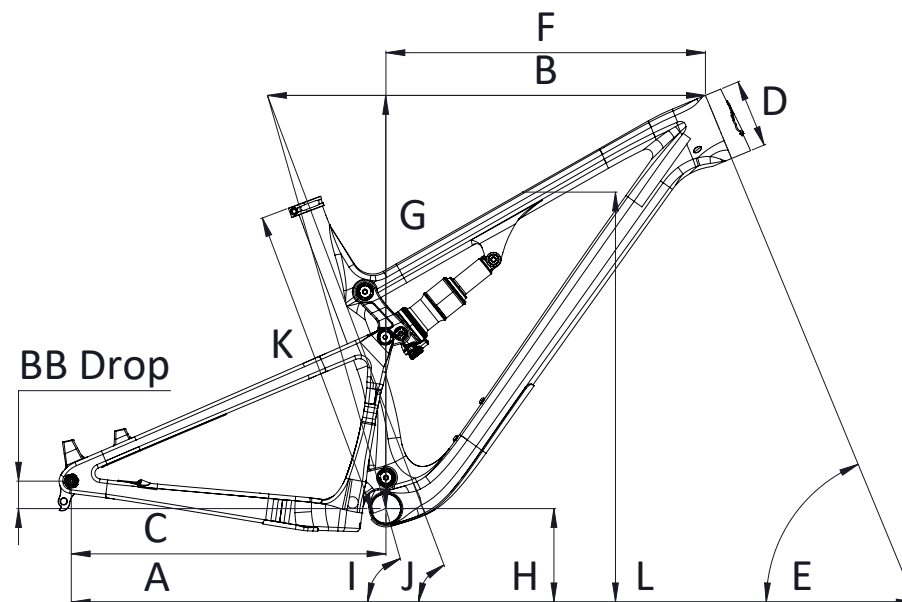

SIZE	SMALL	MEDIUM	LARGE	EXTRA LARGE
WHEELBASE (A)	1145 MM / 45"	1171 MM / 46"	1198 MM / 47"	1224 MM / 48"
TOPTUBE LENGTH (B)	589 MM / 23.2"	615 MM / 24.2"	640 MM / 25.2"	665 MM / 26.2"
CHAINSTAY LENGTH (C)	439 MM / 17.3"	439 MM / 17.3"	439 MM / 17.3"	439 MM / 17.3"
HEADTUBE LENGTH (D)	90 MM / 3.5"	95 MM / 3.7"	105 MM / 4.13"	115 MM / 4.5"
HEADTUBE ANGLE (E)	66.2°	66.2°	66.26°	66.29°
REACH (F)	408 MM / 16"	432 MM / 17"	455 MM / 17.9"	477 MM / 18.8"
STACK (G)	580 MM / 22.8"	585 MM / 23"	594 MM / 23.4"	603.5 MM / 23.8"
BB HEIGHT (H)	340 MM / 13.4"	340 MM / 13.4"	340 MM / 13.4"	339 MM / 13.4"
BB DROP	28.2 MM / 1.11"	28.5 MM / 1.12"	28.7 MM / 1.13"	28.9 MM / 1.14"
SEATTUBE ANGLE (EFFECTIVE) (I)	72.6°	72.6°	72.65°	72.68°
SEATTUBE ANGLE (ACTUAL) (J)	68.1°	68.1°	68.16°	68.19°
SEATTUBE LENGTH (K)	406 MM / 16"	437 MM / 17.2"	488 MM / 19.2"	538 MM / 21.2"
STANDOVER HEIGHT (L)	767 MM / 30.2"	784 MM / 30.9"	789 MM / 31"	794 MM / 31.25"

BIKE CARE
**MAINTENANCE
 SCHEDULE**

You have purchased a high-performance bicycle which requires a certain level of service and maintenance to sustain the level of performance your frame was designed around. Proper care will also ensure the bike is safe to ride at all levels. It is important to read and understand the carbon care information as well as follow the maintenance schedule and inspect your bicycle before each ride. These will not only help to limit or avoid costly repairs but will also help to avoid injury due to service neglect and component failure.

	ACTION	EVERY RIDE	500	2000	4000
			MILES OR 1 MTH	MILES OR 6 MTHS	MILES OR 1 YR
TIRES	CHECK AIR PRESSURE, INSPECT TREAD AND SIDEWALLS FOR TEARS AND PUNCTURES	X			
CHAIN	BRUSH OFF AND LUBRICATE	X			
BRAKES	SQUEEZE BRAKES AND CONFIRM FUNCTION	X			
GENERAL	CLEAN COMPLETE BIKE OF MUD AND DEBRIS	X			
HEADSET	CHECK ADJUSTMENT		X		
BOX LINK	ADD GREASE THRU ZERK FITTINGS		X		
FRAME PIVOTS	CHECK TORQUES		X		
SPOKES	INSPECT FOR DAMAGE, CHECK TENSION		X		
SHOCK & FORK	CHECK AIR PRESSURE, INSPECT FOR LEAKS		X		
DERAILLEUR	CHECK BOLT AND INSPECT JOCKEY WHEELS			X	
SEATPOST	CLEAN AND REGREASE INTERFACE WITH FRAME			X	
FRAME PIVOTS	REMOVE PIVOT BOLTS, CHECK BEARINGS FOR PITTING AND WEAR			X	
HEADSET	DISASSEMBLE STEM, HEADSET AND FORK. CHECK BEARINGS FOR PITTING AND WEAR			X	
HUBS	PULL WHEELS OFF, CHECK HUB BEARINGS FOR PITTING AND WEAR			X	
BOTTOM BRACKET (BB)	REMOVE CRANKARMS AND CHECK BB BEARINGS FOR PITTING AND WEAR			X	
BRAKES	REPLACE BRAKE PADS			X	
CHAIN	INSPECT FOR DAMAGE AND CHECK FOR STRETCHING			X	
GENERAL	COMPLETE TUNE-UP				X

MAINTENANCE
**CARBON
 CARE**

INTENSE employs advanced composite techniques and material in our frames which do require a certain level of care and maintenance to ensure a safe experience at the high level of performance each frame is designed around. Not following these guidelines will decrease the level of performance and possibly cause injury or death.

- Use a soft cloth with warm soapy water to clean the carbon surfaces. Do not use high pressure washers, abrasive cloths or cleaner.
- Be sure all frame surfaces in contact with cables are protected. Cable housing rubbing on carbon can wear over time.
- Be sure brake levers, handlebar ends and the fork crown do not contact the frame at full rotation.
- Never clamp any part of a carbon frame in a bike stand or car rack.
- Always inspect your frame if you experience any chain suck.
- Always inspect your frame in full after a crash to be sure there is no damage. Look for cracks, dents or loose fibers. If you discover damage in any degree it's best to have your frame inspected by a qualified INTENSE, LLC dealer. Any direct impact to the frame can cause serious structural damage.
- Use high-grade waterproof grease on seatpost, BB and headset bearing contact areas with the carbon.
- Never ream or face a carbon frame.
- Be sure to follow all recommended torque settings.
- Use only genuine replacement parts for safety-critical components.

SNIPER T PRO
PARTS LISTING

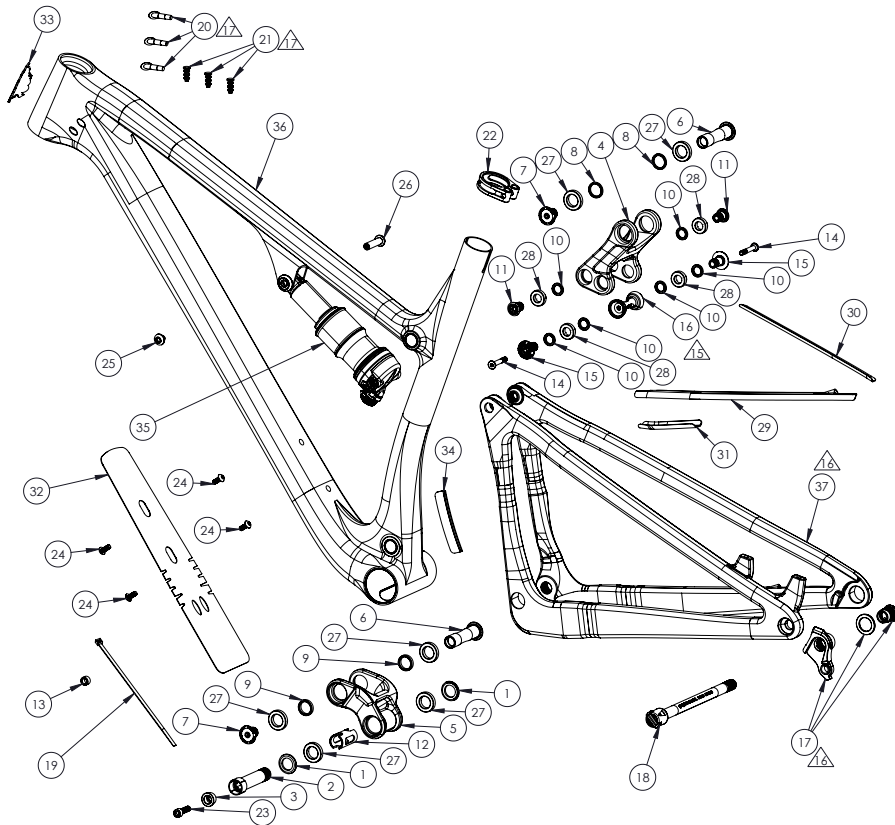

ITEM	PART No.	DESCRIPTION	QTY.	TORQUE SPEC.
1	130765	Bearing Cap 24mm OD Cap Bearing Blk	2	N/A
2	130791	Bolt Main Pivot Bolt Main Pivot 1.5t Expander Blk	1	7 Nm / 60 in-lbs
3	130807	Cone Adjuster Spacer Cone Adjuster Blk, 8.3 mm Height	1	N/A
4	130823	Injection Top Link Link Top Sniper Injection Blk	1	N/A
5	130825	Forged Lower Link Link Box Forged BLK Sniper	1	N/A
6	130828	Axle Upper Axle Pivot	2	16 Nm / 140 in-lbs
7	130829	Bolt Shoulder Bolt Shoulder	2	16 Nm / 140 in-lbs
8	130830	Spacer Upper Axle 19 mm OD 15 mm ID 2.5 mm	2	N/A
9	130831	Spacer Lower Link Lower Axle 19mm OD x 15mm ID x 4mm	2	N/A
10	130832	Spacer RT/Top Link Upper Axle 15mm OD x 10mm ID x 2.5mm	6	N/A
11	130833	Trunnion Bolt Bolt Shoulder Trunnion Rear Shock	2	16 Nm / 140 in-lbs
12	130845	Crush Tube Crush Tube Sniper Lower Link	1	N/A
13	130856	Cable Spacer Cable Spacer, Lower Cable Guide, Blk	1	N/A
14	130875	Low Profile M5 X 32 M5 x 32, T25 Torx, Cross Brace	2	4 Nm / 36 in-lbs
15	130877	Clevis Bolt Bolt Shoulder RT Clevis	2	16 Nm / 140 in-lbs
16	130884	Cross Brace Offset Cross Brace M5 X 0.8 Thread SID	1	N/A
17	130897	Derailleur Hanger UDH Universal Derailleur Hanger, GW	1	25 Nm / 221 in-lb
18	130899	Rear Axle M12 x P1.0 x 172mm(148 x 12mm) QR491, Wheel Axle Kit, TW	1	11 Nm / 100 in-lbs
19	140053	Zip Tie Zip Tie, Lower Cable Guide	1	N/A
20	140096	AXR01 Grommet Plug YF_AXR01 Grommet Plug for AXS Upgrade 3	3	N/A
21	140097	Grommet Plug Jagwire_CCN081RB Grommet Plug for AXS	3	N/A
22	340343	Sniper Seat Clamp Sniper Seat Clamp	1	4 Nm / 35.5 in-lbs
23	410009	SHCS M6 x 22 SHCS, Socket Head, M6 x 22	1	14 Nm / 125 in-lbs
24	410010	BHCS M5 X 12 BHCS, Button Head, M5 X 12	4	2 Nm / 18 in-lbs
25	410056	Shock Shoulder Bolt Left Shock Bolt C29, M6 Thread, Steel	1	7 Nm / 60 in-lbs
26	410060	Shock Shoulder Bolt Right 8mm OD x 31mm Long Female Steel	1	7 Nm / 60 in-lbs
27	430008	Bearing 6802 Bearing 6802 LLU MAX	6	N/A
28	430011	Bearing 6800 Bearing 6800 LLU MAX	4	N/A
29	500294	Guard Flak CS Flak Guard Sniper Chainstay Top	1	N/A
30	500295	Guard Flak Ststy Flak Guard Sniper Seatstay	1	N/A
31	500296	Guard Flak CS Flak Guard Sniper Chainstay Bottom	1	N/A
32	500297	Guard Flak DT Flak Guard Sniper Downtube	1	N/A
33	500335	Head Badge Head Badge Flame Logo	1	N/A
34	500510	Guard Flack Strut Flack Guard Sniper Trail Driveside Strut	1	N/A
35		Rear Shock Fox Float DPS 165 x 45	1	N/A
36		Front Triangle Sniper T Front Triangle	1	N/A
37		Rear Triangle Sniper T Rear Triangle: UDH T-Type	1	N/A

SNIPER T PRO
PARTS KITS

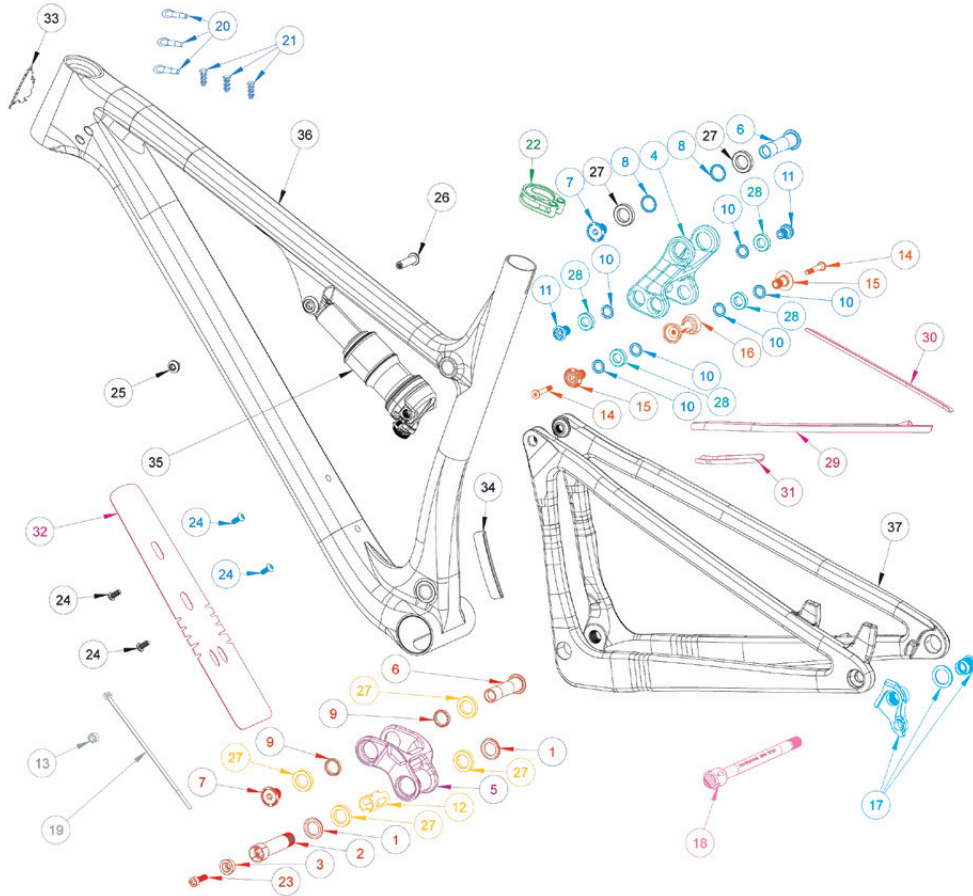

- IT150125 AXLE KIT REAR CNC 148X12 BOOST WITH HIDDEN LEVER**
 130899 Axle Rear 148x12mm Boost Blk with Hidden Lever
- IT150002 BEARING REBUILD KIT LOWER SNIPER T**
 130845 Crush Tube Sniper Lower Link
 430008 Bearing 6802-2RS-MAX
- IT150036 LINK KIT UPPER CROSSBRACE SNIPER T**
 130875 SS Sniper Crossbrace Fastener Low Profile M5x32 T25 Torx
 130877 Bolt Shoulder RT Clevis Sniper Blk
 130884 Crossbrace M5x0.8 Sniper Rear
- IT150001 FRAME PROTECTION KIT FLAK GUARD SNIPER T SM/MD**
 500294TW Flak Guard Sniper Chainstay Top
 500295TW Flak Guard Sniper Seatstay
 500296TW Flak Guard Sniper Chainstay Bottom
 500297-1 Flak Guard Sniper Downtube
- IT150127 FRAME PROTECTION KIT FLAK GUARD SNIPER T LG/XL**
 500294 Flak Guard Sniper Chainstay Top
 500295 Flak Guard Sniper Seatstay
 500296 Flak Guard Sniper Chainstay Bottom
 500297 Flak Guard Sniper Downtube
- IT150141 UNIVERSAL DERAILLEUR HANGER KIT**
 130897 UDH Universal Derailleur Hanger
- IT150007 LINK KIT LOWER HARDWARE STAINLESS SNIPER T**
 130765 Cap Bearing 24mm OD Blk
 130791 Bolt Main Pivot 1.5t Expander Blk TW
 130807 Spacer Cone Adjuster 8.3mm (Short) Blk TW
 130828 Axle Pivot Sniper
 130829 Bolt Shoulder Sniper
 130831 Spacer Lower Axle 19OD x 15ID x 4mm Sniper
 140038 Plug Trim 15mm YF
 410009 Bolt SHCS M6x22 Titanium
- IT340243 LINK KIT LOWER COMPLETE FORGED ALLOY SNIPER T**
 130825 B Link Kit Lower Forged Alloy Sniper with Bearings
- IT340233 LINK KIT UPPER COMPLETE CARBON SNIPER T**
 130823 B Upper Link Carbon Sniper Blk with Bearings

SNIPER T PRO
PARTS KITS CONTINUED...

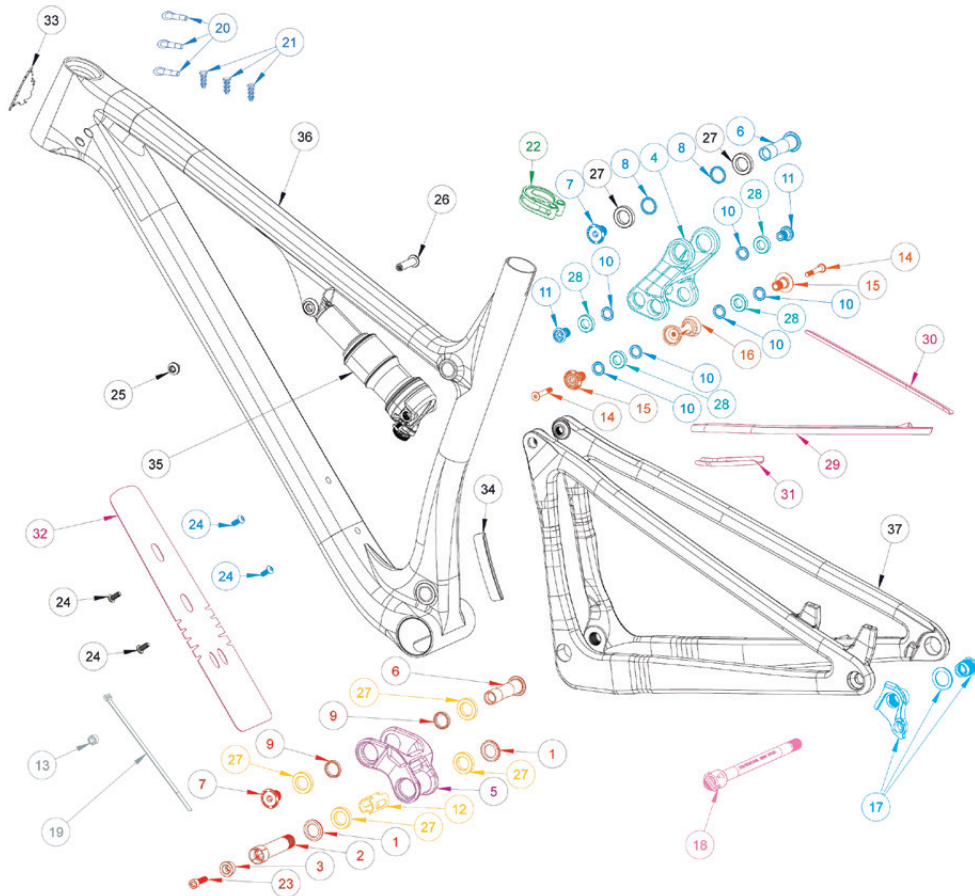

22

IT340343 SEAT COLLAR BOLTED 36.1 SNIPER T
 340343 Sniper Seat Clamp

6

IT150004 HARDWARE KIT UPPER

- 130828 Axle Pivot Sniper
- 130829 Bolt Shoulder Sniper
- 130830 Spacer Upper Axle Sniper 19mm OD x 15mm ID x 2.5mm
- 130832 Spacer Upper Axle 15mm OD x 10mm ID x 2.5mm Sniper
- 130833 Bolt Shoulder Trunnion Rear Shock Sniper
- 130877 Shoulder Bolt RT Clevis Sniper
- 410066 Shock Bolt Sniper M6 Thread 7075-T6
- 410067 Shock Bolt 8mm OD x 31mm Long Female 7075-T6

7

8

10

11

15

25

26

21

22

IT150238 GROMMET PLUG KIT WIRELESS

- 140096 YF_AXR01 Grommet Plug for AXS Upgrade
- 140097 Jagwire_CCN081RB Grommet Plug for AXS Upgrade

13

19

IT150240 CABLE GUIDE KIT SNIPER T

- 130856 Cable Spacer
- 140053 Zip Tie Lower Cable Guide

24

IT340191 WATER BOTTLE CAGE BOLT KIT (2 BOLTS)

- 410010 BHCS Button Head M5x12

TORQUE SPECIFICATIONS

Achieving correct torque is vital to ensuring the proper performance and function of the SNIPER T frame. Failure to do so could result in suboptimal performance of your frame as well as premature wear and tear of individual parts. In addition to this chart, torque values are laser etched onto corresponding hardware for your reference.

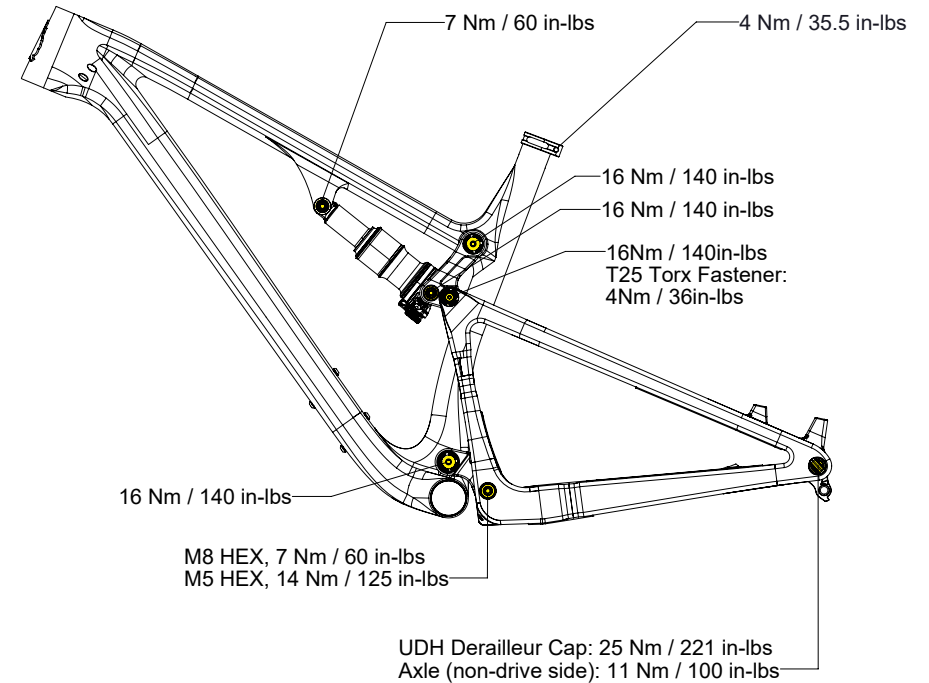

Torque Range to Note: Various Seatposts could require different torque values to secure in frame and also maintain dropper post function. Refer to dropper seatpost manuals/websites when needed.

INTENSE



2024//
SNIPER T PRO

MANUAL