



INTENSE

USER MANUAL // PRIMER 29

WELCOME TO THE FAMILY

*AT INTENSE, WE HAVE ONE GOAL -
TO PROVIDE THE RIDE OF YOUR LIFE //*

Our team of designers, engineers and product experts are focused on one thing every day: your experience on the bike. We build bikes that are as thrilling to look at as they are to ride, and we build them for the select few of you who understand the difference and refuse to settle for anything else. From the early days of Intense, when founder Jeff Steber worked alone in his garage to today, where a crew of talented people work in a Temecula, CA factory, Intense has been a brand built on passion by forward thinkers who, even today, love nothing more than to throw a leg over a sweet bike and head out for a rip. We're so glad you've joined us. Welcome to Intense, enjoy your experience.

THE PRIMER 29 //

Designed for the big wheel, trail enthusiast, the Primer 29 with the addition of New Flip Chip sports 140 mm / 5.5" or 137 mm / 5.4" of rear wheel travel on an extra wide, Boost 148 rear end. The carbon front and rear triangles provide an exceptionally stiff yet comfortable ride that is light and nimble. The bike is race ready and features internal cable routing, 160 mm post mounts and protective flak guards as standard amenities.



TABLE OF CONTENTS //

Introduction / Registration	2
Getting to Know Your Primer 29	4
Frame Features / Component Spec	4
Geometry	5
Exploded View and B.O.M.	6
Assembly	8
Frame Assembly	9
Torque Specifications	16
Setup	17
Seatpost	17
Setting the Sag	18
Shock Setup	19
Setting the Flip Chip	20
Maintenance	22
Carbon Care	22
Maintenance Schedule	23

REGISTER YOUR BIKE //

www.intensecycles.com/warranty-card/

TECHNICAL ASSISTANCE

techcenter@intensecycles.com

951-307-9211

GETTING TO KNOW YOUR PRIMER 29

COMPONENT SPEC //

- Fork: FOX 34 150 mm with 51 mm fork offset, 557 mm axle to crown
- Rear Shock: 210 x 50, 20 mm x 8 mm rear reducer and 20 mm x 6 mm front reducer
- Headset: Cane Creek, 40, Alloy Cartridge, ZS 44 Upper/ EC 49 Lower (www.canecreek.com)
- Bottom Bracket: Threaded 73 mm
- Rear axle: BOOST 148 x 12
- Brake mount: post mount for 160 mm rotor
- Crank Set: BOOST 148 (single ring only)
- Rear wheel: BOOST 148
- Seat post: 31.6 mm

COMPONENT SPEC NOTE

The Primer 29 is designed around the use of a single chain ring only. Use of a double or triple ring set will not allow proper clearance with the frame.

WARNING

Not intended for use with forks larger than 150 mm of travel.

FRAME FEATURES //

- Rear Travel, Low Setting of Flip Chip: 140 mm 5.5 inches with 210 x 50 stroke shock
- Rear Travel, Lower Setting of Flip Chip: 137 mm 5.4 inches with 210 x 50 stroke shock
- 29" Wheel size
- Integrated BOOST 148 x 12 dropouts
- Internal cable routing
- Internal seat tube cable routing for dropper posts
- Monocoque front triangle
- H2O bottle fitment
- FLK – GRD Downtube, Chainstay, Seatstay, and Seattube protection
- Tapered head tube
- Max bearings and dedicated frame hardware

GEOMETRY //

GEOMETRY NOTE

Geometry taken at top out with 557 mm axle to crown length and 51 mm fork offset.

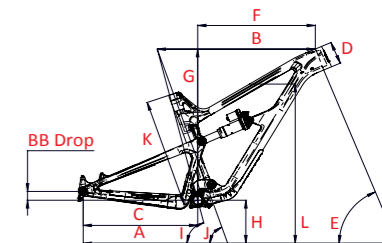

	FLIP CHIP SETTING:	SMALL		MEDIUM		LARGE		X LARGE	
		LOW	LOWER	LOW	LOWER	LOW	LOWER	LOW	LOWER
A	Wheel Base:	1167.9 mm / 46"	1168.9 mm / 46"	1198 mm / 47.2"	1199 mm / 47.2"	1226.9 mm / 48.3"	1227.82 mm / 48.3"	1264.9 mm / 49.8"	1265.8 mm / 49.83"
B	Top Tube Length:	577 mm / 22.7"	579.5 mm / 22.8"	607.4 mm / 23.9"	609.6 mm / 24.0"	635.6 mm / 25"	637.9 mm / 25.1"	672 mm / 26.5"	674.3 mm / 26.55"
C	Chain Stay Length:	440 mm / 17.3"	441.5 mm / 17.4"	440 mm / 17.3"	441.5 mm / 17.4"	440 mm / 17.3"	441.5 mm / 17.4"	440 mm / 17.3"	441.5 mm / 17.4"
D	Head Tube Length:	90 mm / 3.54"	90 mm / 3.54"	90 mm / 3.54"	90 mm / 3.54"	100 mm / 3.94"	100 mm / 3.94"	120 mm / 4.7"	120 mm / 4.7"
E	Head Tube Angle:	65.9°	65.3°	65.9°	65.3°	65.9°	65.3°	65.9°	65.3°
F	Reach:	420 mm / 16.5"	414 mm / 16.3"	450 mm / 17.72"	444 mm / 17.48"	475 mm / 18.7"	469 mm / 18.46"	505 mm / 19.9"	499 mm / 19.64"
G	Stack:	610.9 mm / 24"	615 mm / 24.2"	611 mm / 24"	615.4 mm / 24.23"	620.4 mm / 24.42"	624.9 mm / 24.6"	638.9 mm / 25.2"	643.5 mm / 25.3"
H	BB Height:	345 mm / 13.57"	337 mm / 13.3"	345 mm / 13.57"	337 mm / 13.3"	345 mm / 13.57"	337 mm / 13.3"	345 mm / 13.57"	337 mm / 13.3"
	BB Drop	30.3 mm / 1.2"	37.7 mm / 1.48"	30.4 mm / 1.2"	37.9 mm / 1.49"	30.52 mm / 1.2"	38.1 mm / 1.5"	30.66 mm / 1.21"	38.4 mm / 1.5"
I	Seat Tube Angle (Effective):	75°	74.3°	75°	74.4°	75°	74.4°	75°	74.2°
J	Seat Tube Angle (Actual):	70.3°	69.7°	70.3°	69.7°	70.3°	69.7°	70.3°	69.7°
K	Seat Tube Length:	408.4 mm / 16.08"	408.4 mm / 16.08"	430.8 mm / 16.96"	430.8 mm / 16.96"	451 mm / 17.8"	451 mm / 17.8"	475.5 mm / 18.7"	475.5 mm / 18.7"
L	Standover Height:	813.3 mm / 32"	807.6 mm / 31.8"	812.6 mm / 32"	807 mm / 31.8"	817 mm / 32.16"	811 mm / 31.9"	826 mm / 32.5"	820 mm / 32.3"

EXPLODED VIEW AND B.O.M. //

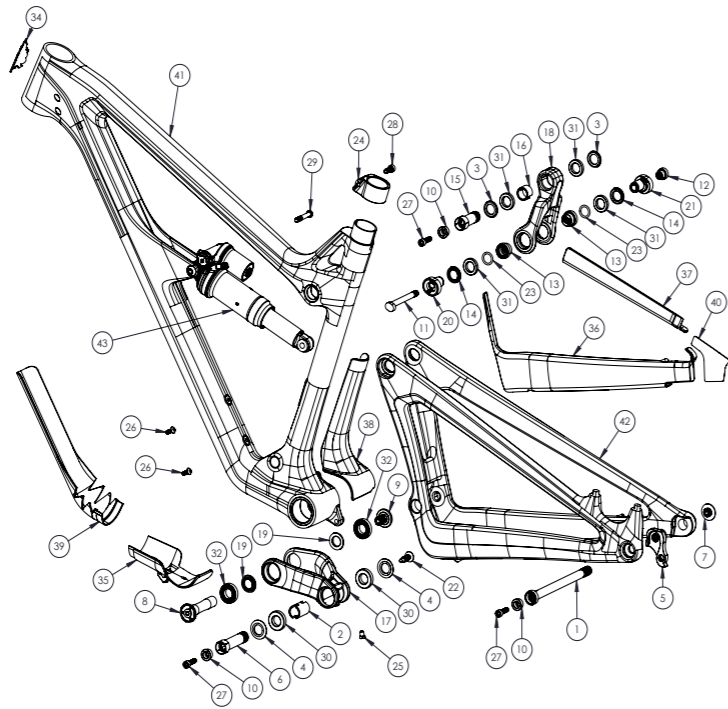

ITEM NO.	ITEM	PART NUMBER	DESCRIPTION	QTY.	TORQUE SPEC.
1	Rear Axle	130757	Axle Rear 148 mm x 12 mm Boost	1	11 Nm / 100 in-lbs
2	Bearing Spacer	130758	Lower Link Bearing Spacer (Rear)	1	N/A
3	Bearing Cap	130765	Upper Link Bearing Cap, 24 mm (Upper)	2	N/A

ITEM NO.	ITEM	PART NUMBER	DESCRIPTION	QTY.	TORQUE SPEC.
4	Bearing Cap	130778	Lower Link Bearing Cap, 28 mm (Rear)	2	N/A
5	Hanger	130790	Derailleur Hanger, Forged	1	N/A
6	Pivot Bolt	130791	Lower Link Pivot Bolt, 1.5T (Rear)	1	7 Nm / 60 in-lbs

ITEM NO.	ITEM	PART NUMBER	DESCRIPTION	QTY.	TORQUE SPEC.
7	Hanger Bolt	130798	Derailleur Hanger Bolt	1	11 Nm / 100 in-lbs
8	Pivot Axle	130800	Lower Link Pivot Axle (Front)	1	20 Nm / 175 in-lbs
9	Pivot Bolt	130806	Lower Link Pivot Bolt (Front)	1	20 Nm / 175 in-lbs
10	Cone Adjuster	130807	Cone Adjuster, 8.3 mm Height	3	N/A
11	Shock Bolt, Left	130813	D-Lock Bolt	1	16 Nm / 140 in-lbs
12	Shock Nut	130814	Shock Nut	1	16 Nm / 140 in-lbs
13	Bearing Spacer	130821	Upper Link Bearing Spacer w/ O-Ring (Lower)	2	N/A
14	Bearing Spacer	130835	Upper Link Bearing Spacer (Lower)	2	N/A
15	Pivot Bolt	130842	Upper Link Pivot Bolt (Upper)	1	7 Nm / 60 in-lbs
16	Bearing Spacer	130847	Upper Link Bearing Spacer (Upper)	1	N/A
17	Lower Link	130858	Forged Aluminum Lower Link	1	N/A
18	Top Link	130859	Carbon Top Link	1	N/A
19	Bearing Spacer	130860	Lower Link Bearing Spacer (Upper)	2	N/A
20	Flip Chip	130865	D-Lock Reducer, Right	1	N/A
21	Flip Chip	130866	D-Lock Reducer, Left	1	N/A
22	Plug	140038	Lower Link Pivot Plug	1	N/A
23	O-Ring	140044	13.8 mm ID x 2.4 mm	2	N/A
24	Seat Clamp	340342	Bolt-On Seat Clamp	1	N/A
25	Zerk Fitting	401011	M6 x 1.0	1	5 Nm / 40 in-lbs

ITEM NO.	ITEM	PART NUMBER	DESCRIPTION	QTY.	TORQUE SPEC.
26	BHCS M5 x 12	410010	Water Bottle Bolt, Button Head, M5 x 12	2	2 Nm / 18 in-lbs
27	SHCS M6 x 22	410032	Cone Adjuster Bolt, Socket Head, M6 x 22	3	14 Nm / 125 in-lbs
28	SHCS M6 x 18	410048	Seat Clamp Bolt, Socket Head, M6 x 18	1	5 Nm / 45 in-lbs
29	SHCS M6 x 40	410050	Shock Bolt, Socket Head, M6 x 40 Titanium	1	7 Nm / 60 in-lbs
30	Bearing 7902	430007	15 x 28 x 7 2RS Max Angular Contact Bearing	2	N/A
31	Bearing 6802	430008	15 x 24 x 5 2RS Max Radial Bearing	4	N/A
32	Bearing 6902	430009	15 x 28 x 7 2RS Max Radial Bearing	2	N/A
33	Decal	500300	California Bear	1	N/A
34	Head Badge	500335	Head Badge Flame Logo	1	N/A
35	Flack Guard Down Tube	500501	Flack Guard Primer 29 Down Tube	1	N/A
36	Flack Guard Chain Stay	500502	Flack Guard Primer 29 Chain Stay	1	N/A
37	Flack Guard Seat Stay	500503	Flack Guard Primer 29 Seat Stay	1	N/A
38	Flack Guard Seat Tube	500504	Flack Guard Primer 29 Seat Tube	1	N/A
39	Flack Guard Down Tube Front	500508	Flack Guard Primer 29 Down Tube Front	1	N/A
40	Chain Stay Protector	500509	Clear Chain Stay Protector	1	N/A
41	Front Triangle		Carbon, 4 Sizes	1	N/A
42	Rear Triangle		Carbon, 1 Size	1	N/A
43	Rear Shock		210 mm x 50Mm	1	N/A

ASSEMBLY

PREFACE //

Service and maintenance on an Intense bicycle requires special tools, abilities and knowledge of working on bicycles. It is always recommended to use an authorized Intense dealer for service and maintenance. Always wear eye protection. It is critical to use the proper tools, loctite, grease and torque specs during assembly. Failure to follow these instructions may result in serious bodily injury or death..

TOOLS NEEDED

- High Grade, waterproof grease
- Blue Loctite® #243
- Anti seize
- 4 mm HEX wrench
- 5 mm HEX wrench x 2
- 6 mm HEX wrench
- 8 mm HEX wrench
- Torque wrench

PRO TIPS

- Be sure to apply a thin coat of grease to all pivot axles and rear axle. This will reduce the chances of corrosion due to moisture and prevent any possible creaks.
- After the first few rides and all the components are broken in and settled into place, go through and re-torque all pivot axles and fasteners. After this first adjustment, you will be ready to rip for the long haul.
- Use grease on any metal to carbon interface, including headset. Also use grease on metal to metal interface of threaded bb.



CONNECTING TOP LINK TO FRONT TRIANGLE //

A Holding top link (#130859) as oriented in the above picture, apply grease to the outside face of each of the top two bearings in the top link to hold the upper spacers (#130765) against the outside bearing race (Image #1).



B Match upper link to top tube pivot point, making sure that spacers do not fall out (Image #2).



C Using top link collet bolt (#130842), insert into non-drive side of frame and push through the top link then thread into the frame, taking care that the spacers do not fall out.

D Using an 8 mm HEX wrench torque to 7 Nm or 60 in/lbs (Image #3).



E Grease and insert adjuster cone (#130807) into top link collet bolt (#130842). Grease M6 x 22 mm bolt and install through adjuster cone into top link collet bolt (Image #4). Torque M6 x 22 mm (#410032) to 14 Nm or 125 in/lbs.



CONNECTING THE LOWER LINK TO FRONT TRIANGLE //

A Apply grease to the two pivot axle spacers (#130860) to hold spacers against the inside of the lower link bearing race (Image #5).

B Match link to front triangle and from non drive side, insert greased lower pivot axle (#130800) through the non-drive side of frame (Image #6).

C Use 5 mm HEX to install shoulder bolt (#130806), and tighten to 20 Nm or 175 in/lbs (Image #7/7a).

CONNECTING REAR TRIANGLE TO LOWER LINK //

A Apply grease to bearing face of lower link and hold bearing caps (#130778) with rounded ends facing outwards, then press two caps against the back bearings on lower link (#130858) (Image #8).

B Mate rear triangle with lower link and align pivot points with bearing caps (Image #9).

C With lower pivot points aligned, insert main pivot bolt (#130791), using an 8 mm HEX wrench torque to 7 Nm or 60 in/lbs (Image #10).

D Grease and insert adjuster cone (#130807) into head of main pivot bolt (#130791). Grease M6 x 22 mm bolt and install through adjuster cone into main pivot bolt (Image #11). Torque M6 x 22 mm (#410032) to 14 Nm or 125 in/lbs.

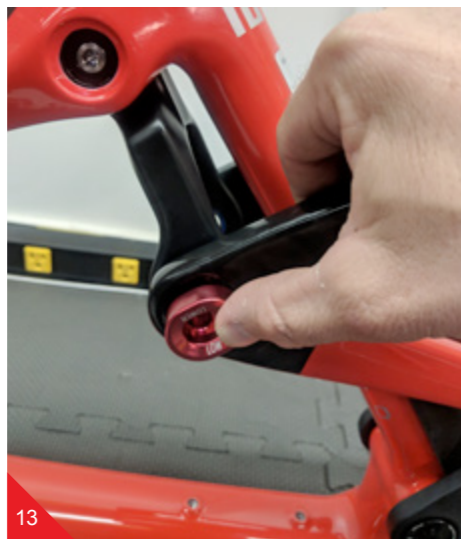
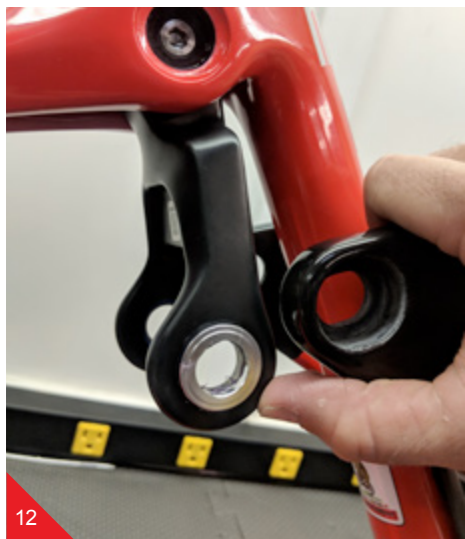

CONNECTING REAR TRIANGLE TO TOP LINK //

A Put a small dab of grease on the outside bearing race as well as on the contacting surface of the bearing caps (#130835). This will help hold the bearing caps in place during the installation. Align the swing arm pivot with upper link pivot point and bearing cap (Image #12).

B Insert non-drive D-lock reducer Flip Chip (#130865) and drive side D-lock reducer to join top link with rear triangle (Image #13).

C Install upper link spacer (#130821) on the back side of D-lock reducer on both drive and non-drive sides (Image #14/14a).

INSTALLING REAR SHOCK //

A With the rear shock reservoir oriented up, align the forward end of shock to the shock mount on front triangle. Install greased shock shoulder bolt right (#410050) thru shock mount and tighten to 7 Nm or 60 in/lbs (Image #15).

B Align rear of shock to D-Lock reducers and link spacers on the top link, insert shock shoulder bolt left into the D-Lock reducer on the non drive side (Image #16/16A).

C Confirm the D-Lock shoulder bolt is keyed and completely inserted into the D-Lock reducer on the non drive side. On the drive side, thread drive side RT Nut (#130814) on to shock shoulder bolt left (#130813). Using a 5 mm HEX wrench, torque to 16 Nm or 140 in/lbs (Image #17/17A).



18



19



20



21



22



23



24



25

INSTALLING DERAILLEUR HANGER //

A Grease portion of derailleur hanger (#130790) where it interfaces with the frame. Apply blue loctite to derailleur bolt.

C Torque derailleur bolt (#130798) to 11 Nm or 100 in/lbs (Image #19).

B Insert hanger into back of frame opening and align derailleur bolt (#130798) with threads in the hanger (Image #18).

REAR AXLE //

A Grease and install adjuster cone (#130807) in the head of the axle, grease M6 x 22 mm bolt (#410032) through adjuster cone into axle (Image #20) and thread into the rear axle.

B Insert 148 x 12 rear axle (#130757) into axle opening on non-drive side (Image #21).

C With the rear wheel and axle installed, insert a 5 mm HEX key through derailleurs cap on the drive side to reach the 5 mm hex interface on the inside of the axle. Turn wrench counter clock wise to tighten the axle. Torque to 11 Nm or 100 in/lbs (Image #22).

D On the non drive side, use a 5 mm HEX wrench and torque the cone adjuster to 14Nm or 125 in/lbs (Image #23).

SEAT CLAMP //

A Install seat clamp on frame, note that the serial number is on this area of the front triangle (Image #24).

B Grease and install M6 x 18 mm bolt through the drive side of seat clamp (Image #25), when seat post is installed torque the seat clamp to 5 Nm or 45 in/lbs.

TORQUE SPECIFICATIONS //

Achieving proper torque is vital to ensuring the safe performance and function of the Primer 29 frame. Failure to do so could result in sub-optimal performance of your frame as well as premature wear and tear of individual parts.

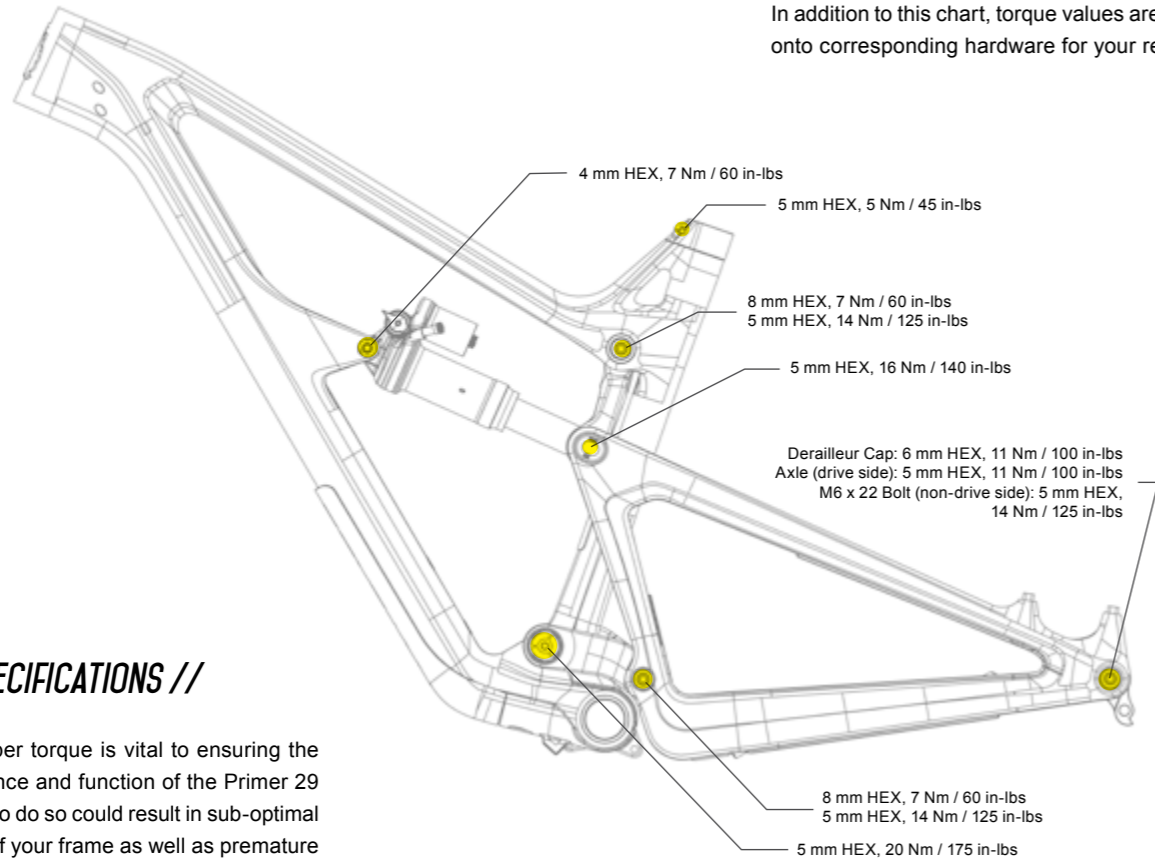

ADDITIONAL REFERENCE

In addition to this chart, torque values are laser etched onto corresponding hardware for your reference.

SETUP

PREFACE //

We are almost ready to rip. Just a few more checkpoints and adjustments to ensure the performance and ride characteristics of the Primer 29 are optimised for you.

TOOLS NEEDED

- shock pump
- small ruler or measuring device
- torque wrench
- Intense Carbon Paste



SEATPOST //

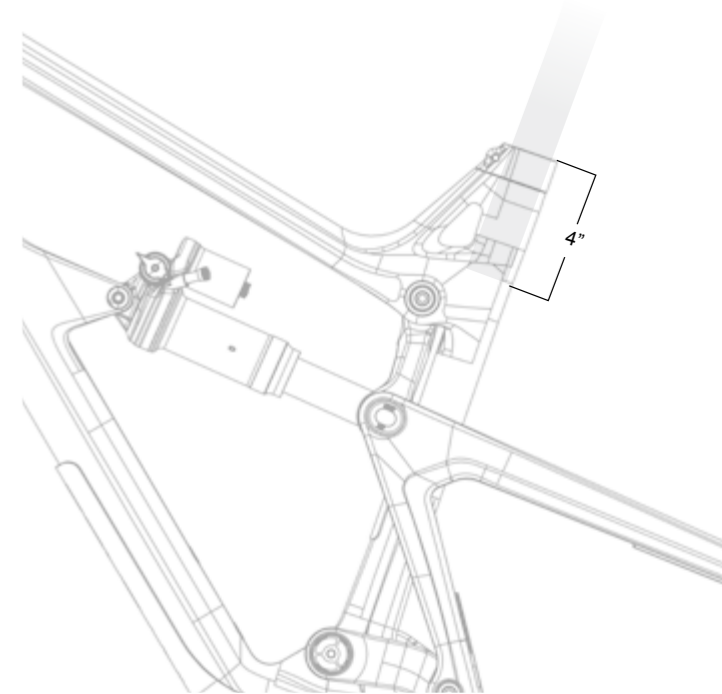

Before insertion, liberally coat the seat post with carbon paste and gently slide into the seat tube. With a minimum seat post insertion of 4", tighten seat post clamp to 5 nm / 45 in-lbs. (Over tightening the seat post clamp will inhibit the movement of the seat post and potentially damage seat post and/or seat tube.)



SETTING THE SAG //

1. Remove fork and shock air caps and be sure you have a shock pump and a small ruler or measuring device handy.
2. Go ahead and hop on the bike. Be sure to place all your weight on the seat with the dropper in the up position and both hands on the grips.
3. Give the bike 5-6 moderate bounces and sit back down on the saddle.
4. Now have your friend slide both the rear shock and the front fork o-rings down against the seal lip of the damper bodies (Image #1).
5. Step off the bike nice and easy. Be sure to not compress the suspension after the o-rings have been set.

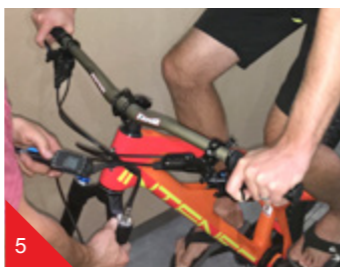
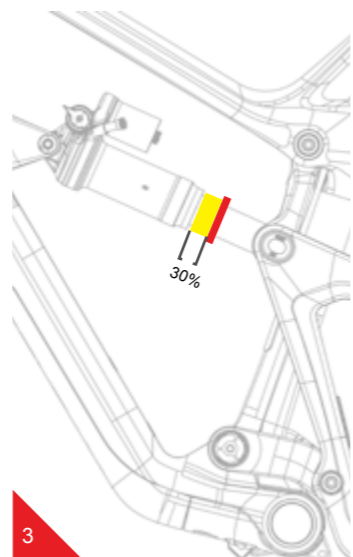
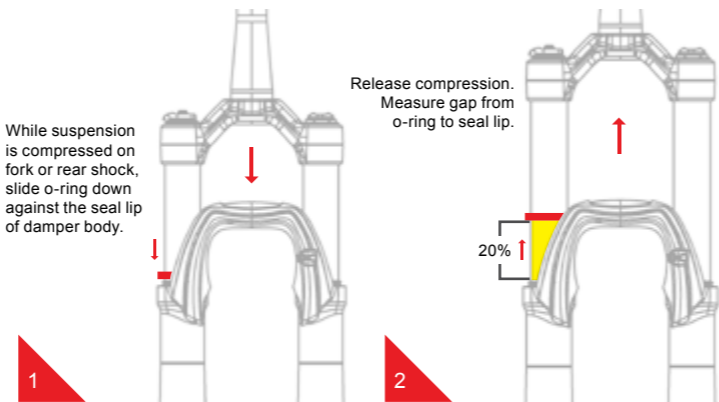

PRO TIP

Here is where having a friend helps. Have them straddle the front wheel and pull the handle bars in a upward direction as to not allow the suspension to compress as you get off (Image #4).

6. Using your measuring device, measure the gap between the suspension seal lip and the o-ring. Using the chart on the following page will tell you if you need more air pressure or less air pressure (Images #2, #3).
7. Adjust air pressure with your shock pump accordingly (Image #5).
8. Re-visit steps 2-6 until your desired sag measurement have been reached.
9. Install valve caps.

SHOCK SETUP //



FOX FLOAT DPX2
210 X 50 MM



Proper set up and tuning can vary from shock to shock. Please consult the Fox manual included with your bike for complete information about set up, tuning and general maintenance or visit www.foxracingshox.com.

TRAVEL		Low Setting: 140 mm (5.5 inch)	
TRAVEL		Lower Setting: 137 mm (5.4 inch)	
SHOCK STROKE		50 mm (2 inch)	
SHOCK SAG		30% when sitting on the bike	
FORK SAG		20% when sitting on the bike	
SHOCK		Fox Float DPX2 Shock 210 x 50 mm	
RIDER WEIGHT [LBS/KGS]	AIR PRESSURE [PSI]	REBOUND (clicks out from fully closed) Closed is Clockwise Open is Counter Clockwise	
		LOW SPEED COMPRESSION	
100 LBS / 45 KGS	130	11	10 Clicks Out
110 LBS / 50 KGS	140	10	
120 LBS / 54 KGS	155	9	
130 LBS / 59 KGS	165	9	
140 LBS / 63.5 KGS	185	8	8 Clicks Out
150 LBS / 68 KGS	195	8	
160 LBS / 73 KGS	205	7	
170 LBS / 77 KGS	215	7	
180 LBS / 82 KGS	225	7	6 Clicks Out
190 LBS / 86 KGS	240	6	
200 LBS / 91 KGS	250	6	
210 LBS / 95 KGS	260	5	
220 LBS / 100 KGS	275	4	6 Clicks Out
230 LBS / 104 KGS	285	3	
240 LBS / 109 KGS	300	2	
250 LBS / 113 KGS	310	2	

FLIP CHIP: LOW AND LOWER SETTINGS //

The Low (Image #1) and Lower (Image #2) settings of the Flip Chip allows you to optimize the performance characteristics of the Primer 29 by altering the frame's geometry. In general, the Lower setting results in a more 'slack' geometry with a decreased head tube angle, lower BB height as well as a lower standover height. For a detailed understanding of exactly how the geometry is affected, please refer to the geometry chart located on page 5.



ADDITIONAL NOTES

- To get the rear triangle and the flip chip to completely install in the Lower setting, the rear triangle will "start" into the rear travel before the flip chip is fully engaged and locked into place. This does decrease the useable rear suspension travel slightly to obtain this more slack lower geometry position.
- The front and rear tires, in addition to traction and grip performance, act as a secondary component of suspension. Adjusting the tire characteristics can help you further optimize the Primer 29's performance.

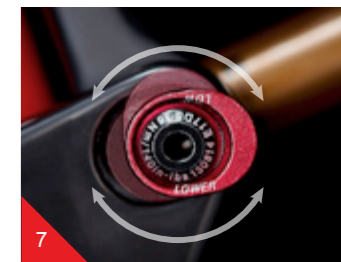
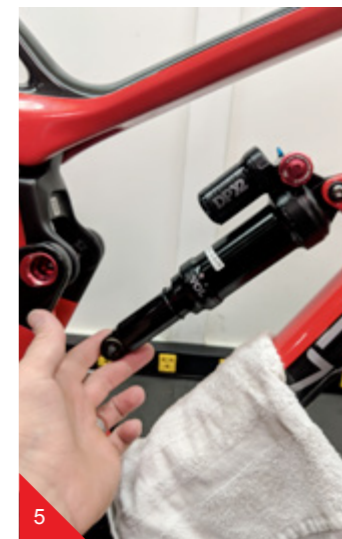

HOW TO FLIP THE FLIP CHIP //

A On the drive side, use a 5 mm HEX wrench and loosen and remove the drive side RT Nut (#130814) (Image #3).

B From the non drive side remove the D-Lock shoulder bolt (#130813) completely (Image #4).

C On the drive side, while holding the back of the shock with left hand, loosen the front shock bolt (#410050) with 4 mm HEX wrench in right hand, push down on rear shock and lower the back of the shock out of the way, then snug the front shock bolt to hold shock and prevent it from hitting on the frame (Image #5).

D Remove the two left and right upper link spacers (#130821) (Image #6). Push out the Flip Chips (#130865 and #130866) so the Chip head clears the rear triangle. Flip the Chips 180 degrees to the next setting (either Lower or Low) (Image #7). Re-install hardware and shock following the steps detailed on pages 12 and 13.

MAINTENANCE

GENERAL SERVICE AND CARE //

You have purchased a high performance bicycle which requires a certain level of service and maintenance to sustain the level of performance your frame was designed around. Proper care will also ensure the bike is safe to ride at all levels. It is important to read and understand the carbon care information as well as follow the maintenance schedule and inspect your bicycle before each ride. These will not only help to limit or avoid costly repairs but will also help to avoid injury due to service neglect and component failure.

CARBON CARE //

Intense Cycles employs advanced composite techniques and materials in our frames which do require a certain level of care and maintenance to ensure a safe experience at the high level of performance each frame is designed around. Not following these guidelines will decrease the level of performance and possibly cause injury or death.

- Use a soft cloth with warm soapy water to clean the carbon surfaces. Do not use high pressure washers, abrasive cloths or cleaners.
- Be sure all frame surfaces in contact with cables are protected. Cable housing rubbing on carbon can wear over time.
- Be sure brake levers, handle bar ends and the fork crown do not contact the frame at full rotation.
- Never clamp any part of a carbon frame in a bike stand or car rack.
- Always inspect your frame if you experience any chain suck.
- Always inspect your frame in full after a crash to be sure there is no damage. Look for cracks, dents or loose fibers. If you discover damage in any degree it's best to have your frame inspected by a qualified Intense Cycles dealer. Any direct impact to the frame can cause serious structural damage.
- Use high grade waterproof grease on seat post, BB and head set bearing contact areas with the carbon.
- Never ream or face a carbon frame.
- Be sure to follow all recommended torque settings.
- Use only genuine replacement parts for safety-critical components.



MAINTENANCE SCHEDULE* //

	ACTION	EVERY RIDE	500 MILES OR 1 MONTH	2000 MILES OR 6 MONTHS	4000 MILES OR 1 YEAR
TIRES	Check air pressure, inspect tread and sidewalls for tears and punctures	X			
CHAIN	Brush off and lubricate	X			
BRAKES	Squeeze brakes and confirm function	X			
GENERAL	Clean complete bike of mud and debris		X		
HEADSET	Check adjustment		X		
BOX LINK	Add grease thru zerk fittings		X		
FRAME PIVOTS	Check torques		X		
SPOKES	Inspect for damage, check tension		X		
SHOCK AND FORK	Check air pressure, inspect for leaks		X		
DERAILEUR CABLES	Inspect and lube			X	
SEATPOST	Clean and regrease interface with frame			X	
FRAME PIVOTS	Remove pivot bolts, check bearings for pitting and wear			X	
HEADSET	Disassemble stem, headset and fork. Check bearings for pitting and wear			X	
HUBS	Pull wheels off, check hub bearings for pitting and wear			X	
BOTTOM BRACKET	Remove crank arms and check BB bearings for pitting and wear			X	
BRAKES	Replace brake pads			X	
CHAIN	Inspect for damage and check for stretching			X	
GENERAL	Complete Tune-Up				X
SHOCK AND FORK	Overhaul				See MFG Recommendations

* The above maintenance schedule is only a guideline. Refer to component manufacturer for specific instruction on maintaining their parts.

WWW.INTENSECYCLES.COM

PHONE:

+1[951]-307-9211

CUSTOMER SERVICE:

TECHCENTER@INTENSECYCLES.COM

GENERAL INFO:

INFO@INTENSECYCLES.COM

MEDIA, MARKETING, SPONSORSHIP:

MARKETING@INTENSECYCLES.COM

INTENSE LLC 42380 RIO NEDO TEMECULA, CA. 92590