



INTENSE
CYCLES.USA

USER MANUAL // TAZER

WELCOME TO THE FAMILY

*AT INTENSE, WE HAVE ONE GOAL -
TO PROVIDE THE RIDE OF YOUR LIFE //*

Our team of designers, engineers and product experts are focused on one thing every day: your experience on the bike. We build bikes that are as thrilling to look at as they are to ride, and we build them for the select few of you who understand the difference and refuse to settle for anything else. From the early days of Intense, when founder Jeff Steber worked alone in his garage to today, where a crew of talented people work in a Temecula, CA factory, Intense has been a brand built on passion by forward thinkers who, even today, love nothing more than to throw a leg over a sweet bike and head out for a rip. We're so glad you've joined us. Welcome to Intense, enjoy your experience.

REGISTER YOUR BIKE //

www.intensecycles.com/warranty-card/

TECHNICAL ASSISTANCE

techcenter@intensecycles.com

951-307-9211

THE TAZER //

More than an eBike, think of the Tazer as an Intense bike that happens to have an E-assist feature. Built with aggressive trail geometry, Jeff Steber tuned kinematics and 29"/27.5" front and rear wheel sizes, this bike delivers a unique ride for an eMTB that won't feel cumbersome and has a seamless pedal-to-power transition.

#NOSHUTTLEREQUIRED



TABLE OF CONTENTS //

| | |
|------------------------------------|----|
| Introduction / Registration | 2 |
| Unboxing | 4 |
| Get Charged / Build | 5 |
| Connect the System. | 7 |
| Suspension Setup | 8 |
| Frame Features / Component Spec | 10 |
| Geometry | 11 |
| Exploded View and B.O.M. | 12 |
| Torque Chart | 15 |
| Unique Identifiers | 16 |
| About the Battery | 17 |
| Installing / Removing Battery | 20 |
| Turning the Power On / Off | 22 |
| Cycle Computer Display and Setting | 23 |
| Assist and Shift Switches | 24 |
| Maintenance | 26 |
| Troubleshooting | 28 |
| E-bike Declaration of Conformity | 30 |

SETUP

PREFACE //

Before you can get out there and rip up the trails, we need to get your bike unpacked and built up. This is a good chance for you to become familiar with your bike and to ensure the performance and ride characteristics of the Tazer is optimised for you.

TOOLS NEEDED

- shock pump
- small ruler or measuring device
- torque wrench
- Intense Carbon Paste



UNBOXING YOUR TAZER //

Careful attention has been given to the packaging of your Intense Tazer to not only ensure that it arrives safely and undamaged, but also that you are able to re-use the packaging for situations in which you need to safely transport your bike.

1. Rest the box on the ground or stable surface with the top side facing up.
2. Pull the flaps and open the top lid.
3. Remove the INTENSE accessory box, which contains your user manual, torque wrench, and shock pump.
4. Everything in the box is numbered. Remove the inserts in chronological order taking care not to rip or tear the cardboard so that they can be reused in the future.
5. After removing the handlebar and control protector (#7), raise the dropper post by activating the trigger located on the handlebar.
6. Mount the frame onto a bike stand using the seatpost as your clamping surface. **WARNING:** Do not clamp onto any of the carbon surfaces of the frame as this could severely damage the frame.
7. Continue by removing the remaining protectors from the bike.

PACKAGING IDENTIFIERS

- | | |
|-----------------------------------|------------------------------------|
| 1. Frame spacer | 6. Cassette cover |
| 2. Wheel stabilizer (front wheel) | 7. Handlebar and control protector |
| 3. Wheel stabilizer (rear wheel) | 8. Fork cover |
| 4. Rear wheel cover | 9. Downtube / toptube protector |
| 5. Front wheel cover | |

GET CHARGED //

The battery is not fully charged at the time of purchase, so before you start building your Tazer, take a moment to unpack and charge the supplied Shimano battery using its dedicated charger. Be sure to charge the battery until it is fully charged. See page 18 for more information about charging the battery.

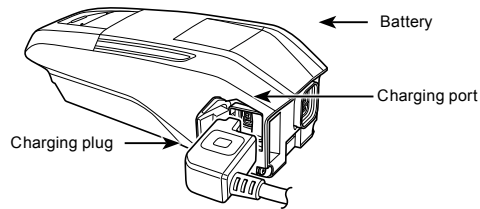

IMPORTANT NOTE: Keep the Shimano battery box and original internal packaging for potential future returns to Shimano.

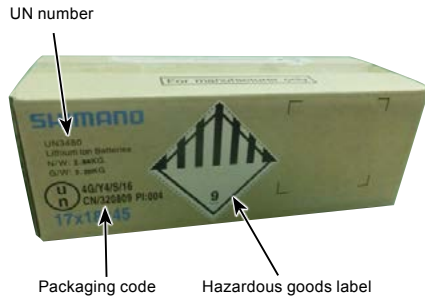

BUILDING YOUR TAZER //

Once all the protectors have been removed from the bike, we can begin the process of mounting the components onto the frame.

HANDLEBAR INSTALLATION

1. Spin the stem around so that the faceplate is facing forward.
 2. Using a 4 mm allen key, remove the faceplate from the stem.
 3. Making sure that all the cables are oriented properly, place the handlebar into the stem and reinstall the faceplate.
- With the handlebar centered, torque the faceplate bolts to 6 Nm / 54 in-lbs. **NOTE:** Take your time when installing the faceplate bolts to prevent any type of cross threading.

PRO TIP

When installing the faceplate, always tighten the stem bolts in a cross pattern (top left – bottom right, bottom left – Top right).

MOUNTING THE DERAILLEUR

1. Using a knife or scissors, carefully remove the bubble wrap and zipties from the rear derailleur, chain, and B-screw.
2. With a 5mm allen key, mount the rear derailleur onto the derailleur hanger being careful to avoid cross threading.
3. Using a torque wrench, tighten the derailleur bolt to 8-10 Nm / 70-90 in-lbs.

INSTALLING THE REAR WHEEL

1. Remove the brake pad spacers from the rear brake. Be sure to keep this in a safe spot so it can be reused in the future.
2. Remove the rear axle.
3. Grab the rear wheel and carefully remove the disc guard. Check the disc guard to make sure the end cap is not accidentally removed with the guard.
4. Pull the derailleur back and slide the rear wheel into the rear triangle of the bike, setting the chain on the smallest gear of the cassette.
5. From the non-drive side, slide the axle through the dropout and wheel assembly, threading it by hand in a clockwise direction.
6. Using a 5mm allen key from the drive side, tighten the axle in a counter clockwise direction. Torque to 11 Nm / 100 in-lbs.
7. From the non-drive side, tighten the cone spacer with a 5mm allen key. Torque to 14 Nm / 125 in-lbs.

INSTALLING THE FRONT WHEEL

1. Grab the front wheel and carefully remove the disc guard.
2. Remove the front axle as well as the pad spacer from the front brake. Be sure to keep the pad spacer in a safe spot for future use.
3. With the rotor side of the wheel on the non-drive side of the bike, line the brake caliper up with the disc rotor carefully sliding the front wheel between the fork legs.
4. Slide the axle through the fork dropout and wheel assembly and tighten by turning in a clockwise direction. **NOTE:** To prevent accidental opening of the quick release lever while riding, always lock the lever in an upward direction (parallel to the fork leg) or horizontally towards the rear of the bike.

QUICK COMPONENT CHECK

All INTENSE bicycles are delivered "Ride Ready", meaning you can expect the bikes to come with the brakes and drivetrain all properly adjusted. However, to ensure that nothing happened during shipping, we recommend that you check that all the components are operating correctly before heading out to the trail.

1. One wheel at a time, spin the wheels to make sure there is no rotor rub from the brake pads. Give the brakes a squeeze to make sure everything feels alright.
2. Check that the derailleur is adjusted properly by running up and down the gears making sure that everything is functioning nice and smoothly.

SETTING PRELOAD ON THE HEADSET AND TIGHTENING THE STEM

1. Remove the bike from the stand and place it onto the ground.
2. Check that front wheel is inline with the stem.
PRO TIP: You can line up the back of the handlebar with the front of the fork crown to help with alignment.
3. Set the preload on the headset by tightening the bolt in the center cap.
4. Tighten stem bolts with 5mm allen key and torque to 8 Nm / 70 in-lbs.

SEAT POST

When inserting the seat post, apply a liberal coat carbon paste and gently slide it into the seat tube. With a minimum seat post insertion of 4" (100mm), tighten seat post clamp to 5 Nm / 45 in-lbs. **NOTE:** Over tightening the seat post clamp will inhibit the movement of the seat post and potentially damage seat post and/or seat tube.

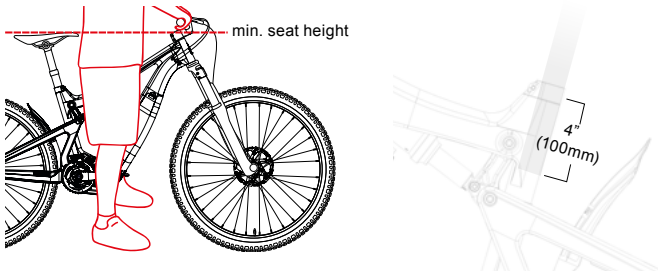

CONNECTING THE SYSTEM //

Now that your bike is built, we need to plug the electric wire that can be found coming out of the down tube (drive side) into the back of the cycling computer as shown below.

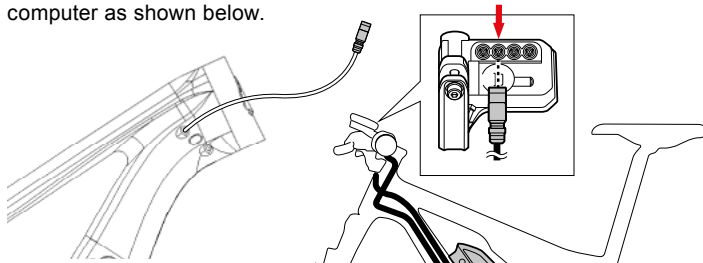

CONNECTING THE ELECTRIC WIRE

Use the Shimano original tool (TL-EW02) for installation and removal of the electric wire. Set so that the projection on the connector is aligned with the groove on the narrow end of the tool.

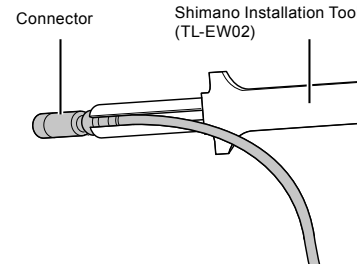

When installing the electric wire, do not forcibly bend the connector. It may result in a poor contact. When connecting the electric wire, push it in until it clicks in place.

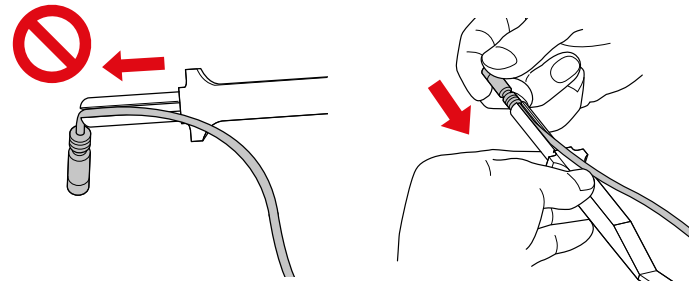



SETTING THE SAG //

1. Remove fork and shock air caps and be sure you have a shock pump and a small ruler or measuring device handy.
2. Go ahead and hop on the bike. Be sure to place all your weight on the seat with the dropper in the up position and both hands on the grips.
3. Give the bike 5-6 moderate bounces and sit back down on the saddle.
4. Now have your friend slide both the rear shock and the front fork o-rings down against the seal lip of the damper bodies (Image #1).
5. Step off the bike nice and easy. Be sure to not compress the suspension after the o-rings have been set.

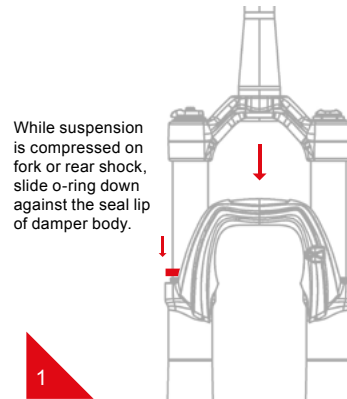

1

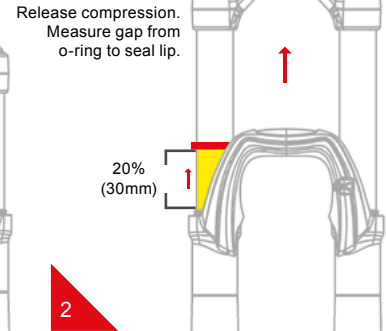

2

20%
(30mm)

PRO TIP

Here is where having a friend helps. Have them straddle the front wheel and pull the handle bars in an upward direction as to not allow the suspension to compress as you get off (Image #4).

6. Using your measuring device, measure the gap between the suspension seal lip and the o-ring. Using the chart on the following page will tell you if you need more air pressure or less air pressure (Images #2, #3).
7. Adjust air pressure with your shock pump accordingly (Image #5).
8. Re-visit steps 2-6 until your desired sag measurement have been reached.
9. Install valve caps.

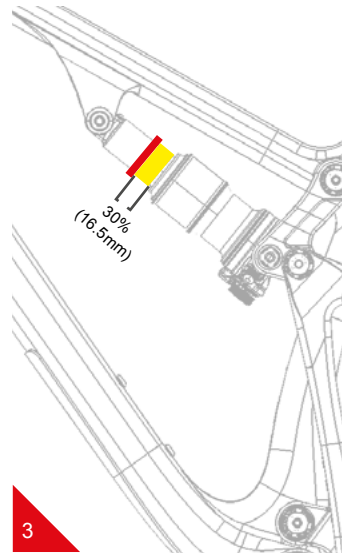

3



4

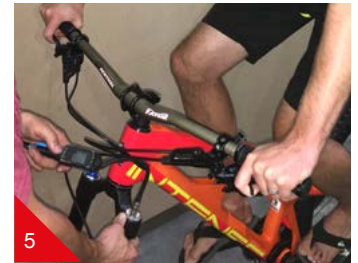

5

SHOCK SETUP //

Proper set up and tuning can vary from shock to shock. Please consult the Fox manual included with your bike for complete information about set up, tuning and general maintenance or visit www.foxracingshox.com

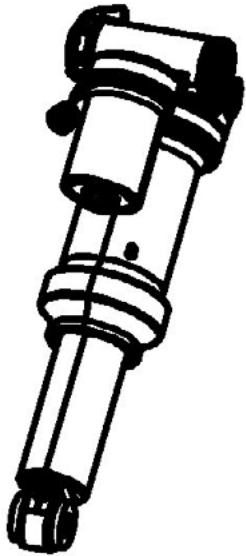

NOTE:

- FLOAT DPX2 shocks have a maximum pressure of 350psi (24.1 bar).
- Max rider weight for the DPX2 shock on the Tazer is 250 lbs / 113 kg based on 30% sag requirement and DPX2 shock max air pressure of 350 psi.
- Max rider weight for TAZER frame is 300 lbs / 136 kg.
- Please contact the Intense Cycles Tech Center for shock fitment options.



FOX FLOAT DPX2
185 X 55MM

| TRAVEL | 155 mm (6.1") | | |
|---------------------------|----------------------------------|---|--------------------------|
| SHOCK STROKE | 55 mm (2.15") | | |
| SHOCK SAG | 30% when sitting on the bike | | |
| FORK SAG | 20% when sitting on the bike | | |
| SHOCK | Fox Float DPX2 Shock 185 x 55 mm | | |
| RIDER WEIGHT (LBS/KGS) | AIR PRESSURE (PSI) | REBOUND (CLICKS OUT FROM FULLY CLOSED) Closed is Clockwise Open is Counter Clockwise | LOW SPEED COMPRESSION |
| 100 LBS/ 45 KGS | 130 | 11 | 10 Clicks Out |
| 110 LBS/ 50 KGS | 145 | 10 | |
| 120 LBS/ 54 KGS | 160 | 9 | |
| 130 LBS/ 59 KGS | 175 | 9 | |
| 140 LBS/ 63.5 KGS | 190 | 8 | |
| 150/ 68 KGS | 205 | 8 | 8 Clicks Out |
| 160/ 73 KGS | 220 | 7 | |
| 170/ 77 KGS | 235 | 7 | |
| 180/ 82 KGS | 250 | 6 | |
| 190/ 86 KGS | 265 | 6 | |
| 200/ 91 KGS | 280 | 5 | 6 Clicks Out |
| 210/ 95 KGS | 295 | 5 | |
| 220/ 100 KGS | 310 | 4 | |
| 230/ 104 KGS | 325 | 3 | |
| 240/ 109 KGS | 340 | 2 | |
| 250/ 113 KGS | 350 | 2 | |

GETTING TO KNOW YOUR TAZER

WARNING

Use the supplied key to remove the battery from the frame to perform battery swap or for charging. Do not move or alter the battery frame mounts from their factory position in the downtube as this could result in subpar performance, may lead to battery and or frame damage and is not covered under warranty. Please contact Intense Cycles Tech Center if you have any questions relating to the battery mounts.

FRAME FEATURES //

- Rear Travel: 155mm / 6.1 inches with metric 185 x 55 stroke shock
- 29" Front Wheel size, 27.5" x 2.80" Plus Rear Wheel size
- Progressive Shock Curve
- Integrated 148 x 12mm dropouts
- Internal Cable Routing
- Flack Guard: Downtube, Chainstay, Seatstay and Seattube protection
- Molded: Rear Fender
- Tapered Head Tube
- Replaceable Grease Zerk on back of Lower Link
- Max Bearings and Dedicated Frame Hardware
- Molded Skid plate
- Removable Battery

COMPONENT SPEC //

- Fork: Accepts 1.125" straight steer or 1.125"/1.5" tapered steer, 160mm travel/ 6.3 inches, 567mm Axle to Crown, 51mm Offset
- Shock: 185mm x 55mm Metric Shock, Trunnion with 20mm x 8mm Reducers on shock
- Seat post: 31.6mm
- Headset: Zero Stack 49mm Upper/ 56mm Lower
- Rear Axle: BOOST 148 x 12mm
- Brake Mount: Post Mount for 200mm rotor
- Shimano E8000 Motor
- Shimano E8010 Battery

GEOMETRY //

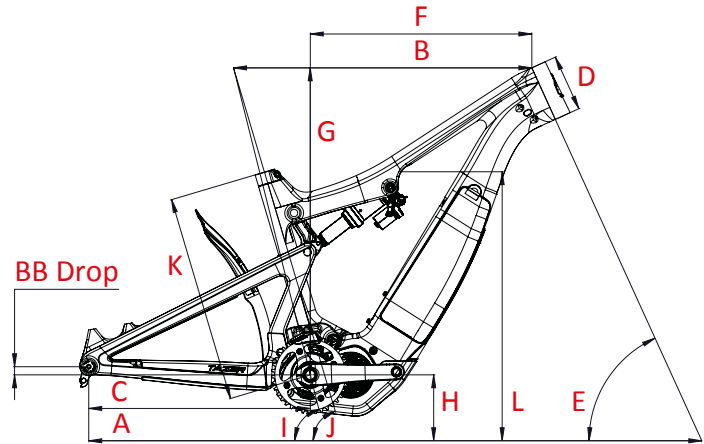

| | | SMALL | MEDIUM | LARGE |
|---|------------------------------|------------------|-----------------|----------------|
| A | Wheel Base: | 1199.4 mm/ 47.2" | 1230 mm/ 48.4" | 1260 mm/ 49.6" |
| B | Top Tube Length: | 577 mm/ 22.7" | 605 mm/ 23.8" | 633.4 mm/ 25" |
| C | Chain Stay Length: | 450 mm/ 17.7" | 450 mm/ 17.7" | 450 mm/ 17.7" |
| D | Head Tube Length: | 100 mm/ 3.94" | 115 mm/ 4.5" | 125 mm/ 4.9" |
| E | Head Tube Angle: | 64.9° | 64.9° | 64.9° |
| F | Reach: | 425 mm/ 16.7" | 450 mm/ 17.7" | 475 mm/ 18.7" |
| G | Stack: | 610 mm/ 24" | 623 mm / 24.54" | 632 mm/ 24.9" |
| H | BB Height: | 347 mm/ 13.65" | 347 mm/ 13.65" | 347 mm/ 13.65" |
| | BB Drop | 12 mm/ 0.47" | 12 mm/ 0.47" | 12 mm/ 0.47" |
| I | Seat Tube Angle (Effective): | 75.4° | 75.4° | 75.4° |
| J | Seat Tube Angle (Actual): | 72.9° | 72.9° | 72.9° |
| K | Seat Tube Length: | 394 mm/ 15.5" | 419 mm/ 16.5" | 445 mm/ 17.5" |
| L | Standover Height: | 806 mm/ 31.7" | 814.1 mm/ 32" | 822 mm/ 32.4" |

GEOMETRY NOTE

Geometry taken at top out with 567mm axle to crown length and 51mm fork offset.

COMPONENT SPEC NOTE

The Tazer is designed around the use of a single chain ring only. Use of a double or triple ring set will not allow proper clearance with the frame.

EXPLODED VIEW AND B.O.M. //

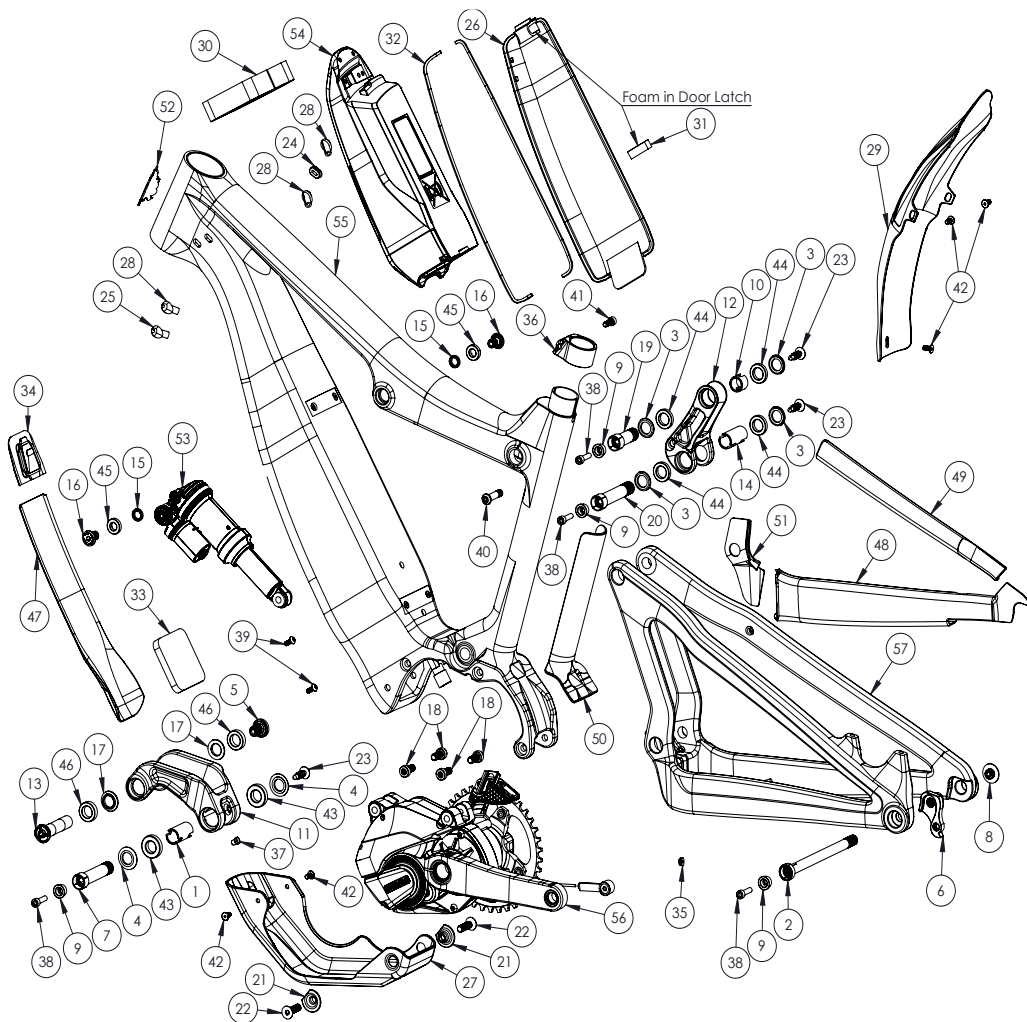

| ITEM NO. | ITEM | PART NUMBER | DESCRIPTION | QTY. | TORQUE SPEC. |
|----------|-----------------|-------------|---|------|-----------------------|
| 1 | Bearing Spacer | 130754 | Lower Link Bearing Spacer | 1 | N/A |
| 2 | Rear Axle | 130757 | Axle Rear 148 x 12mm Boost | 1 | 11 Nm / 100 in-lbs |
| 3 | Bearing Cap | 130765 | Upper Link Bearing Cap, 24mm | 4 | N/A |
| 4 | Bearing Cap | 130778 | Lower Link Bearing Cap, 28mm | 2 | N/A |
| 5 | Pivot Bolt | 130785 | Lower Link Pivot Bolt | 1 | 20 Nm / 175 in-lbs |
| 6 | Hanger | 130790 | Derailleur Hanger, Forged | 1 | N/A |
| 7 | Pivot Bolt | 130795 | Lower Link Expander Bolt (Lower Pivot) | 1 | 7 Nm / 60 in-lbs |
| 8 | Hanger Bolt | 130798 | Derailleur Hanger Bolt | 1 | 11 Nm / 100 in-lbs |
| 9 | Cone Adjuster | 130807 | Cone Adjuster, 8.3 mm Height | 4 | N/A |
| 10 | Bearing Spacer | 130847 | Upper Link Bearing Spacer (Upper Pivot) | 1 | N/A |
| 11 | Lower Link | 130848 | Forged Lower Link Tazer, Blk | 1 | N/A |
| 12 | Forged Top Link | 130849 | Forged Top Link Tazer, Blk | 1 | N/A |
| 13 | Axle Lower | 130850 | Axle Lower Pivot Tazer | 1 | 20 Nm / 175 in-lbs |
| 14 | Bearing Spacer | 130851 | Upper Link Bearing Spacer (Lower Pivot) | 1 | N/A |
| 15 | Bearing Spacer | 130852 | Shock Mount Bearing Spacer (Trunion Pivot) | 2 | N/A |
| 16 | Shock Bolt | 130853 | Trunion Pivot Shock Bolt | 2 | 16 Nm / 140 in-lbs |
| 17 | Bearing Spacer | 130860 | Lower Link Bearing Spacer (Upper Pivot) | 2 | N/A |
| 18 | Drive Unit Bolt | 130862 | Drive Unit Bolt M8 x 18 with T40 Broach | 4 | 10 Nm / 88 in-lbs |
| 19 | Pivot Bolt | 130863 | Upper Link Expander Bolt (Upper Pivot) | 1 | 7 Nm / 60 in-lbs |

| ITEM NO. | ITEM | PART NUMBER | DESCRIPTION | QTY. | TORQUE SPEC. |
|----------|-----------------------|-------------|---|------|-----------------------|
| 20 | Pivot Bolt | 130864 | Upper Link Expander Bolt (Lower Pivot) | 1 | 7 Nm / 60 in-lbs |
| 21 | Skidplate Spacer | 130867 | Skidplate Spacer | 2 | N/A |
| 22 | FHCS M8 x 30 | 130868 | Drive Unit/Skid Plate Bolt M8 x 1.25 x 30 mm | 2 | 10 Nm / 88 in-lbs |
| 23 | Plug | 140038 | Lower Link Pivot Plug | 3 | N/A |
| 24 | Cable Guide Plug | 140039 | Cable Guide Plug, Solid | 1 | N/A |
| 25 | Cable Guide Plug | 140040 | Guide Cable Plug, 5mm ID | 1 | N/A |
| 26 | Battery Door | 140050 | Battery Door | 1 | N/A |
| 27 | Skid Plate | 140051 | Skid Plate | 1 | N/A |
| 28 | Cable Guide Plug | 140052 | Guide Cable Plug, 4mm ID | 3 | |
| 29 | Rear Fender | 140054 | Rear Fender | 1 | N/A |
| 30 | Battery Pull Strap | 140055 | Battery Pull Strap | 1 | N/A |
| 31 | Foam Pad | 140056 | Battery Door Foam Pad | 1 | N/A |
| 32 | Gasket | 140057 | Battery Door Gasket | 1 | N/A |
| 33 | Foam Pad | 140058 | Battery Compartment Foam Pad | 1 | N/A |
| 34 | Battery Charge Window | 140059 | Battery Charge Window | 1 | N/A |
| 35 | Grommet | 140060 | Speed Sensor Wire Grommet | 1 | N/A |
| 36 | Seat Clamp | 340342 | Bolt-on Seat Clamp | 1 | N/A |
| 37 | Zerk Fitting | 401011 | M6 x 1.0 | 1 | 5 Nm / 40 in-lbs |
| 38 | SHCS M6 x 22 | 410009 | Cone Adjuster Bolt, Socket Head, M6 x 22 | 4 | 14 Nm / 125 in-lbs |

(continued on next page)

| ITEM NO. | ITEM | PART NUMBER | DESCRIPTION | QTY. | TORQUE SPEC. |
|----------|----------------------|-------------|---|------|--|
| 39 | BHCS M5 X 12 | 410010 | Skid Plate Bolt, Button Head, M5 X 12 | 2 | 6 Nm / 54 in-lbs |
| 40 | SHCS M8 x 35 | 410045 | Shock Bolt, M8 x 35 Steel | 1 | 16 Nm / 140 in-lbs |
| 41 | SHCS M6 x 18 | 410048 | Seat Clamp Bolt, Socket Head, M6 x 18 | 1 | 5 Nm / 45 in-lbs |
| 42 | M5 x 11 | 410068 | Fender / Skidplate Bolt, Low profile Socket Head, M5 x 11 | 5 | 1 Nm/9 in-lbs (Fender) 2Nm/18in-lbs (Skidplate) |
| 43 | Bearing 7902 | 430007 | 15 x 28 x 7 2RS MAX Angular Contact Bearing | 2 | N/A |
| 44 | Bearing 6802 | 430008 | 15 x 24 x 5 2RS MAX Radial Bearing | 4 | N/A |
| 45 | Bearing 6800 | 430011 | 10 x 19 x 5 2RS MAX Radial Bearing | 2 | N/A |
| 46 | Bearing 3802 | 430014 | 15 x 24 x 7, Double Row Radial Bearing | 2 | N/A |
| 47 | Flack Guard Downtube | 500301 | Flack Guard Tazer Downtube | 1 | N/A |
| 48 | Flack Guard CS | 500302 | Flack Guard Tazer Chainstay | 1 | N/A |
| 49 | Flack Guard | 500303 | Flack Guard Tazer Seatstay | 1 | N/A |
| 50 | Flack Guard | 500304 | Flack Guard Tazer Seat Tube Protector | 1 | N/A |
| 51 | Flack Guard | 500305 | Flack Guard Tazer RT Strut | 1 | N/A |
| 52 | Head Badge | 500335 | Head Badge Flame Logo | 1 | N/A |
| 53 | Rear Shock | | 185 x 55, Trunnion | 1 | N/A |
| 54 | Battery | | Shimano E8010 | 1 | N/A |
| 55 | Front Triangle | | Carbon, 3 Sizes | 1 | N/A |
| 56 | Motor | | Shimano E8000 | 1 | N/A |
| 57 | Rear Triangle | | Carbon, 1 Size | 1 | N/A |



TORQUE SPECIFICATIONS //

Achieving proper torque is vital to ensuring the safe performance and function of the tazer frame. Failure to do so could result in sub-optimal performance of your frame as well as premature wear and tear of individual parts.

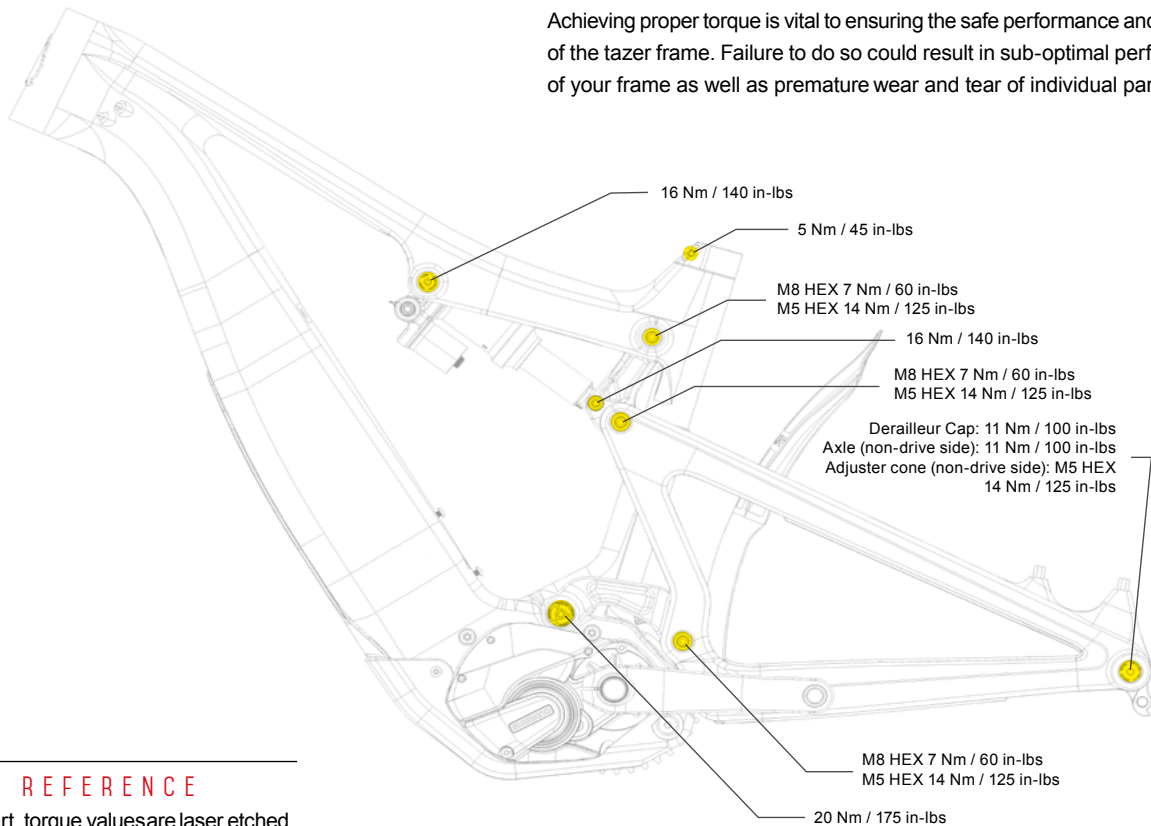

ADDITIONAL REFERENCE

In addition to this chart, torque values are laser etched onto corresponding hardware for your reference.

INTENSE BICYCLE IDENTIFICATION //

It's important to keep track of your Tazer's serial number as well as the serial numbers of its important components for warranty and replacement purposes. Included in your ACCESSORY KIT is a serial number sheet so this information can easily be tracked and stored in a safe place.

REGISTERING / REPLACING YOUR ABUS BATTERY KEY

Worried about losing your key or need to order a spare? No worries. However, to successfully order a replacement, you're going to need a few bits of information so, before its too late, do yourself a favor and document and register the unique identifiers of your key.



KEY TYPE: WAFER

KEY CODE:

KEY PROFILE:

To order your new key, head over to <https://mobilesecurity.abus.com> and click "Order Key" or visit your local ABUS dealer for help.



ABOUT THE BATTERY //

RIDING THE BICYCLE

1. Turn on the power.
 - a. You cannot use the battery immediately after shipment. Refer to "CHARGING THE BATTERY"
 - b. Do not place your feet on the pedals when turning the power on. A system error may result.
 - c. Power cannot be turned on while charging.
2. Select your preferred assist mode.
3. Assistance will start when the pedals start turning.
4. Change the assist mode in accordance with the riding conditions.
5. Turn the power off when parking the bicycle.
 - a. Do not place your feet on the pedals when turning the power off. A system error may result.

HANDLING AND CHARGING THE BATTERY

- Charging can be carried out at any time regardless of the amount of charge remaining, but you should charge the battery until it is fully charged
- Be sure to use the dedicated charger when recharging the battery.
- The battery is not fully charged at the time of purchase. Before riding, be sure to charge the battery until it is fully charged.
- If the battery has become fully spent, charge it as soon as possible. If you leave the battery without charging, it will cause the battery to deteriorate.
- If the bicycle will not be ridden over an extended period of time, store it away with approximately 70% battery capacity remaining. In addition, take care not to let the battery become completely empty by charging it every 6 months.
- The use of a genuine Shimano battery is recommended. Connect to E-TUBE PROJECT and click [Connection check] to confirm whether the battery in use is a genuine Shimano battery. If using a battery from another manufacturer, make sure to carefully read the instruction manual for the battery before use.

DANGER

Use the Shimano specified charger and observe the specified charging conditions when charging the specified battery. Not doing so may cause overheating, bursting, or ignition of the battery.

CAUTION

- When removing the battery charger power plug from the outlet or the charging plug from the battery, do not pull it out by the cord.
- When charging the battery while it is mounted on the bicycle, be careful not to trip over the charger cord or get anything caught on it. This may lead to injury or cause the bicycle to fall over, damaging the components.

BATTERY CHARGING

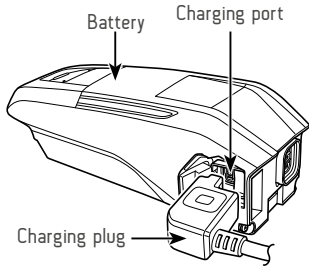

<BT-E8010>

- Battery can be charged in the Tazer frame or outside of Tazer frame.
- Pull back tab of rubberized cover on the back of the battery to access plug interface.
- For best charging results plug Shimano charger directly into a wall outlet, then plug charger into side of battery.
- Both the Shimano Battery and Shimano Charger indicator lights should light up, the yellow charger light shows it's charging. While the Green lights on the battery will blink as they are charging and be completely solid when fully charged.
- When Battery is completely charged, both it and the charger will turn off.



CHARGING TIME FOR THE 504 WH MODEL BATTERY

- 80% in 2.5 hours
- 100% in 5 hours

ABOUT THE CHARGER LED LAMP

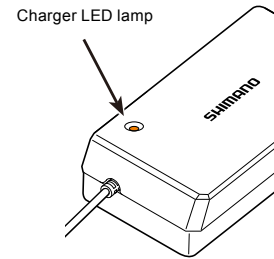
After charging has started, the LED lamp on the charger lights up.



| | |
|--|---|
|  Lit up | Charging (Within 1 hour after the completion of charging) |
|  Blinking | Charging error |
|  Turned off | Battery disconnected (1 hour or more after the completion of charging) |

ABOUT THE BATTERY LED LAMP

You can check the current charging status on the LED lamp on the battery.

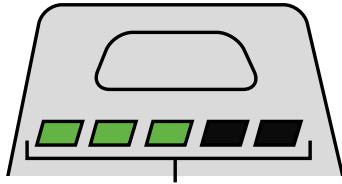

Battery LED lamps

[CHARGING-IN-PROGRESS INDICATION]

| BATTERY LEVEL INDICATION*1 | BATTERY LEVEL |
|----------------------------|---------------|
| | 0% - 20% |
| | 21% - 40% |
| | 41% - 60% |
| | 61% - 80% |
| | 81% - 99% |
| | 100% |

*1 : No light : Lit up : Blinking

BATTERY LEVEL INDICATION

The current battery level can be checked by pressing the battery's power button. **NOTE:** When remaining battery capacity is low, system functions begin to shut off in the following order.

1. Power assistance (Assist mode automatically switches to [ECO] and then assistance shuts off. The switch to [ECO] occurs earlier if a battery-powered light is connected.)
2. Gear shifting
3. Light

| BATTERY LEVEL INDICATION*1 | BATTERY LEVEL |
|----------------------------|--|
| | 100% - 81% |
| | 80% - 61% |
| | 60% - 41% |
| | 40% - 21% |
| | 20% - 1% |
| | 0% (When battery is not installed on bicycle) |
| | 0%, Power off / Shutdown (When battery is installed on bicycle) |

*1 : No light : Lit up : Blinking

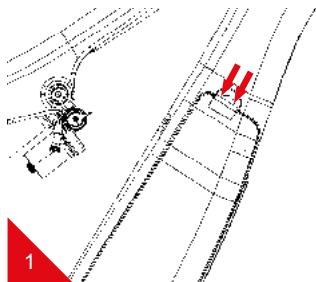

1

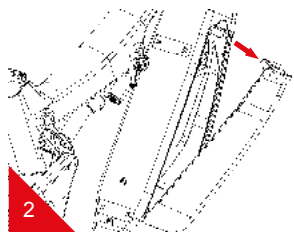

2

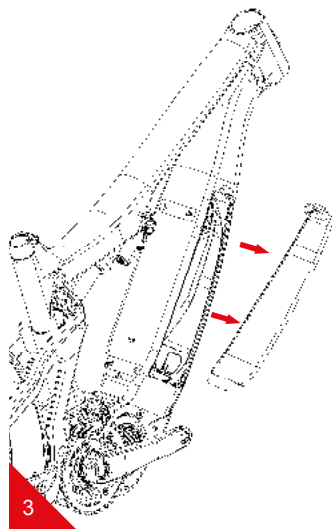

3



4

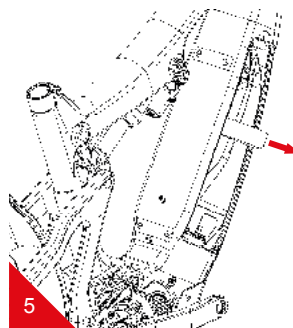

5

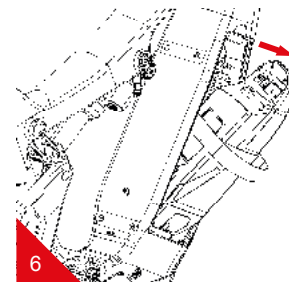

6

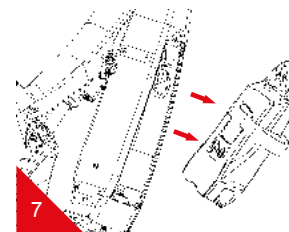

7

REMOVING THE BATTERY //

A Remove battery door by using two fingers to compress or pull the snap lock tab back toward the door. This will allow the door to pivot open so it is now angled off the downtube (Images #1, #2).

B Lift the door up at the angle it's at, freeing the lower locating tab from the frame (Image #3).

C With your right hand, insert battery key into lock.

D With your left hand, unfold and hold battery pull strap.

E Turn battery key a quarter turn with right hand (Image #4).

F Pull battery strap with left hand until the battery has moved past the front lock (Image #5).

G Release the key. The key can now be removed and placed in a safe, easy to access location.

H Continue pulling battery pull strap with left hand while holding onto the top of battery with right hand. The battery will continue to pivot off the lower mount and out of the downtube (Image #6).

I Lift the battery out and away from the downtube (Image #7).

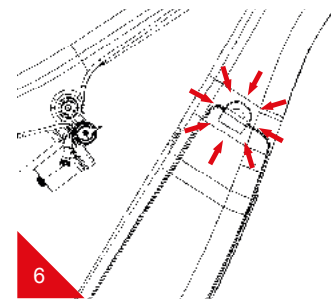
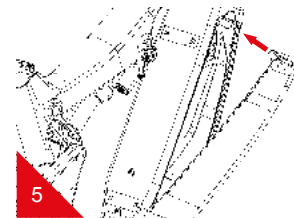
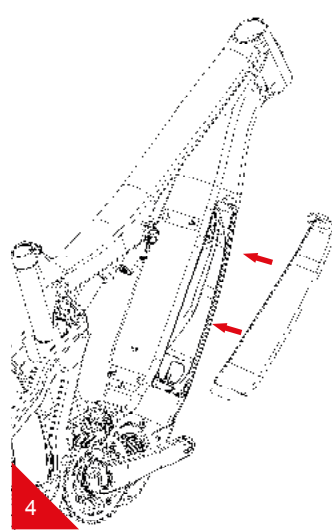
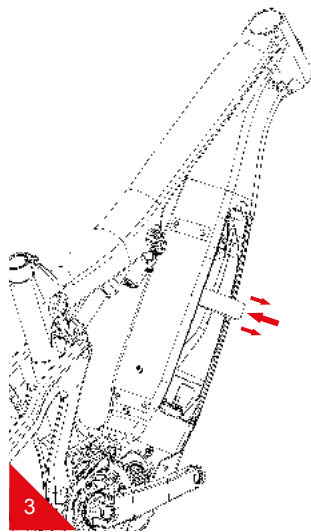
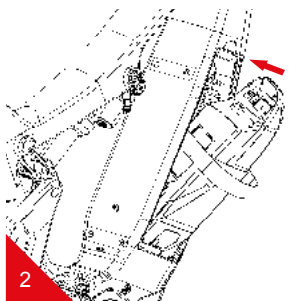
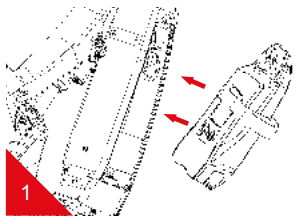

INSTALLING THE BATTERY //

A Place pull strap on battery as shown, then lift battery up with two hands, left hand on the pull strap and right hand at top of battery (Image #1).

B Angle the bottom of battery into the lower mount of the downtube and push it into the lower mount. The bottom of the battery should now be hooked into the lower battery mount. With it hooked it should now pivot

into the lower battery mount as the top of the battery is pushed toward the upper battery mount (Image #2).

C Continue pushing the top of the battery so that it slides into the upper mount then clicks and locks into place.

D Confirm the battery has clicked and is fully seated in the top battery mount by tugging on the

battery pull strap. If battery moves away from the mount then push it back against mount until battery is fully seated (Image #3). The battery pull strap can now be folded onto itself so it doesn't obstruct the battery door.

E Re-install the battery door with the lower tab fitting into the downtube opening first (Image #4).

F Once the battery door fully slides away from the mount then push it back into the door opening, pivot the door in a closing motion (Image #5).

G As the door is nearing the closed position at the top of the door give the door a good push to allow the door's snap lock feature to engage into the downtube (Image #6).

ABOUT THE CONTROLS

CABLE CONNECTING //

CONNECTING SWITCHES AND THE DRIVE UNIT TO THE CYCLE COMPUTER

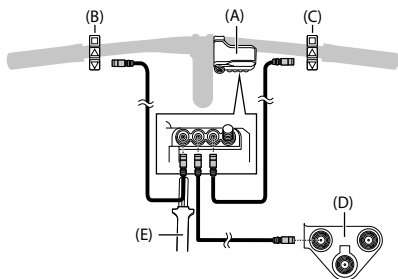

- A. Cycle computer**
- B. Assist switch**
- C. Shift switch**
(not spec'd for Tazer)
- D. Drive unit**
- E. TL-EW02**

NOTE:

- Be sure to attach dummy plugs to any unused ports.
- The electric wire connector can be connected to any port of the cycle computer, but we recommend you connect the assist switch to the switch-side port.

TURNING THE POWER ON/OFF //

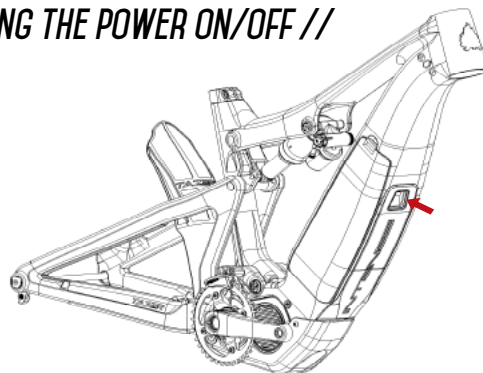

TURNING THE POWER ON AND OFF VIA THE BATTERY

- Press the power button on the battery. The LED lamps will light up indicating remaining battery capacity.

NOTE:

- When turning on the power, check that the battery is firmly attached to the holder.
- Power cannot be turned on while charging.
- Do not place your foot on the pedals when turning on. A system error may result.

AUTOMATIC POWER OFF FUNCTION

If the bicycle has not moved for over 10 minutes, the power will automatically turn off. **NOTE:** the system can be forced to power off by holding down the power button for 6 seconds.

CYCLE COMPUTER DISPLAY AND SETTING //

BASIC SCREEN DISPLAY

Displays the status of the power assisted bicycle, traveling data.

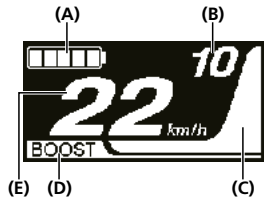

- A. Battery level indicator**
Displays the current battery level.
- B. Gear position**
Displays the currently set gear position. (Only displays when electronic gear shifting is in use)
- C. Assist gauge**
Displays the assistance.
- D. Assist mode display**
Displays the current assist mode. (Assist mode automatically switches to [ECO] as remaining battery capacity declines. The switch to [ECO] occurs earlier if a battery-powered light is connected.)
- E. Current speed**
Displays the current speed. The display can be switched between km/h and mph.

BATTERY LEVEL INDICATOR

You can check the battery level on the cycle computer while riding.

| DISPLAY | BATTERY LEVEL |
|---------|---------------|
| | 81% - 100% |
| | 61% - 80% |
| | 41% - 60% |
| | 21% - 40% |
| | 1% - 20%* |
| | 0% |

*The battery level indicator blinks red when remaining battery capacity falls to this level.

ASSIST AND SHIFT SWITCHES //

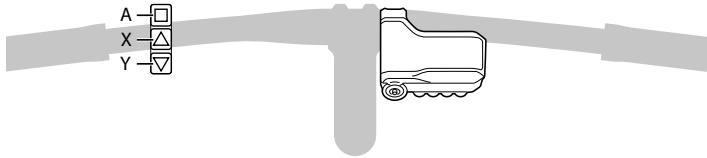

SW-E6000-L

| | |
|----------|--|
| X | Switching assist modes: the level of assistance becomes stronger |
| Y | Switching assist modes: the level of assistance becomes weaker |
| A | Changing the cycle computer display |

ASSIST MODES

To help maximize battery performance and efficiency, select an appropriate assist mode for your specific application.

BOOST //

Use when powerful assistance is required, such as when riding up steep uphill slopes. This mode is designed for use on steep inclines and precipitous mountains. When riding on level public roads with traffic lights, the assistance provided may be excessive, in which case, switch to [ECO] mode.

TRAIL //

Use when an intermediate level of assistance is needed, such as when you want to enjoy riding comfortably on a gentle slope or level ground.

ECO //

Use when you want to enjoy long distance riding on level ground. When pedaling is not very strong, the amount of assistance is reduced and energy consumption is lessened.

WALK //

This mode is particularly useful when walking the bicycle, taking the bicycle out up an incline or when it is bearing a heavy load. It is also useful when walking the bicycle across uneven terrain such as rocky areas.

CHANGING ASSIST MODE

Press X or Y to switch assist modes.

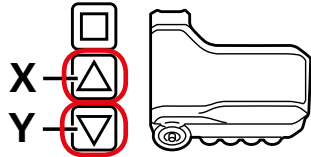

[SW-E6000-L / SC-E8000]



[SC-E8000]

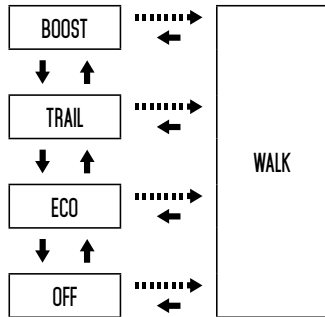

BOOST: ASSIST BOOST

TRAIL: ASSIST TRAIL

ECO: ASSIST ECO

OFF: ASSIST OFF

WALK: WALK ASSIST

↑: SHORT PRESS X
 ↓: SHORT PRESS Y
 →: LONG PRESS Y
 ←: SHORT PRESS X
 (THIS OPERATION IS FOR CANCELING [WALK] MODE)

*The Walk assist mode function may not be able to be used in certain regions.

SWITCHING TO WALK ASSIST MODE

- With your feet off the pedals and current speed at [0 mph], hold down Y until [WALK] displays.
NOTE: A warning tone will sound while switching is in progress if it is not possible to switch to [WALK] mode because the current speed is not [0 mph] or there is pressure on the pedals etc.
- Release Y when (WALK) displays.
- Hold down Y again to activate walk assist. Walk assist remains active provided Y is being held down.
- To cancel (WALK) mode, release Y and press X. When (WALK) mode is canceled, the mode active before (WALK) mode was set, is re-activated.

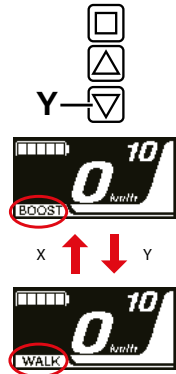

NOTES ON WALK ASSIST MODE

- If Y is not pressed for one minute or more, the mode active before [WALK] mode was set, is re-activated.
- If the bicycle is not moved after [WALK] mode is activated, walk assist is automatically inactivated. To re-activate [WALK] mode, momentarily release Y and then hold down Y.
- The walk assist function can operate at a maximum of 3.7 mph.
- The assistance level and speed vary with the gear position.
- The intelligent walk assist function activates when an electric shifting system such as XTR, DEORE XT SEIS is connected. System individually supplies assist power to detect gear position.
- "Intelligent walk assist" support rider more torque output in steep climb condition in lower side gears.
- "Quick walk assist" function works by holding down SW from any mode.

MAINTENANCE

GENERAL SERVICE AND CARE //

You have purchased a high performance bicycle which requires a certain level of service and maintenance to sustain the level of performance your frame was designed around. Proper care will also ensure the bike is safe to ride at all levels. It is important to read and understand the carbon care information as well as follow the maintenance schedule and inspect your bicycle before each ride. These will not only help to limit or avoid costly repairs but will also help to avoid injury due to service neglect and component failure.

CARBON CARE //

Intense Cycles employs advanced composite techniques and materials in our frames which do require a certain level of care and maintenance to ensure a safe experience at the high level of performance each frame is designed around. Not following these guidelines will decrease the level of performance and possibly cause injury or death.

- Use a soft cloth with warm soapy water to clean the carbon surfaces. Do not use high pressure washers, abrasive cloths or cleaners.
- Be sure all frame surfaces in contact with cables are protected. Cable housing rubbing on carbon can wear over time.
- Be sure brake levers, handle bar ends and the fork crown do not contact the frame at full rotation.
- Never clamp any part of a carbon frame in a bike stand or car rack.
- Always inspect your frame if you experience any chain suck.
- Always inspect your frame in full after a crash to be sure there is no damage. Look for cracks, dents or loose fibers. If you discover damage in any degree it's best to have your frame inspected by a qualified Intense Cycles dealer. Any direct impact to the frame can cause serious structural damage.
- Use high grade waterproof grease on seat post, BB and head set bearing contact areas with the carbon.
- Never ream or face a carbon frame.
- Be sure to follow all recommended torque settings.
- Use only genuine replacement parts for safety-critical components.



MAINTENANCE SCHEDULE* //

| | ACTION | EVERY RIDE | 500 MILES OR 1 MONTH | 2000 MILES OR 6 MONTHS | 4000 MILES OR 1 YEAR |
|------------------|---|------------|----------------------|------------------------|-------------------------|
| TIRES | Check air pressure, inspect tread and sidewalls for tears and punctures | X | | | |
| CHAIN | Brush off and lubricate | X | | | |
| BRAKES | Squeeze brakes and confirm function | X | | | |
| GENERAL | Clean complete bike of mud and debris | | X | | |
| HEADSET | Check adjustment | | X | | |
| BOX LINK | Add grease thru zerk fittings | | X | | |
| FRAME PIVOTS | Check torques | | X | | |
| SPOKES | Inspect for damage, check tension | | X | | |
| SHOCK AND FORK | Check air pressure, inspect for leaks | | X | | |
| DERAILEUR CABLES | Inspect and lube | | | X | |
| SEATPOST | Clean and regrease interface with frame | | | X | |
| FRAME PIVOTS | Remove pivot bolts, check bearings for pitting and wear | | | X | |
| HEADSET | Disassemble stem, headset and fork. Check bearings for pitting and wear | | | X | |
| HUBS | Pull wheels off, check hub bearings for pitting and wear | | | X | |
| BOTTOM BRACKET | Remove crank arms and check BB bearings for pitting and wear | | | X | |
| BRAKES | Replace brake pads | | | X | |
| CHAIN | Inspect for damage and check for stretching | | | X | |
| GENERAL | Complete Tune-Up | | | | X |
| SHOCK AND FORK | Overhaul | | | | See MFG Recommendations |

* The above maintenance schedule is only a guideline. Refer to component manufacturer for specific instruction on maintaining their parts.

TROUBLESHOOTING //

BATTERY LED LAMP ERROR INDICATIONS

System errors and similar warnings are indicated by the battery LED lamps through various lighting patterns.

| ERROR INDICATION TYPE | INDICATION CONDITION | LIGHTING PATTERN *1 | RECOVERY |
|-------------------------------|---|---------------------|--|
| System error | Communication error with the bicycle system | | Make sure that the cable is not loose or improperly connected. If the situation does not improve, contact the place of purchase. |
| Temperature protection | If the temperature exceeds the guaranteed operating range, the battery output is turned off. | | Leave the battery in a cool place away from direct sunlight until the internal temperature of the battery decreases sufficiently. If the situation does not improve, contact the place of purchase. |
| Security authentication error | This is displayed if a genuine drive unit is not connected. This is displayed if any of the cables are disconnected. | | Connect a genuine battery and drive unit. Check the condition of the cables. If the situation does not improve, contact the place of purchase. |
| Charging error | This is displayed if an error occurs during charging. | | Remove the charger from the battery and press the power button. If an error appears contact an agency. |
| Battery malfunction | Electrical failure inside the battery | | Connect the charger to the battery and then remove the charger. Press the power button with only the battery connected. If an error appears with only the battery connected, contact the place of purchase. |

*1 : No light : Lighting up : Blinking

WARNING MESSAGES ON THE CYCLE COMPUTER

This disappears if the error is fixed.



| CODE | DISPLAY PRECONDITIONS | OPERATIONAL RESTRICTION WHEN AN ERROR IS BEING DISPLAYED | REMEDY |
|------|---|---|---|
| W010 | Temperature of the drive unit is higher than it is during times of normal operation. | Power assistance may be lower than usual. | Stop using the assist function until the temperature of the drive unit drops. If the situation does not improve, contact the place of purchase. |
| W011 | The traveling speed cannot be detected. | The maximum speed up to which power assistance is provided may be lower than usual. | Check that the speed sensor is properly installed. If the situation does not improve, contact the place of purchase. |
| W013 | Initialization of torque sensor was not completed successfully. | Power assistance may be lower than usual. | With your foot off the pedal, press the battery power button and turn on the power again. If the situation does not improve, contact the place of purchase. |
| W032 | An electronic derailleur may have been installed in place of a mechanical derailleur. | Power assistance provided in [WALK] mode may be lower than usual. The walk assist mode function may not be able to be used in certain regions. | Reinstall the derailleur for which the system is configured to support. If the situation does not improve, contact the place of purchase. |

REFERENCE //

Shimano Steps E8000 User Manual: <http://si.shimano.com/pdfs/um/UM-72F0A-006-00-ENG.pdf>

INTENSE TAZER MANUAL //

DECLARATION OF CONFORMITY



THE MANUFACTURER

INTENSE CYCLES

42380 Rio Nedo

Temecula, CA 92590-3708, USA

TEL: 1.951.296.9596

HEREBY CONFIRMS THE FOLLOWING PRODUCTS:

Product Name: INTENSE TAZER e-Bike

Year of Construction: 2018 / 2019

Conformity with all applicable provisions from the Machinery Directive (2006/42/EC).

The machine conforms to all applicable provisions of the Directive 2014/30/EU Electromagnetic Compatibility Directive.

These standards were applied:

EN 15194 / 2017 Bicycles:

Electrically power assisted bicycles, EPAC Bicycles.

ISO 4210-2 Bicycles: Safety requirements for bicycles.

Technical documentation from:

INTENSE CYCLES

42380 Rio Nedo

Temecula, CA 92590-3708, USA

TEL: 1.951.296.9596

Place and Date of issue of this

Declaration of Conformity:

Temecula, CA, August 15, 2018.

Jeff Steber

CEO/ Founder

Chad Peterson

COO/ Product Manager

Chris Knutson

Engineer



MAXXIS

TAZER

52%
SUNSHINE

DECEP XT

TAZER

DT

WWW.INTENSECYCLES.COM

PHONE:

+1[951]-307-9211

CUSTOMER SERVICE:

TECHCENTER@INTENSECYCLES.COM

GENERAL INFO:

INFO@INTENSECYCLES.COM

MEDIA, MARKETING, SPONSORSHIP:

MARKETING@INTENSECYCLES.COM

INTENSE CYCLES USA 42380 RIO NEDO TEMECULA, CA. 92590