



INTENSE
CYCLES . USA

USER MANUAL | RECLUSE

WELCOME TO THE FAMILY

AT INTENSE WE HAVE ONE GOAL - TO PROVIDE THE RIDE OF YOUR LIFE //

Our team of designers, engineers and product experts are focused on one thing every day: your experience on the bike. We build bikes that are as thrilling to look at as they are to ride, and we build them for the select few of you who understand the difference and refuse to settle for anything else.

From the early days of Intense, when founder Jeff Steber worked alone in his garage to today, where a crew of talented people work in a Temecula, CA factory, Intense has been a brand built on passion by forward thinkers who, even today, love nothing more than to throw a leg over a sweet bike and head out for a rip. We're so glad you've joined us.

Welcome to Intense, enjoy your experience.

THE RECLUSE //

Introducing the Recluse, an All Mountain ride with 140mm of rear wheel travel. This full carbon monocoque chassis is built with the strength and stiffness needed for all mountain riding but maintains the comfort and forgiveness for those longer trail rides. It's equipped with Flak Guard Armor, grease zerks for easy maintenance and a whole lot of attitude that will keep you alone, out in front of the pack.

REGISTRATION

WWW.INTENSECYCLES.COM/WARRANTY-CARD/



CONTACT CUSTOMER SERVICE

CS@INTENSECYCLES.COM

951-296-9596



INTRODUCTION / REGISTRATION 2

FRAME FEATURES / COMPONENT SPEC 4

GEOMETRY 5

EXPLODED VIEW AND B.O.M. 6

ASSEMBLY 8

TORQUE CHART 13

SETUP 14

MAINTENANCE 18

FRAME FEATURES / SPEC

FRAME FEATURES //

- TRAVEL: 5.5" [140MM]
- 27.5" WHEEL SIZE
- INTEGRATED BOOST 148 X 12 DROPOUTS
- 5.98 LBS / 2.715 GRAMS = STANDARD FRAME W/ ALLOY LINK, NO SHOCK
- 5.55 LBS / 2.520 GRAMS = SL SUPER LIGHT FRAME W/ ALLOY LINK, TITANIUM HARDWARE, NO SHOCK
- INTERNAL CABLE ROUTING
- INTERNAL SEAT TUBE CABLE ROUTING FOR DROPPER POSTS
- MONOCOQUE FRONT TRIANGLE
- H2O BOTTLE FITMENT
- FLACK GAURD DOWNTUBE AND CHAINSTAY PROTECTION
- TAPERED HEAD TUBE
- DIRECT MOUNT FRONT DERAILLEUR
- ANGULAR CONTACT/COLLET BEARING SYSTEM WITH REPLACEABLE GREASE ZERKS

COMPONENT SPEC //

- FORK – 1.5" TAPERED STEER, 150MM TRAVEL, 542MM LOWER LEG LENGTH, 42MM OFFSET
- SHOCK – 200MM X 57.15MM (7.875" X 2.25"), 22MM X 6MM AND 30MM X 6MM REDUCERS
- FRONT DERAILLEUR – DIRECT MOUNT
- SEAT POST – 31.6MM
- HEADSET – CANE CREEK, 40, ALLOY CARTRIDGE (WWW.CANECREEK.COM)
- BOTTOM BRACKET – PF92
- REAR AXLE – BOOST 148 X 12 T/A
- BRAKE MOUNT – INTERNATIONAL STANDARD FOR 160MM ROTOR
- CRANK SET – BOOST 148 COMPATIBLE - SINGLE OR DOUBLE RING ONLY
- REAR WHEEL – BOOST 148 COMPATIBLE

GEOMETRY

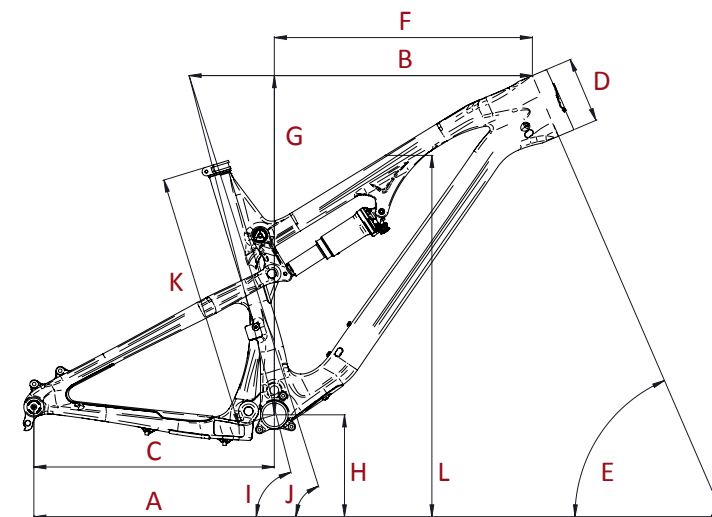

		SMALL	MEDIUM	LARGE	XLARGE
A	Wheel Base:	1142 mm/ 45"	1169 mm/ 46"	1196 mm/ 47"	1222 mm/ 48"
B	Top Tube Length:	575 mm/ 22.6"	601 mm/ 23.6"	626 mm/ 24.6"	652 mm/ 25.6"
C	Chain Stay Length:	419 mm/ 16.5"	419 mm/ 16.5"	419 mm/ 16.5"	419 mm/ 16.5"
D	Head Tube Length:	102 mm/ 4"	115 mm/ 4.5"	127 mm/ 5"	127 mm/ 5"
E	Head Tube Angle:	66°	66°	66°	66°
F	Reach:	417 mm/ 16.4"	438 mm/ 17.3"	460 mm/ 18.1"	486 mm/ 19.2"
G	Stack:	587 mm/ 23.1"	599 mm / 23.6"	611 mm/ 24"	611 mm/ 24"
H	BB Height:	344 mm/ 13.5"	344 mm/ 13.5"	344 mm/ 13.5"	344 mm/ 13.5"
I	Seat Tube Angle (Effective):	75°	75°	75°	75°
J	Seat Tube Angle (Actual):	72°	72°	72°	72°
K	Seat Tube Length:	376 mm/ 14.8"	446 mm/ 17.6"	484 mm/ 19"	515 mm/ 20.3"
L	Standover Height:	792 mm/ 31.2"	800 mm/ 31.5"	807 mm/ 31.8"	807 mm/ 31.8"

GEOMETRY NOTES

GEOMETRY TAKEN AT TOP OUT WITH 542MM FORK LENGTH AND 42MM FORK OFFSET.

COMPONENT SPEC NOTE

THE RECLUSE IS DESIGNED AROUND THE USE OF SINGLE OR DOUBLE CHAIN RING SETS ONLY. USE OF A TRIPLE RING SET WILL NOT ALLOW PROPER CLEARANCE WITH THE FRAME.

EXPLODED VIEW AND B.O.M.

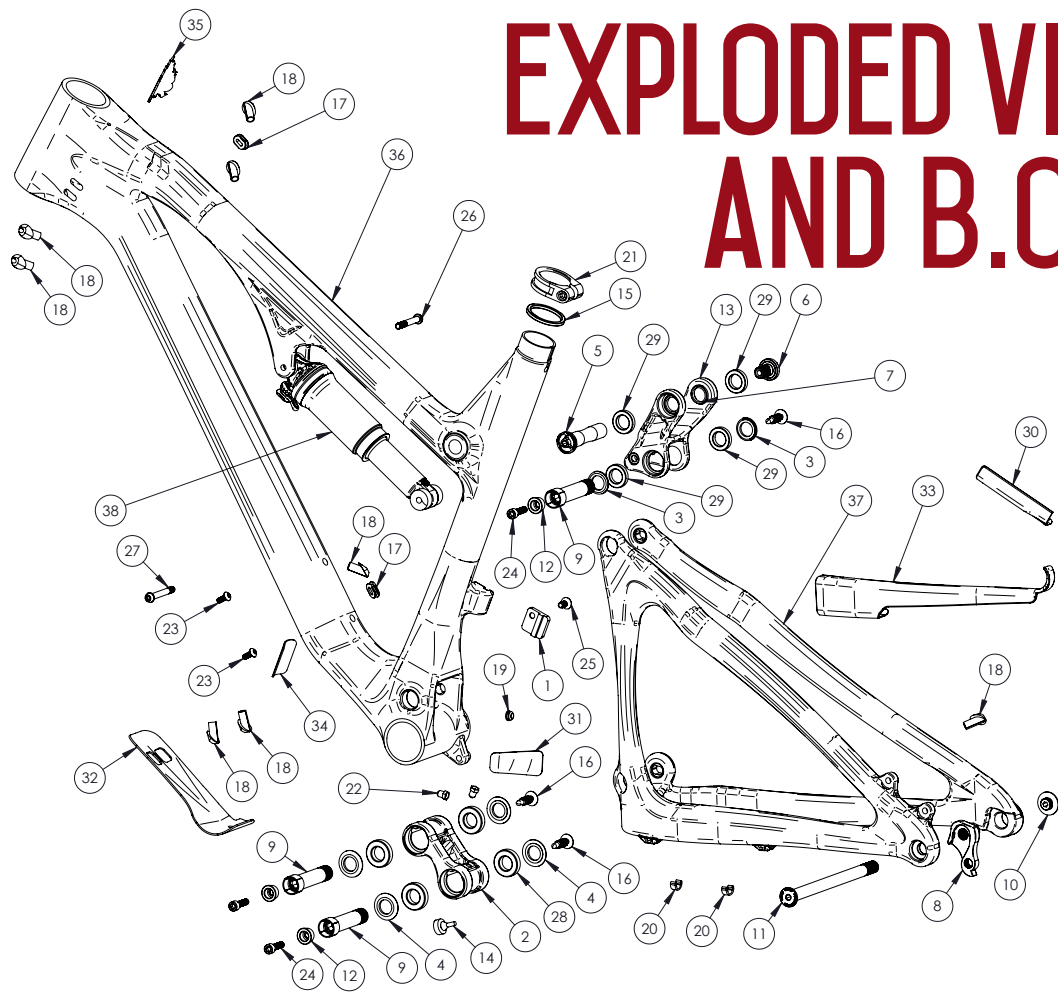

ITEM NO.	ITEM	PART NUMBER	DESCRIPTION	QTY.	TORQUE SPEC.
1	Derailleur Mount Cover	130209	For Single Ring Setup	1	N/A
2	Box Link	130764	Forged Lower Link	1	N/A
3	Bearing Cap 24mm OD	130765	Top Link Bearing Spacer (Lower)	2	N/A
4	Bearing Cap	130778	Box Link Bearing Cap	4	N/A
5	Axle Upper	130780	Top Link Pivot Axle (Upper)	1	20 Nm / 175 in-lbs
6	Bolt Shoulder	130785	Top Link Pivot Bolt	1	20 Nm / 175 in-lbs
7	Spacer	130789	Top Link Bearing Spacer (Upper)	2	N/A
8	Hanger	130790	Derailleur Hanger Forged	1	N/A
9	Bolt Main Pivot	130791	Box Link Expander Bolt	3	7 Nm / 60 in-lbs
10	Hanger Bolt	130792	Derailleur Hanger Bolt	1	11 Nm / 100 in-lbs
11	Rear Axle	130799	Axle 148 x 12 Boost	1	11 Nm / 100 in-lbs
12	Cone Adjuster	130807	Cone Adjuster Blk, 8.3 mm Height	3	N/A
14	Bumper	140006	Box Link Bumper	1	N/A
15	O-Ring	140013	Seat Clamp o-ring	1	N/A
16	Plug	140038	Box Link Pivot Plug	3	N/A
17	Cable Guide Grommet	140039	Cable Guide Grommet (Head Tube)	2	N/A
18	Cable Guide Plug	140040	Cable Guide Plug (Thru)	8	N/A
19	Cable Guide Grommet	140042	Cable Guide Grommet (Rear Triangle)	1	N/A
20	Clip	310001	Cable Guide Clip	2	N/A
21	Seat Collar	346941	Bolt-on 36.1 Blk	1	N/A

ITEM NO.	ITEM	PART NUMBER	DESCRIPTION	QTY.	TORQUE SPEC.
22	Zerk Fitting	401011	M6 x 1.0	2	5 Nm / 40 in-lbs
23	BHCS M5 X 12	410010	Water Bottle Bolt, Button Head, M5 X 12	2	6 Nm / 54 in-lbs
24	SHCS M6 x 22	410032	Cone Adjuster Bolt, Socket Head, M6 x 22 Titanium	3	14 Nm / 125 in-lbs
24ST	SHCS M6 x 22	410009	Cone Adjuster Bolt, Socket Head, M6 x 22 Stainless Steel	3	14 Nm / 125 in-lbs
25	FHCS M6 x 12	410037	Front Derailleur Mount Bolt, Flat Head, M6 x 12 Blk	1	7 Nm / 60 in-lbs
26	SHCS M6 x 40	410050	Front Shock Bolt, Socket Head, M6 x 40 Titanium	1	7 Nm / 60 in-lbs
26ST	SHCS M6 x 40	410053	Front Shock Bolt, Socket Head, M6 x 40 Stainless Steel	1	7 Nm / 60 in-lbs
27	SHCS M6 x 45	410051	Rear Shock Bolt, Socket Head, M6 x 45 Titanium	1	7 Nm / 60 in-lbs
27ST	SHCS M6 x 45	410054	Rear Shock Bolt, Socket Head, M6 x 45 Stainless Steel	1	7 Nm / 60 in-lbs
28	Bearing 7902	430007	15 x 28 x 7 2RS MAX Angular Contact Bearing	4	N/A
29	Bearing 6802	430008	15 x 24 x 5 2RS MAX Radial Bearing	4	N/A
30	Guard Flack SS	500254	Flack Guard Seatstay	1	N/A
31	Protector Chainstay	500255	Protector Chainstay	1	N/A
32	Guard Flack DT	500256	Flack Guard Down Tube	1	N/A
33	Guard Flack CS	500259	Flack Guard Chainstay	1	N/A
34	Decal	500300	Decal California Bear	1	N/A
35	Head Badge	500335	Head Badge Flame Logo	1	N/A
36	Front Triangle		Carbon - 4 Sizes	1	N/A
37	Rear Triangle		Carbon - 1 Size	1	N/A
38	Rear Shock	Shock	7875in x 2.25in (200mm x 57mm)	1	N/A

ASSEMBLY

PREFACE //

Service and maintenance on an Intense bicycle requires special tools, abilities and knowledge of working on bicycles. It is always recommended to use an authorized Intense dealer for service and maintenance. Always wear eye protection. It is critical to use the proper tools, loctite, grease and torque specs during assembly. Failure to follow these instructions may result in serious bodily injury or death.

TOOLS NEEDED

- HIGH GRADE, WATERPROOF GREASE (MAXIMA WATERPROOF GREASE RECOMMENDED)
- BLUE LOCTITE® #243
- 5MM HEX WRENCH X2
- 8MM HEX WRENCH

RECOMMENDATION

USE GREASE ON LOWER LINKAGE BOLTS ONLY. USE LOCTITE ON UPPER LINKAGE BOLTS, DROPOUT BOLTS AND HANGER BOLT.

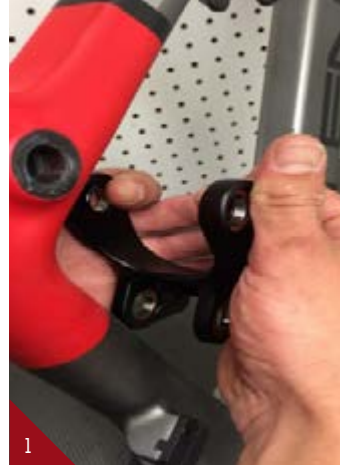

1



2

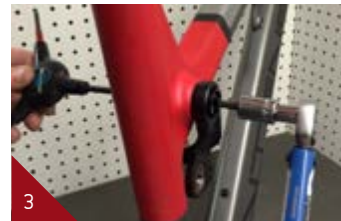

3



4



5

CONNECTING TOP LINK TO FRONT TRIANGLE //

A Holding top link (#130808) with shock mount pointed forward, hold upper spacer (#130789) against inside of bearing race (IMAGE #1).

B Match upper link to top tube, making sure that spacers do not fall out.

C Using upper pivot axle (#130780), insert through non-drive side of top link bearing and push through to drive side bearing, making sure spacers do not fall out (IMAGE #2). Install shoulder bolt (#130785) into drive side of top link pivot, and tighten to 20 NM or 175 in/lbs (IMAGE #3).

CONNECTING BOX LINK TO FRONT TRIANGLE //

A Hold bearing caps (#130778) with rounded ends facing outwards against bearings on box link (#130764), (note box link orientation (IMAGE #4), with rubber bumper facing upward and rearward on box link).

B Match link to front triangle and from non drive side, insert greased main pivot bolt (#130791) through the non-drive side of frame (IMAGE #5).

C Use 8mm HEX to install, then torque pivot bolt (#130791) to 7 NM or 60 in/lbs.



6



7



8



9



10



11

CONNECTING REAR TRIANGLE TO BOX LINK //

A Follow previous step to connect rear triangle to box link (IMAGE #6).

B Use 8mm HEX to install, then torque pivot bolt (#130791) to 7 NM or 60 in/lbs (IMAGES #7 & 8).

CONNECTING REAR TRIANGLE TO TOP LINK //

A Holding bearing cap (#130765) with squared edges against the bearing and the rounded side facing outward (IMAGE #9), Swing the seat stays up and align with the lower spacers. From the non drive side of top link insert greased main pivot bolt (#130791) through the non-drive side of frame (IMAGES #9 & 10).

B Use an 8mm HEX to install torque main pivot bolt (#130791) to 7 NM or 60 in/lbs (IMAGE #11).



12



13



14



15

INSTALLING REAR SHOCK //

A Holding rear shock match forward end to forward shock mount, and install greased M6x40mm bolt (#410050) through drive side of frame (IMAGE #12). Do not tighten.

B Match rear end of shock to upper link and install greased M6x45mm bolt (#400051) through non-drive side of link (IMAGE #13).

C Torque shock bolts (#410050 & #400051) to 7 NM or 60 in/lbs (IMAGES #14 & 15).



16



17



18

TIGHTENING SEATSTAYS TO TOP LINK //

A Grease and install adjuster cone (#130807) into head of main pivot bolt (#130791) and greased M6x22mm bolt (#410032) through the adjuster cone into the main pivot bolt (IMAGE #16).

B Using hand pressure, squeeze the top of seat stay together at the lower top link location to eliminate side to side play (IMAGE #17) then use a 5mm HEX to make snug.

C Torque M6x22mm (#410032) to 14 NM or 125 in/lbs (IMAGE #18).

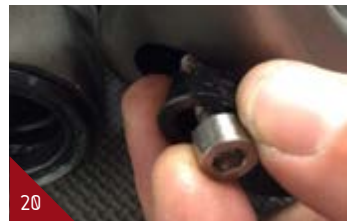

INSTALLING ADJUSTER CONES ON LOWER LINK //

A Grease and install adjuster cone (#130807) into head of main pivot bolt (#130791) and greased M6x22mm bolt (#410032) through the adjuster cone into the main pivot bolt (IMAGES #19 & 20).

B Torque M6x22mm (#410032) to 14 NM or 125 in/lbs (IMAGE #21).

INSTALLING DERAILLEUR HANGER //

A Grease outer edges of derailleur hanger (#130790) and loctite derailleur bolt (#130792) if not pre loctite applied.

B Insert hanger (#130790) into back of frame opening and match derailleur bolt (#130792) on the front side threading bolt into hanger (IMAGE #22 & 23).

C Torque derailleur bolt (#130792) to 11 NM or 100 in/lbs (IMAGE #24).

TORQUE CHART

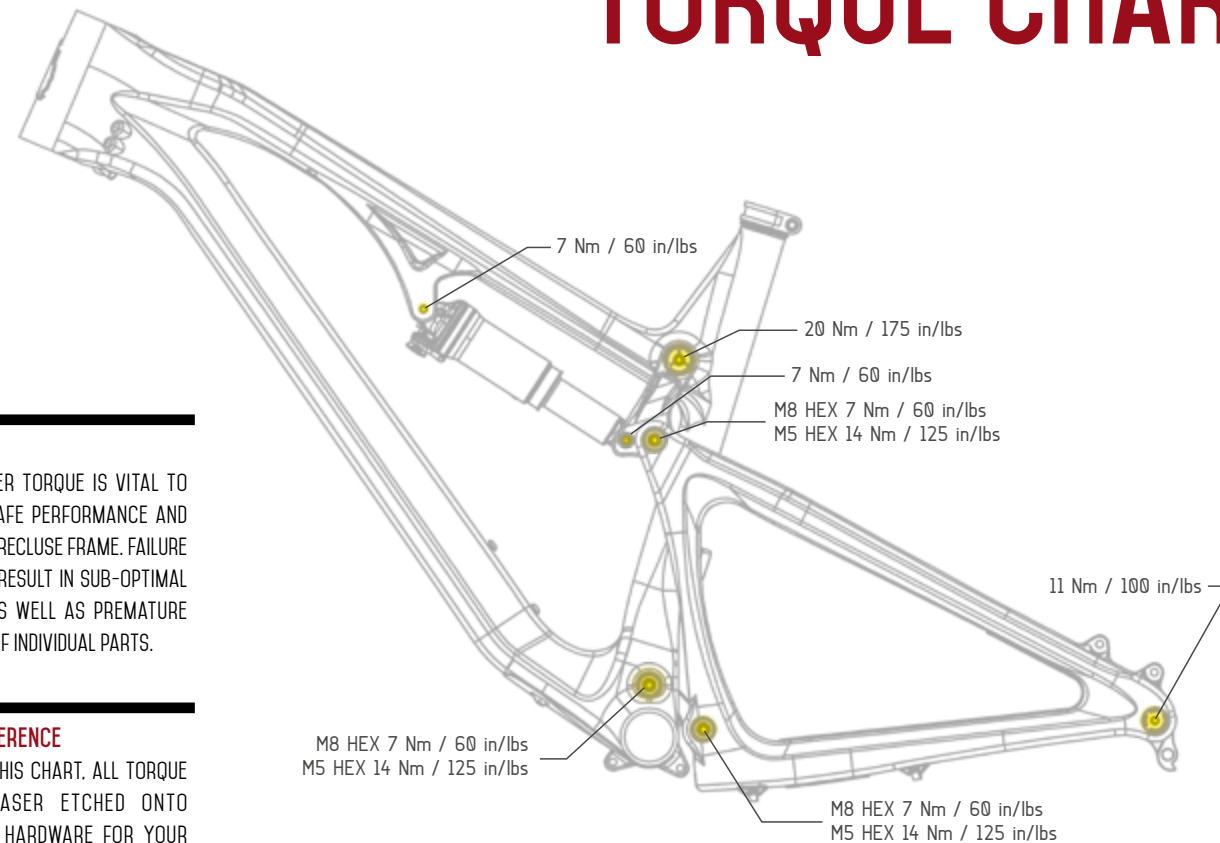

TORQUE

ACHIEVING PROPER TORQUE IS VITAL TO ENSURING THE SAFE PERFORMANCE AND FUNCTION OF THE RECLUSE FRAME. FAILURE TO DO SO COULD RESULT IN SUB-OPTIMAL PERFORMANCE AS WELL AS PREMATURE WEAR AND TEAR OF INDIVIDUAL PARTS.

ADDITIONAL REFERENCE

IN ADDITION TO THIS CHART, ALL TORQUE VALUES ARE LASER ETCHED ONTO CORRESPONDING HARDWARE FOR YOUR REFERENCE.



SET UP

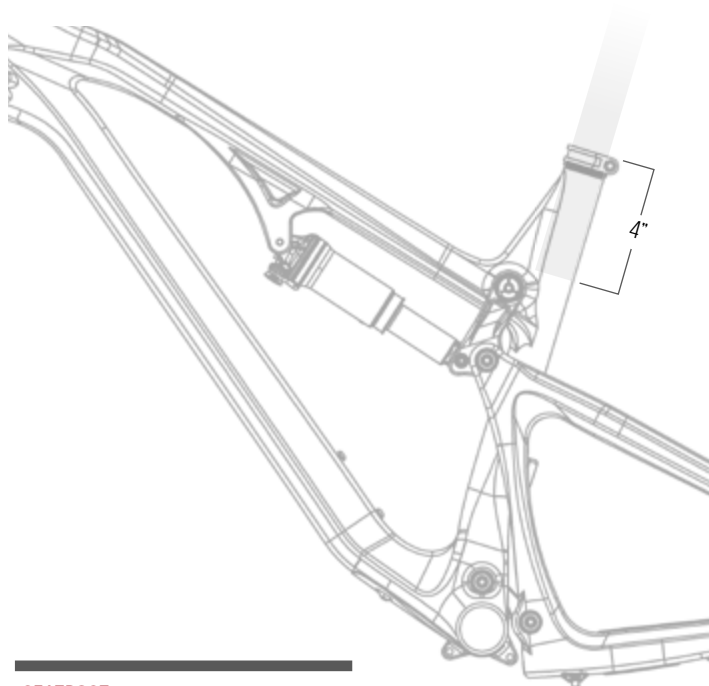

SEATPOST

MAKE SURE TO INSERT SEAT POST AT LEAST 4" INTO THE MAIN FRAME. ANYTHING LESS THAN THIS AMOUNT COULD CAUSE DAMAGE TO THE FRAME OR EVEN FAILURE.

SHOCK SETUP

ROCK SHOX MONARCH RC3 / R 200 X 57MM



SET UP AND TUNE

PROPER SET UP AND TUNING CAN VARY FROM SHOCK TO SHOCK. PLEASE CONSULT THE ROCKSHOX MANUAL INCLUDED WITH YOUR BIKE FOR COMPLETE INFORMATION ABOUT SET UP, TUNING AND GENERAL MAINTENANCE OR VISIT WWW.SRAM.COM/ROCKSHOX/PRODUCTS

TRAVEL	140 MM	
SHOCK STROKE	57 mm	
SHOCK SAG	20% when sitting on the bike	
FORK SAG	25-30% when sitting on the bike	
SHOCK: RECLUSE 275 EXPERT	Rock Shox Monarch RC3 200x57 mm DB2 MM S 320	
SHOCK: RECLUSE 275 FOUNDATION	Rock Shox Monarch R 200x57 mm DB2 MM S 320	
RIDER WEIGHT (LBS/KGS)	SPRING (PSI)	REBOUND (CLICKS OUT)
100 LBS / 45 KGS	80	2 to 3
110 LBS / 50 KGS	88	
120 LBS / 54 KGS	97	
130 LBS / 59 KGS	105	
140 LBS / 63.5 KGS	114	
150 LBS / 68 KGS	122	3 to 4
160 LBS / 73 KGS	131	
170 LBS / 77 KGS	139	
180 LBS / 82 KGS	148	
190 LBS / 86 KGS	156	
200 LBS / 91 KGS	164	
210 LBS / 95 KGS	173	
220 LBS / 100 KGS	181	5 to 6
230 LBS / 104 KGS	190	
240 LBS / 109 KGS	198	
250 LBS / 113 KGS	207	
260 LBS / 118 KGS	215	
270 LBS / 122 KGS	224	
280 LBS / 127 KGS	232	
290 LBS / 131.5 KGS	241	
300 LBS / 136 KGS	249	

SHOCK SETUP

FOX FLOAT X2 200 X 57MM



SET UP AND TUNE

PROPER SET UP AND TUNING CAN VARY FROM SHOCK TO SHOCK. PLEASE CONSULT THE FOX MANUAL INCLUDED WITH YOUR BIKE FOR COMPLETE INFORMATION ABOUT SET UP, TUNING AND GENERAL MAINTENANCE OR VISIT WWW.FOXRACINGSHOX.COM

TRAVEL	140 MM
SHOCK STROKE	57 mm
SHOCK SAG	20% when sitting on the bike
FORK SAG	25-30% when sitting on the bike
SHOCK: RECLUSE 275 FACTORY	FOX Shox, FLOAT X2, F-S, K, 2POS Lever, 200x57 mm
SHOCK: RECLUSE 275 PRO	FOX Shox, FLOAT X2, P-SE, A, 2POS Lever, 200x57 mm
RIDER WEIGHT(LBS/KGS)	SPRING (PSI)
100 LBS / 45 KGS	100
110 LBS / 50 KGS	111
120 LBS / 54 KGS	121
130 LBS / 59 KGS	132
140 LBS / 63.5 KGS	142
150 LBS / 68 KGS	152
160 LBS / 73 KGS	163
170 LBS / 77 KGS	173
180 LBS / 82 KGS	184
190 LBS / 86 KGS	194
200 LBS / 91 KGS	204
210 LBS / 95 KGS	215
220 LBS / 100 KGS	225
230 LBS / 104 KGS	235
240 LBS / 109 KGS	246
250 LBS / 113 KGS	256
260 LBS / 118 KGS	267
270 LBS / 122 KGS	277
280 LBS / 127 KGS	287
290 LBS / 131.5 KGS	298
300 LBS / 136 KGS	308



MAINTENANCE

GENERAL SERVICE AND CARE //

You have purchased a high performance bicycle which requires a certain level of service and maintenance to sustain the level of performance your frame was designed around. Proper care will also ensure the bike is safe to ride at all levels. It is important to read and understand the carbon care information as well as follow the maintenance schedule and inspect your bicycle before each ride. These will not only help to limit or avoid costly repairs but will also help to avoid injury due to service neglect and component failure.

CARBON CARE

INTENSE CYCLES EMPLOYS ADVANCED COMPOSITE TECHNIQUES AND MATERIALS IN OUR FRAMES WHICH DO REQUIRE A CERTAIN LEVEL OF CARE AND MAINTENANCE TO ENSURE A SAFE EXPERIENCE AT THE HIGH LEVEL OF PERFORMANCE EACH FRAME IS DESIGNED AROUND. NOT FOLLOWING THESE GUIDELINES WILL DECREASE THE LEVEL OF PERFORMANCE AND POSSIBLY CAUSE INJURY OR DEATH.

- Use a soft cloth with warm soapy water to clean the carbon surfaces. Do not use abrasive cloths or cleaners.
- Be sure all frame surfaces in contact with cables are protected. Cable housing rubbing on carbon can wear over time.
- Be sure brake levers, handle bar ends and the fork crown do not contact the frame at full rotation.
- Never clamp any part of a carbon frame in a bike stand or car rack.
- Always inspect your frame if you experience any chain suck. Intense frames come equipped with steel chain suck plates but damage can still be done in the event of chain suck.
- Always inspect your frame in full after a crash to be sure there is no damage. Look for cracks, dents or loose fibers. If you discover damage in any degree it's best to have your frame inspected by a qualified Intense Cycles dealer. Any direct impact to the frame can cause serious structural damage.
- Use high grade waterproof grease on seat post, BB and head set bearing contact areas with the carbon.
- Never ream or face a carbon frame.
- Be sure to follow all recommended torque settings.



MAINTENANCE SCHEDULE *

ACTION		EVERY RIDE	500 MILES OR 1 MONTH	2000 MILES OR 6 MONTHS	4000 MILES OR 1 YEAR
TIRES	Check air pressure, inspect tread and sidewalls for tears and punctures	X			
CHAIN	Brush off and lubricate	X			
BRAKES	Squeeze brakes and confirm function	X			
GENERAL	Clean complete bike of mud and debris		X		
HEADSET	Check adjustment		X		
BOX LINK	Add grease thru zerk fittings		X		
FRAME PIVOTS	Check torques		X		
SPOKES	Inspect for damage, check tension		X		
SHOCK AND FORK	Check air pressure, inspect for leaks		X		
DERAILEUR CABLES	Inspect and lube			X	
SEATPOST	Clean and regrease interface with frame			X	
FRAME PIVOTS	Remove pivot bolts, check bearings for pitting and wear			X	
HEADSET	Disassemble stem, headset and fork. Check bearings for pitting and wear			X	
HUBS	Pull wheels off, check hub bearings for pitting and wear			X	
BOTTOM BRACKET	Remove crank arms and check BB bearings for pitting and wear			X	
BRAKES	Replace brake pads			X	
CHAIN	Inspect for damage and check for stretching			X	
GENERAL	Complete Tune-Up				X
SHOCK AND FORK	Overhaul			See MFG Recommendations	

* THE ABOVE MAINTENANCE SCHEDULE IS ONLY A GUIDELINE. REFER TO COMPONENT MANUFACTURER FOR SPECIFIC INSTRUCTION ON MAINTAINING THEIR PARTS.

W W W . I N T E N S E C Y C L E S . C O M

PHONE: (951)-296-9596

CUSTOMER SERVICE: CS@INTENSECYCLES.COM

GENERAL INFO: INFO@INTENSECYCLES.COM

MEDIA, MARKETING, SPONSORSHIP: MARKETING@INTENSECYCLES.COM

INTENSE CYCLES USA 42380 RIO NEDO TEMECULA, CA. 92590