

INTENSE

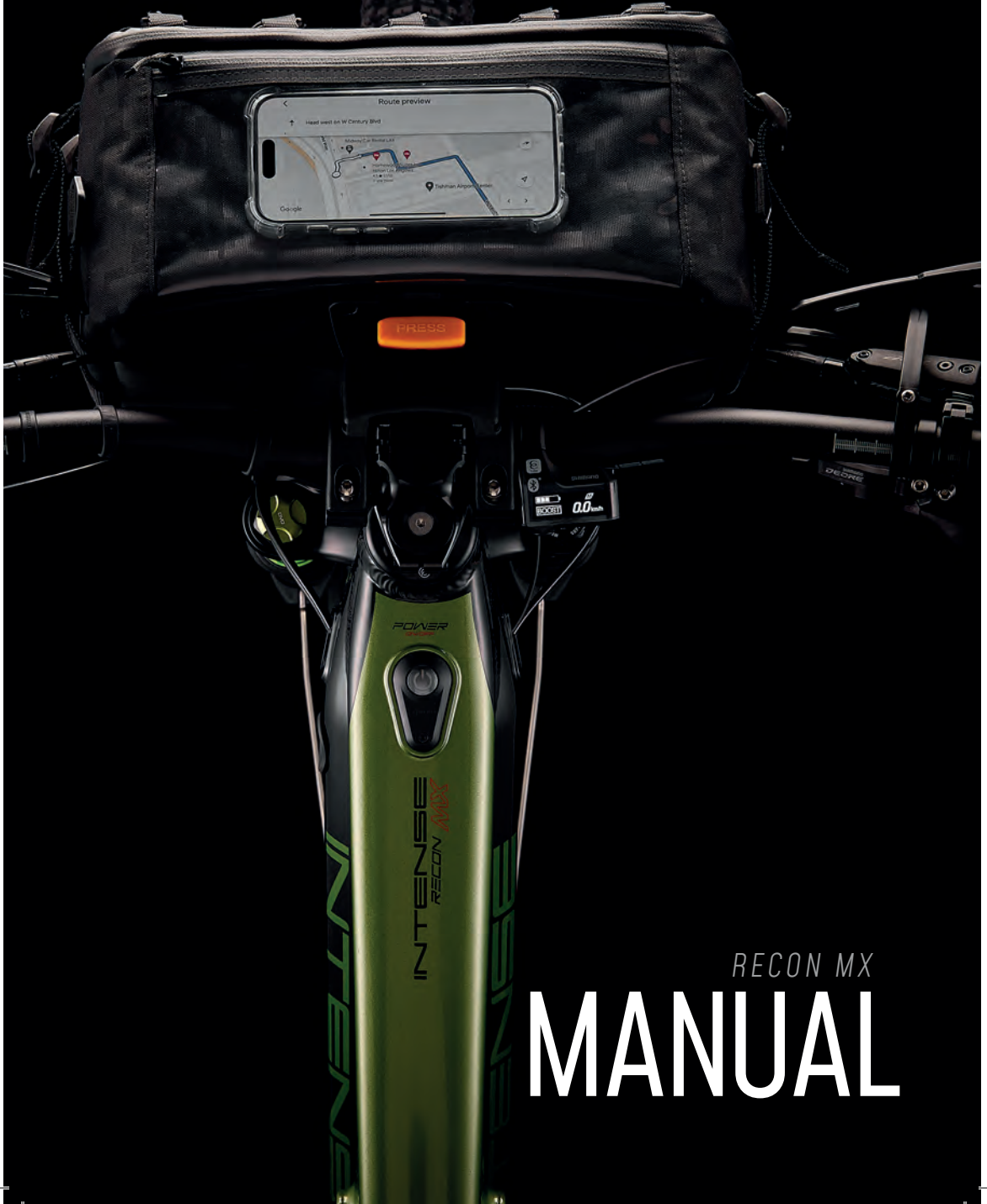

RECON MX

# MANUAL

REGISTER YOUR BIKE

Don't forget to register your bike:

[www.intensecycles.com/pages/registerbike](http://www.intensecycles.com/pages/registerbike)

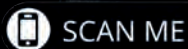

TECHNICAL ASSISTANCE

We are here to help. If you need any technical assistance, please contact us:

[techcenter@intensecycles.com](mailto:techcenter@intensecycles.com)

US: 951-307-9211

# CONTENTS

<b>02</b>	<b>Register your Bike information</b>	<b>46</b>	<b>INTENSE bicycle identification</b>
<b>05</b>	<b>Welcome to INTENSE</b>		
<b>06</b>	<b>Know your Recon MX</b>	<b>48</b>	<b>How to use your Recon MX</b>
<b>09</b>	<b>Set-up guide</b>		
11	<i>Remove bike from box</i>	48	<i>Charging the battery</i>
13	<i>Charge the battery</i>	51	<i>Turning on your Recon MX</i>
15	<i>Install the rear derailleur and handlebar</i>	52	<i>Using the power modes</i>
17	<i>Connecting the motor mode selector and display wires</i>	56	<i>The display</i>
19	<i>Install front fender</i>	58	<i>SHIMANO E-Tube app</i>
21	<i>Install front wheel</i>	60	<i>Troubleshooting</i>
23	<i>Install pedals</i>	<b>64</b>	<b>Maintenance and care</b>
23	<i>Check gears</i>	<b>66</b>	<b>Component listings</b>
25	<i>Adjust headset, handlebars and saddle height,</i>	<b>67</b>	<b>Geometry chart</b>
27	<i>Check tire pressure and install bottle cage, install handguards</i>	<b>68</b>	<b>Exploded views and parts listings</b>
29	<i>Install Handlebar bag</i>	<b>72</b>	<b>Parts kits</b>
31	<i>Install rear pannier bags and bungee cover</i>	<b>76</b>	<b>Torque settings</b>
35	<i>Install battery</i>	<b>78</b>	<b>Declaration of Conformity</b>
37	<i>Front suspension set-up</i>		
42	<i>Rear suspension set-up</i>		





WELCOME TO THE FAMILY

## **AT INTENSE WE HAVE ONE GOAL - TO PROVIDE THE RIDE OF YOUR LIFE**

Our team of designers, engineers and product experts are focused on one thing every day: your experience on the bike. We build bikes that are as thrilling to look at as they are to ride, and we build them for the select few of you who understand the difference and refuse to settle for anything else.

From the early days of INTENSE, when founder Jeff Steber worked alone in his garage, to today with our crew of talented people working in our Temecula, CA headquarters and in offices around the world, INTENSE has been a brand built on passion by forward thinkers who love nothing more than to throw a leg over a sweet bike and head out for a rip. We're so glad you've joined us. Welcome to INTENSE, enjoy your experience.

## **THE INTENSE RECON MX**

Inspired by adventure, the Recon MX is unlike any other eBike you've ridden. Built on 27.5" wheels and with a custom rack and bag set this bike is ready for the ultimate adventure.

**#NOSHUTTLEREQUIRED**



KNOW YOUR RECON MX ALLOY

# COMPONENT BREAKDOWN

- 1 Grips**
- 2 Handguards**
- 3 Shifter**
- 4 Digital display panel**
- 5 Handlebars**
- 6 Front bag mount**
- 7 Stem**
- 8 Front Light**
- 9 Dropper post lever**
- 10 Brake Lever**
- 11 On/Off Button**
- 12 Frame**
  - 1 Toptube*
  - 2 Downtube*
  - 3 Seattube*
  - 4 Chainstay*
  - 5 Seatstay*
  - 6 Rear shock*
- 13 Saddle (seat)**
- 14 Dropper seatpost**
- 15 Seatpost clamp**
- 16 Rear Bags**
- 17 Rear Luggage mounts**
- 18 Cassette**
- 19 Kickstand**
- 20 Rear derailleur**
- 21 Chain**
- 22 Chainring**
- 23 Crankset**
- 24 Front bag**
- 25 Headset**
- 26 Suspension fork**
  - A Fork crown*
  - B Stanchion*
  - C Lower leg*
- 27 Front Fender**
- 28 Front brake**
- 29 Rotor**
- 30 Spoke**
- 31 Tire**
- 32 Thru axle**
- 33 Rim**
- 34 Motor**





*INTENSE RECON MX*

## **SET-UP GUIDE**

Your new INTENSE Recon MX eBike is almost ready to go, you just need to do a few things to get your bike ready for its first ride. If you are setting up your bike from the box, the next few pages will show you how to assemble it. If you picked up your bike already set-up by a dealer then you can jump to page 36.

We have a series of in-depth and detailed videos on our website that go through the whole process of building and preparing your bike – including technical videos on suspension set-up, tuning your gears, and much more.

**GO TO [INTENSE.COM/PAGES/TECHVIDEOS](https://www.intense.com/pages/techvideos)**



### ***WE ARE HERE TO HELP!***

If at any time you feel unsure about what you are doing then please contact us at INTENSE or seek the help of a professional mechanic at your local bike shop.

*INTENSE +1 951.307.9211*

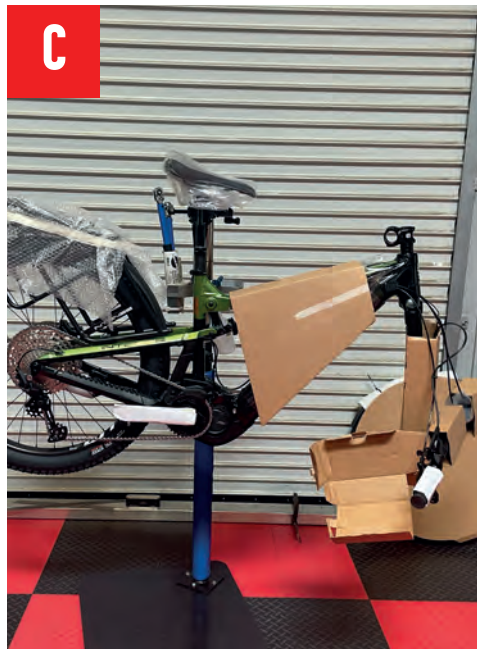

## STEP 1

**REMOVE BIKE  
FROM BOX**

When you first open your bike box you will find the accessory box (including toolkit), battery charger and bike itself (battery is already installed in the bike). First, remove the front wheel and the accessory boxes and put to the side **(A)**.

Next remove, the two rear bags and front handlebar bag as well as second box and set aside. Take off the packaging around the handlebars and expose the dropper post lever on the left-hand side of the handlebar. Push dropper post lever **(B)**. This will raise dropper post to its highest position, which will allow you to put the bike safely in a bike stand **(C)**.

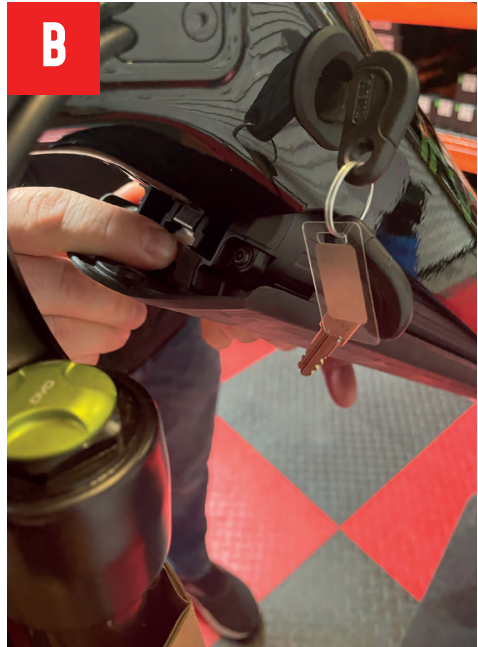
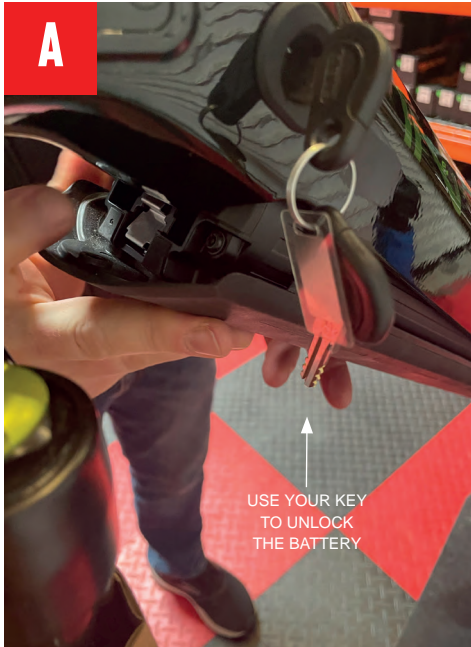



## STEP 2

**CHARGE  
BATTERY**

Once bike is in bike stand, remove remaining packaging. The battery is supplied in sleep mode. To wake it up you need to connect it to your battery charger. You can do this with the battery in your bike by plugging the charger into the port located above the motor near the lower link. It may take up to 10 hours to fully charge the 504 Wh battery. See page 48 for further battery charging information.

If you need to remove your battery from the bike, you will need to use the key provided in the accessory box following the steps below. The lock for the battery is positioned on the upper part of the downtube on the lefthand side of the bike.

With one hand supporting the battery, insert the battery key into the lock **(A)** and turn the key a quarter turn in a clockwise direction. This will release the battery from the lock position and onto the catch-tab.

Now with the battery on the catch-tab, press the release button **(B)** until the battery clears the downtube and pull battery forward and out. Your battery will now be free from your bike.

Remove the key and keep it in a safe place. You can now charge the battery, see page 48 for further information.

It's easiest to charge the battery while it's in the bike. There is a port on the bike above the motor near the lower link **(C)**.



## STEP 3

**CHECK REAR DERAILLEUR**

The rear wheel comes installed on the Recon MX so all you need to do is check the torque on the rear wheel axle. Using your 5mm allen on your torque wrench tighten the rear axle and torque to 11Nm **(A)**.

## STEP 4

**INSTALL HANDLEBAR**

Using the 4mm allen on your 3-way tool, loosen but don't remove the steer tube pinch bolts **(B)** allowing you to loosen the stem and rotate forward **(C)**. Put the handlebars in place. Use the guidelines printed on the handlebars to help position them centrally and evenly. Check that the brake, shifter and dropper post cables have a nice flow and are not kinked or twisted in any way.

Replace the stem faceplate and reinsert the bolts **(D)**, first by hand and then with the 4mm Allen key. Gradually tighten the bolts, making sure that the bars are still positioned correctly and that the space between the faceplate and the main body of the stem is even.

When tightening the bolts follow this pattern to ensure even clamping: top left, top right, bottom left, bottom right. Finish off using the torque wrench to 5Nm **(E)**.

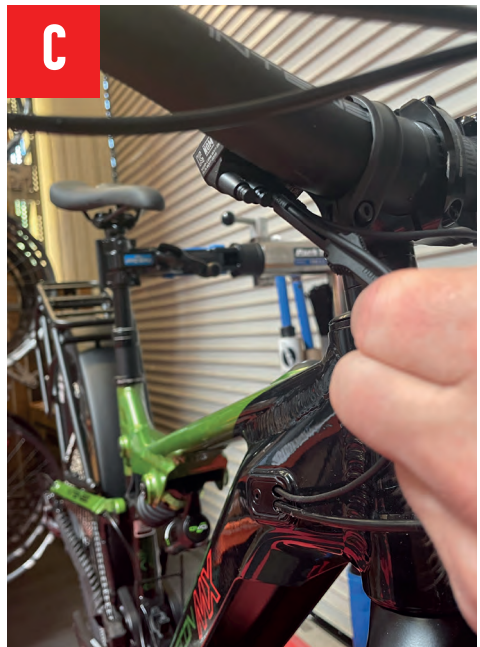



## STEP 5

## CONNECTING THE MOTOR MODE SELECTOR AND DISPLAY WIRES



Included in your accessory box is a special SHIMANO connector tool (the TL-EW300 tool). Use this tool **(A)** to connect the wires to your handlebar display. The tool helps to protect the plug and wire from damage. Slide the plug and wire into the tool as shown, ready for connection.

Sitting on your bike, the cable that comes from the controller (mode selector) on the left-hand side of your handlebars goes into the first hole nearest to the stem (left-hand side), port number 1 **(B)**. Align the plug into the port, then apply a small amount of pressure. There will be an audible click when the cable is fitted correctly. You may need to loosen and rotate the Display Selector slightly to help you gain access to the ports.

The other cable that goes into your frame **(C)** (down to the drive unit/motor) attaches to the second port from the left, port number 2.

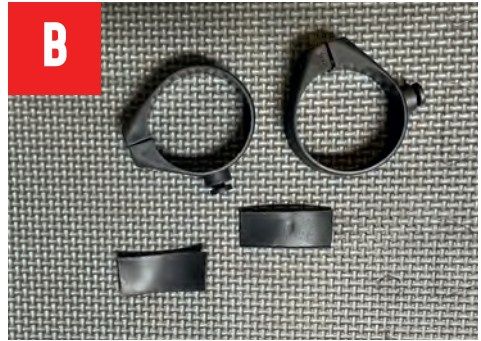

## STEP 6

**INSTALL FRONT  
FENDER**

Start by removing the front fender from the rear wheel packaging by cutting the two zip ties **(A)**. Set front wheel aside and remove remaining packaging on fender. Locate the front fender strut clamps and fork rubber shims located in the black mesh bag that came with your bike **(B)**.

Remove the fender fork bolt with a phillips head screwdriver or bit (may be a 2.5mm hex bolt on some fenders) **(C)**. Next, mount the fender to the fork with a phillips bit and handtighten **(D)**. Next unscrew the bolt on the fender clamp with a phillips head screwdriver or bit and place around the bottom of the fork leg. Take the fender shim pad and place on fork under the clamp to ensure no damage once fender is tightened. Now take the fender strut and place the ending circle on the screw of the clamp and tighten with the phillips bit **(E)**. Repeat this process on the other side and snug both screws.

Now that the fender is on, go back to the top of the fender and push up and tighten the fender in place **(F)** until snug.





## STEP 7

**INSTALL FRONT  
WHEEL**

Remove all packaging from the front wheel making sure the hub end caps are still in the correct place and that they haven't been pulled off by accident **(A)**. If they do come off, just press them back into position. Then remove the brake pad spacer **(B)**. At this stage be careful not to pull the front brake lever until the wheel has been installed. Do not touch the brake rotors with your hands or gloves as this may contaminate them.

With a 6mm Allen key loosen in a counterclockwise direction and remove the front axle from the drive-side of the bike **(C)**.

Position the wheel so that the rotor fits into the brake caliper body and that the hub body slots into the grooves on the fork **(D)**. Once everything is aligned reinstall front axle.

With a 6mm Allen key, and applying some inward pressure, tighten the axle in a clockwise direction **(E)**. Torque to 7Nm.

After front wheel is installed, ensure even spacing of front fender between the fender struts and the tire. If uneven, move the brackets to even out the spacing and re-snug the fender screws with a phillips bit.



## STEP 8

**INSTALL PEDALS**

Bicycles have specific left and right pedals, and the left-hand side pedal has an opposite thread on it, meaning that it tightens up in a counterclockwise direction **(A)**. You need to make sure that you have the correct pedal for each side of your bike. You will see on the pedal axle CR-R (or R) for the right and CR-L (or L) for the left. The right-hand (drive-side) pedal tightens up normally in a clockwise direction.

As mentioned the left-hand (non-drive side) pedal tightens up in a counterclockwise direction **(B)**. Be cautious that the pedals are installed nice and straight, being careful not to cross thread the crankarms. A spot of grease on the thread is good to use here. You can use either a 6mm Allen key or a 15mm spanner/wrench and tighten to 47-54Nm.

## STEP 9

**CHECK GEARS**

Now is a good time to run through the gears to check that they are working correctly. To do this turn the cranks/pedals so that the rear wheel begins to spin. Whilst still pedaling the bike with your hand shift through the gears using the gear shifter on the right-hand side of your handlebars **(C)** (being careful not to trap anything in the chain or wheel). If you are having any issues with the gears, please check out our Tech Video series on the INTENSE website.





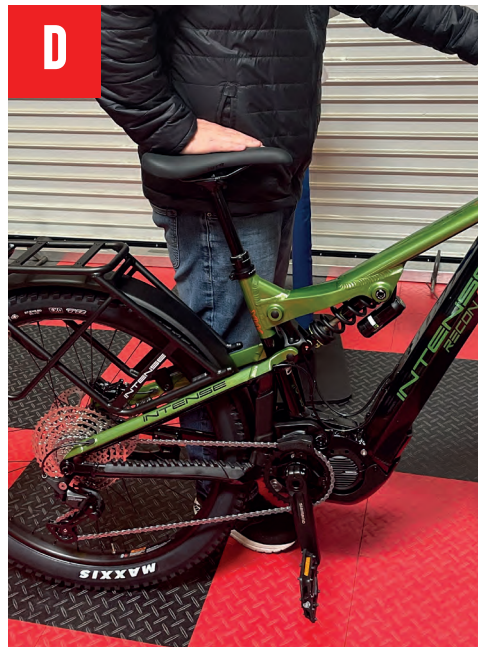

## STEP 10

**ADJUST HEADSET & BARS**

Remove your bike from the bike stand and set on the ground for this step. You want to ensure that your headset moves easily with a very slight amount of resistance, but with no play. You will need to set your headset pre-load to 2-4Nm.

**(A)** If your headset feels a little loose then undo the stem clamping bolts slightly using a 4mm Allen key and then gently tighten the top cap bolt by a quarter clockwise turn or until you reach 2-4Nm **(B)**. Retighten the stem clamp bolts and check the headset again. If the bars don't turn smoothly it is too tight, so repeat the process, but this time slacken the top cap bolt off a little, or if it is too loose, continue to tighten.

Once you are happy with your headset you need to make sure that your stem and handlebars are straight. A good tip is to straddle your bike and look down and line the back of your handlebars up with the front of the fork legs. Take your time, and when you are happy tighten the two stem bolts to 5Nm.

## STEP 11

**ADJUST SADDLE HEIGHT**

Set the height of your saddle (seat) with your dropper seatpost in its fully extended position. **(C)** Using a 4mm Allen key loosen the seatpost clamp and adjust the seatpost to the correct height. A good base measurement is to stand next to your bike in your riding shoes. Putting your hand against the top of your hip bone **(D)**, the palm of your hand should be level with the top of the saddle. Adjust as appropriate, then tighten the seat clamp to 6-8Nm. Do not overtighten this bolt as it may affect the performance of the seatpost. Note: You may need slight saddle height adjustments to ensure optimum comfort.





## STEP 12

## CHECK TIRE PRESSURE

**(A)** The ideal tire pressure setting is determined by three factors: rider weight, type of terrain and the desired balance of comfort and traction. The pressures here are a suggested starting point and can typically range +/- 5psi. Front: 35psi, Rear: 35psi. It is always a good idea to inspect your tires for tears and punctures before and after every ride.

## STEP 13

## INSTALL BOTTLE CAGE

Your bike comes supplied with a water bottle cage. Undo the two 3mm bolts **(B)** on the downtube of your bike and fit the cage **(C)**. Tighten to 3Nm.

## STEP 14

## INSTALL HANDGUARDS

Please refer to instructions from Acerbis on handguard assembly included in the handguard box. Assemble the handguard per instructions then remove the handguard clamp screw **(D)** and place clamp over bars. Push handguard clamp up against the shifter on the right side or the dropper lever on the left side of the bike. Once in place, tighten the handguard clamp bolt with a phillips head screwdriver **(E)**. Repeat the process on the other side.



## STEP 15

**INSTALL  
HANDLEBAR BAG**

Locate the front handlebar bag mount inside the handlebar bag **(A)**. Loosen and remove the two handlebar mount clamp screws using a 4mm allen **(B)**. Then place open handlebar mount clamp around the handlebars ensuring you do not pinch any cables **(C)**. Then place screws back in handlebar mount clamp and tighten with a 4mm allen until snug or clamp has no movement **(D)**. Grab your handlebar bag and line up the bracket on the back of the bag with the mount and slide in until you hear an audible click. Your front bag is now installed **(E)**.



## STEP 16

**INSTALL REAR  
PANNIER BAGS**

Remove packaging from bags. Loosen the bracket at the bottom of the bag by turning the dial **(A)**. Place that bracket over the rack to start **(B)** and once in place, push down on top two bag mount brackets until they click on **(C)**. Once in position, tighten the bottom bag bracket by hand to secure. Repeat process for opposite side bag.

## STEP 17

**INSTALLING TOP  
BUNGEE COVER**

Remove packaging from cover. Open the 4 velcro straps on the bottom of the bungee cover **(D)** and secure to top of rack **(E)**. Complete that process for all straps until bungee cover is secure.



## IMPORTANT INFORMATION

# RECON RACK, FENDER AND BAG SYSTEM

### COMPATIBILITY

This rack, fender and bag system was specifically developed for the INTENSE Recon MX.

### MAXIMUM LOADS

Rack Load should never exceed 27kg (59lb) Mounted Panniers should not exceed 9kg (19lb). Front bag should not exceed 6kg (13lb).

### WARRANTY

One year from date of sale coverage on materials and workmanship. Proof of purchase required. INTENSE will repair or replace at our discretion.

### GENERAL WARNINGS

This system is NOT INTENDED for passengers. DO NOT attempt to carry any passengers.

Do not use with a trailer or child seat.

Do not use in aggressive mountain bike riding. Wheels should not leave the ground while bags are attached.

Only attach panniers to properly installed bike rack. Always distribute load evenly between both sides and sinch down.

Do not exceed maximum loads. Always ensure load is distributed evenly. A loaded rack or bags will influence handling and braking ability.

Only use bags that are compatible with your bicycle. See Compatibility section.

Do not use a worn-out bag. Overtime exposure to the elements will result in damage to the bag. When not riding do not store bags in direct sunlight. Replace your bags when they are worn or damaged.

For safety reasons always remove all bags and accessories from your bicycle before transporting on a motor vehicle.

Do not attempt to modify bicycle, bags or attachment system. Modifications may introduce a risk to your own safety or the safety of others.

INTENSE DOES NOT authorize any modifications, and therefore, cannot accept liability for any damages or injury that may be a result of unauthorized modifications.

**BEFORE RIDING**

Make sure your bicycle is in good working order and ensure your racks and fenders are installed properly and functioning correctly.

Remember that a loaded rack or bag may alter the handling and performance of your bicycle.

Always secure loads and never exceed the max recommended weight of the bicycle or rack and bag system

Check that all accessories and bags are attached according to manufactures instructions and do not have any loose or dangling straps that could get caught in spokes or chain. Maintain 2inches or 50mm of clearance.

Make sure your reflectors and lights are still visible with bags and rack installed. Check your bags periodically during your ride to ensure they are in place and retighten if needed.

**REAR RACK GENERAL WARNINGS**

This rack is NOT INTENDED for passengers. DO NOT attempt to carry any passengers.

Do not exceed maximum loads. Always ensure load is distributed evenly. A loaded rack or bags will influence handling and braking ability.

Do not attempt to modify this rack and fender as they are specifically designed and tuned to work with your bicycle and suspension system. Modifications may introduce a risk to your own safety or the safety of others. INTENSE DOES NOT authorize any modifications, and therefore, cannot accept liability for any damages or injury that may be a result of unauthorized modifications.

Always inspect your bicycle and accessories before riding.



## STEP 18

**INSTALL  
BATTERY**

Once your battery is fully charged (see page 48) you need to reinstall it back into the bike.

Install the battery by inserting the lower tab of the battery into the tab recess hole on the frame of the bike at an angle of approximately 45° **(A)**.

Making sure that everything is aligned correctly, simply hinge the battery upwards into position using gentle pressure to push it into place **(B)**.

With the battery almost in its final position, use gentle pressure to push it into place, you will hear an audible click as it locates and locks itself into place **(C)**.

The battery is now locked in position. If you want to remove the battery you will need to use the key provided with the battery. See page 13 for more information.

Do not force the battery into the opening, as it can result in damage to the battery or terminal.



*FORK: DVO DIAMOND E3*

## *SUGGESTED STARTING POINTS FOR SETTING FORK SAG*

RIDER WEIGHT		AIR
(lbs)	(kgs)	PRESSURE (psi)
120-130	54-59	80-85
130-140	59-64	80-85
140-150	64-68	85-90
150-160	68-73	85-90
160-170	73-77	90-95
170-180	77-82	90-95
180-190	82-86	95-100
190-200	86-91	95-100
200-210	91-95	100-105
210-220	95-100	100-105
220-230	100-104	105-110
230-240	104-109	105-110
240-250	109-113	110-120



## STEP 19

## FRONT SUSPENSION SET-UP

Out of the box your fork settings are generally set up for a rider weighing between 130-140lb (59-63.5kg). To adjust the suspension to your weight simply add some air or take some out. Your weight should be calculated when you are in full riding gear (including helmet, and if you regularly use one, your backpack).

It is important to get good base settings for your suspension that you are happy with. It is easy to get confused with all the different variables of settings, so remember to write everything down as you go along. You can take note of air pressure, rebound clicks and any other suspension details.

**ADJUSTING AIR PRESSURE (DVO):** The DVO fork on the Recon MX has just one main air chamber on the left leg. The Schrader valve (car tire type) can be found on the upper left fork leg under a green protective cap (A).

Please refer to the air pressure chart opposite for recommended settings.

## STEP 20

# SETTING FORK SAG

You now need to measure the 'sag' of the fork. Sag is important as it allows the fork to work properly. With the help of a friend sit on the bike in a normal riding position in full riding gear, pedals level. Bounce up and down on the bike a few times and then gently sit back down. Do not touch the brakes.

The rubber O-ring is on the left leg and is green **(A)**. Get your friend to slide this down until it touches the top of the fork. Carefully get off the bike without further compressing the forks (your friend can help here by holding the handlebars so they don't drop).

When the bike is unweighted, the fork will be fully extended and leave a gap between the fork seal and the O-ring. The distance between these two is your sag measurement. You are looking for approximately 20% sag – which is 32mm. Use a ruler to measure the gap.

Adjust the air pressure in your forks until you reach the correct sag measurement **(B)**. If you don't have enough air just pump more in using the shock pump that came with the tool kit. If you have too much air just briefly press the small button on the shock pump, this will release small amounts of air from the system. Once finished, replace the protective caps.

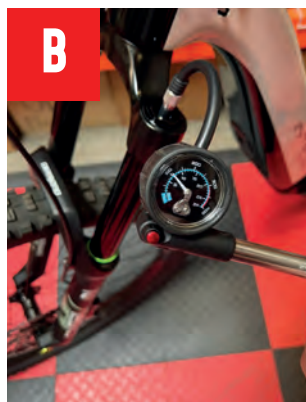



## STEP 21

**SETTING FORK REBOUND**

The rebound setting on your fork is how quickly your suspension reacts to impacts and returns to its normal position after compression. Your rebound settings can vary depending on the terrain you are riding on, your riding style, etc. A fast rebound setting is good when you need the fork to react quickly over continuous rough ground, but not so good, if for example, you are going off a lot of big drops where the faster rebound may pitch you forward too quickly. As with most things, finding a middle ground is best – not too fast, and not too slow – and then tweaking and refining as you begin to understand how your bike and suspension feels and reacts.

The rebound adjuster for the fork is a silver dial located on the bottom of the right leg **(A)**.

The rebound adjustment is dependent on your air pressure setting. For example, higher air pressure requires more rebound damping. Use your air pressure to find your rebound setting. Turn your rebound knob to the closed position (fully clockwise) until it stops. Then back it out (counterclockwise) to the number of clicks shown in the tables overleaf.

**REBOUND****Open**

*(counterclockwise)*

*Least amount of rebound damping. Fork rebounds fastest.*

**Closed**

*(clockwise)*

*Most amount of rebound damping. Fork rebounds slowest.*



STEP 21 CONTINUED...

## FRONT SUSPENSION SET-UP

FORK: DVO DIAMOND E3

### SUGGESTED REBOUND SETTINGS

RIDER WEIGHT (lbs)	(kgs)	DVO # of clicks
120-130	54-59	10-14
130-140	59-64	10-14
140-150	64-68	8-12
150-160	68-73	8-12
160-170	73-77	6-10
170-180	77-82	6-10
180-190	82-86	6-10
190-200	86-91	6-10
200-210	91-95	6-10
210-220	95-100	6-10
220-230	100-104	4-8
230-240	104-109	4-8
240-250	109-113	4-8

(Number of clicks from fully closed. Each click above represents a counterclockwise turning motion.)



## HIGH AND LOW SPEED COMPRESSION ADJUSTERS

We recommend that you refer to the manufacturer's website or instruction manual for full technical details and further information on the specific fork (or rear shock) that you have on your bike.

[www.dvosuspension.com](http://www.dvosuspension.com)

Two of the most common adjustments are High and Low Speed Compression. High and Low do not refer to the speed that you are traveling at, but rather the speed that the fork or shock moves as it reacts to trail obstacles and rider inputs.

Pedaling or weighting the bike through turns are two good examples of where Low Speed Compression adjustment (LSC) can affect the suspension feel. Braking bumps or big drops (where the suspension moves quickly through its travel) are good examples of where High Speed Compression (HSC) adjustment can help. The more compression damping you have the firmer the suspension will feel, offering more support.

## STEP 22

# REAR SUSPENSION SET-UP

First check the spring rate-chart on this page to make sure that the spring fitted on your Recon MX is within range for your rider weight. If the spring is too hard or too soft you will need to change it. Please see our Tech Videos section on our website to see how to change the coil on your shock.

### SPRING RATES AS STANDARD

DVO JADE R COIL

Size SM/MD: 450 lb

Size LG/XL: 550 lb

Rear wheel travel: 140mm (5.51"). Shock stroke: 55mm (2.15"). Shock sag: 30% when sitting on the bike. Shock preload: Min-1.5 turns / Max-5 turns.

*SHOCK: DVO JADE R COIL*

### SUGGESTED STARTING POINTS FOR SETTING UP YOUR SHOCK

RIDER WEIGHT		SPRING RATE	REBOUND CLICKS	LOW SPEED	HIGH SPEED
(lbs)	(kgs)	DVO			
100	45	343	11	14	12
110	50	350	10	14	12
120	54	350	9	14	12
130	59	400	9	14	12
140	63.5	400	8	14	12
150	68	450	8	12	10
160	73	450	7	12	10
170	77	500	7	12	10
180	82	500	6	12	10
190	86	550	6	12	10
200	91	550	5	10	8
210	95	600	5	10	8
220	100	600	4	10	8
230	104	650	3	10	8
240	109	650	2	10	8
250	113	700	1	10	8

(Rebound: Clicks out from fully closed. Low speed and high speed refers to compression.)



## STEP 23

**SETTING SHOCK SAG**

Just as you did with your forks you now need to set the sag on your rear shock. The optimal sag on your rear shock is 30% of the piston's movement inside the shock body (stroke). The distance between the two shock mounting bolts (eye-to-eye) without a rider on the bike is 185mm for both shocks. Sag at 30% (of the piston) equates to a 16mm reduction in the eye-to-eye measurement. So the correct eye-to-eye measurement for 30% sag on this shock is 169mm (185-16 = 169mm).

With the help of a friend, sit in a normal riding position in full riding gear on the bike, pedals level. Bounce up and down on the bike a few times and then gently sit back down. While still sitting on the bike, and with the shock slightly compressed (sag), measure the length of the shock (eye-to-eye) and record that number **(A)**. To check the amount of sag just minus the original number from the new measurement, that will be your sag measurement. If the eye-to-eye measurement is 169mm that will give you a sag measurement of 16mm, which gives you the exact 30% sag rate you are looking for.

While adjusting your rear shock sag, keep in mind that you must keep your total turns of spring preload at a minimum of two turns and a maximum of five turns. If your sag number is higher than 30%, increase the spring preload by turning the preload collar clockwise (2-5 turns) **(B)**. If your sag number is lower than 30%, decrease the spring preload by turning the preload collar counterclockwise (minimum of two turns from base). Check the sag measurement again and adjust as necessary. If you cannot get the correct sag you will probably need a different spring rate for your bike.



## STEP 24

# SETTING SHOCK REBOUND

Just like for your fork, the rebound setting on your rear shock is how quickly it reacts to impacts and returns to its normal position after compression. Your rebound settings can vary depending on the terrain you are riding on, your riding style, etc. As with most things, finding a middle ground is best – not too fast, and not too slow – and then tweaking and refining as you begin to understand your bike and suspension feel. It is a green dial (A), both are located on the bottom of the shock by the end of the coil.





GETTING TO KNOW YOUR RECON MX

## **INTENSE BICYCLE IDENTIFICATION**

It's important to keep track of your Recon MX's serial number as well as the serial numbers of its important components for warranty and replacement purposes. Included in your Accessory Kit is a serial number sheet. Please keep this in a safe place.

**Please also note down and register the unique identifiers of your battery's key below.**

You will need to know the key type, code and profile. It means that if you ever lose your key you can simply and quickly order a replacement.

KEY TYPE:

WAFER

KEY CODE:

KEY PROFILE:

To register your key or to order a new one, please visit [www.mobilesecurity.abus.com](http://www.mobilesecurity.abus.com).

**WARNING!** USE THE SUPPLIED KEY TO REMOVE THE BATTERY FROM THE FRAME, TO PERFORM A BATTERY SWAP OR FOR CHARGING. DO NOT MOVE OR ALTER THE BATTERY FRAME MOUNTS FROM THEIR FACTORY POSITION IN THE DOWNTUBE AS THIS COULD RESULT IN SUBPAR PERFORMANCE, MAY LEAD TO BATTERY AND OR FRAME DAMAGE AND IS NOT COVERED UNDER WARRANTY. PLEASE CONTACT THE INTENSE TECH CENTER IF YOU HAVE ANY QUESTIONS RELATING TO THE BATTERY MOUNTS.

**INTENSE**  
9TE7PROM-YEL  
9TE7PROM-YEL  
TAZER E-BIKE - YEL

PO: 25543  
CODE : UN 3481  
QTY: 1 SET C/NO.: 4  
COUNTRY: MADE IN TAIWAN

UPC NO.: 8 1151103761 0  
FT NO.: VN18E00674  
RT NO.: VN18E00368  
LINK NO.: NA  
FORK NO.: 184201-0014-T  
MOTOR: 72FQFS2212C  
SWITCH: 0BKQEY107EE  
KEY NO.: T82 7747  
DISPLAY: 72KQEC24322  
BATTERY: NA  
PART: 119INTE1IN010102  
SO-18075013 321485



← EXAMPLE SERIAL NUMBER SHEET. PLEASE REFER TO YOUR ACCESSORY KIT FOR YOUR OWN SERIAL NUMBER SHEET



## HOW TO USE YOUR RECON MX

# GET CHARGED

The battery in your Recon MX is not fully charged at the time of purchase, so before you can use your new bike you will need to charge it using the supplied SHIMANO battery and its dedicated charger. The SHIMANO 504 Wh battery found in the Recon MX will take up to 10 hours to fully charge.

You can charge the battery in the frame or you can take it out to charge elsewhere. See pages 12-13 for how to remove the battery from the frame.

To charge the battery when it is in the bike firstly locate the charging port in your bikes frame. For the Recon MX this is located above the motor where the downtube meets the seattube above the lower link. Simply pull back the rubberized cover to access the charging port, then insert the charging plug into the charging port. The charging plug will only fit into the charging port one way. Plug the charging cable into your wall outlet.

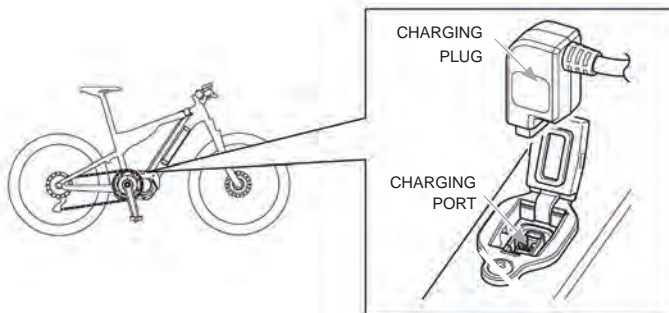

Both the SHIMANO Battery and SHIMANO Charger indicator lights will light up. The yellow charger light shows that it is charging correctly. The green lights on the battery itself will blink while charging and become completely solid when fully charged.

When the battery is completely charged, both it and the

charger will turn off, but it is good practice to unplug and turn the charger off once the battery is fully charged. You can also remove the battery from the bike (see page 13) and charge using the ports illustrated below.

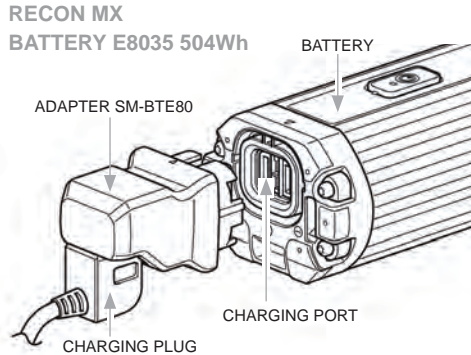

**IMPORTANT POINTS REGARDING YOUR BATTERY**

We do not recommend that you charge your battery overnight.

Charging can be carried out at any time regardless of the amount of charge remaining, but we recommend you charge the battery until it is fully charged.

Only use the dedicated SHIMANO charger that came with your bike when recharging the battery.

If the battery has become fully spent, charge it as soon as possible. If you leave the battery without charge it will deteriorate.



If your Recon MX will not be ridden over an extended period of time, store it away with approximately 70% battery capacity remaining. Also take care not to let the battery become completely empty by charging it every six months.

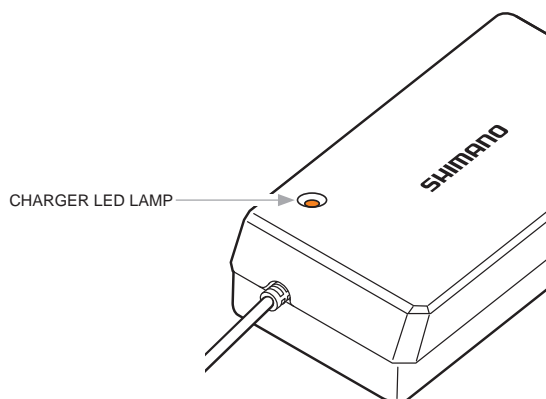

## CHARGER INFORMATION



**AS CHARGING STARTS THE LED LAMP ON THE CHARGER LIGHTS UP.**

-  **LIT UP** Charging (and within 1 hour after completion of charging)
-  **BLINKING** Charging Error
-  **TURNED OFF** Battery disconnected (1 hour or more after completion of charging)

## TURNING ON YOUR RECON MX eBIKE

The power ON/OFF button is located on the toptube, toward the front of your bike. It is easy to find and simple to use. Press and hold the power button until you hear an audible 'beep'. The green LED lights on the Power ON/OFF button will come on at this stage, and the computer display on your handlebars will be activated.

Please note that the battery cannot be turned on whilst it is charging, if the bike is moving or if you have your feet on the pedals. A 'system error' may occur (see page 60).

To turn off. With your feet off the pedals, simply hold down the power button for a few seconds until the system shuts down. The handlebar display will go blank.



### **AUTOMATIC 'POWER OFF' FUNCTION**

If the bicycle has not moved for over 10 minutes, the power will automatically turn off.

## USING THE POWER MODES

Your Recon MX motor comes with three main assist modes: BOOST, TRAIL and ECO, and a fourth WALK mode. You can easily toggle between the three modes using the Assist Switch that's located on the left-hand side of your handlebars. Assistance only starts when you begin to pedal. You can switch between modes at any time depending on the amount of assistance you require.

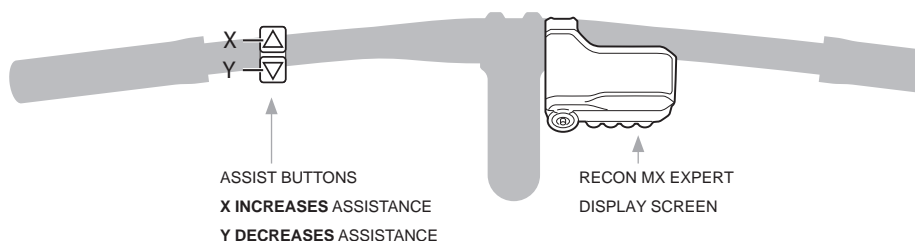

### IMPORTANT: THE LAW AND eBIKES

Your Recon eBike speed is restricted by law. The limit in the USA is 20mph (32km/h) and in Europe it is 15.5mph (25km/h). When these speeds are reached the motor power will cut out. Power to the motor will only return when the speed drops below those limits.

**BOOST**

BOOST Mode is a lot of fun, especially on long steep climbs and if you're looking to minimize rider effort for a fantastic riding experience. BOOST will consume the battery the fastest.

**TRAIL**

TRAIL mode is the primary mode you will find yourself using for most single track riding. It offers all the power of BOOST mode, however it does require more input from the rider. This truly is the most realistic assisted riding experience available. TRAIL is a great balance of efficiency and power based on the needs of the rider. This makes TRAIL mode require less battery than BOOST and will give the rider more range.

**ECO**

ECO mode is all about efficiency and providing the most range out of the available modes. With this it does provide the least amount of assistance, which will require more input from the rider to maintain speed. This mode is great for long days on the bike where battery conservation needs to be considered or as a training and fitness tool.

**WALK**

WALK mode is very useful if you are out exploring and find yourself in a situation where you need to walk your bike up a hill. This mode will help to take care of the weight of the bike and make the push up the hill much easier.

All of the riding modes are extremely tunable through the SHIMANO Steps App. The app allows the rider the ability to set up two separate tune profiles and have the ability to adjust between the two on the fly.

When considering the expected range for each one of these modes it is important to note that there are many factors that introduce variables. Factors such as rider weight, riding style, gear selection, soil type, hilly terrain and tire pressure, etc.

## CHANGING THROUGH THE MODES

You only get assistance from the motor when you start to pedal. The motor 'kicks in' almost immediately with a nice, smooth transition. On the Assist Switch controller use the up and down arrows to move between the different modes.

When you first turn the battery on, the display will light up and show 'OFF' in the bottom left corner. Use the up arrow (X) to move into ECO mode, press it again for TRAIL, and again for BOOST. Pressing the down arrow (Y) will take you back down through those modes.

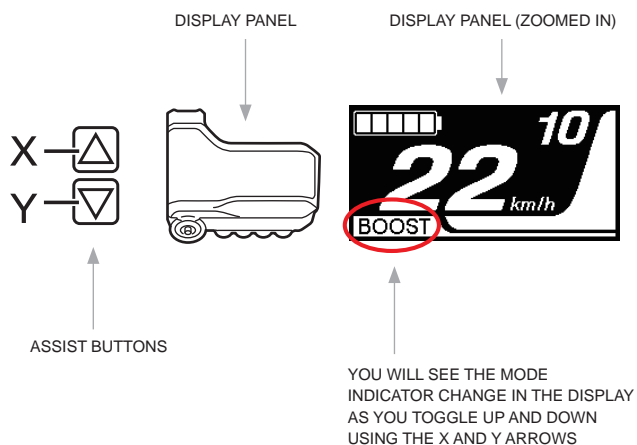



In a safe area, away from traffic, go through the different modes as you pedal around, feeling the different levels of assistance. As you change between the modes you can keep pedaling, and don't forget to try the different modes in different gears to get the best feel for your bike.

To use the WALK function you need to be off the bike, with your feet off the pedals and the bike stationary. Press and hold the down arrow (Y) until WALK appears in the display. Release the down button, then press and hold it down to activate the motor into WALK mode. The level of assistance is only small (a max of 3.7mph), and it will depend on what gear you are in, but it can be a useful helping hand in certain situations.

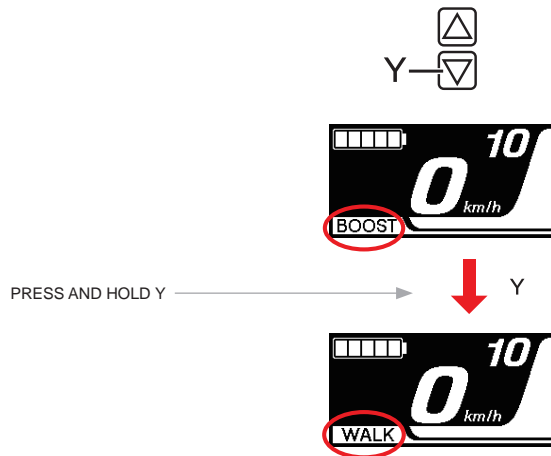

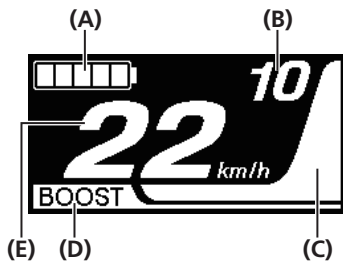

## SCREEN DISPLAY

The Screen Display is your 'eyes on the system'. It shows information such as what mode you are in, the speed you are going and more.

### A. Battery level indicator

Displays the current battery level.

### B. Gear position

Displays the current set gear position. Only displays when electronic gear shifting is in use. The Recon MX comes with mechanical shifting as standard.

### C. Assist gauge

Assistance output indicator.

### D. Assist mode display







Displays the current assist mode.

### E. Current speed

This can be switched between mph and km/h.

# BATTERY LEVEL INDICATOR

The battery level indicator is located in the top left of the display screen. You can monitor the battery level as you ride.

BATTERY LEVEL INDICATOR ON DISPLAY UNIT	
BATTERY LEVEL INDICATION*1	BATTERY LEVEL
	81% – 100%
	61% – 80%
	41% – 60%
	21% – 40%
	1% – 20%*
	0%

\*The battery level indicator blinks red when remaining battery level falls to this level.

## SHIMANO'S E-TUBE APP

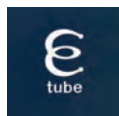

Your Recon MX comes with pre-set 'profiles', which we believe to be the perfect level of power and assistance in each of the modes for this model of bike.

The Recon MX (SHIMANO E-7000 motor) comes with one pre-set profile.

For those of you who would like to fully customize your bike's settings to match your riding style SHIMANO's E-Tube App allows you to truly personalize your riding experience. Simply download the App to your smartphone, enter your details and connect to your bike via Bluetooth.

You will then be able to work your way through the menu where you can do things like tweak the motor unit's performance and assist modes, store different rider profile settings, identify error codes and get solutions, update firmware, check for latest releases and the newest functions, etc.

The most important adjustments for the motor output are the assist characteristic (the amount the motor multiplies the rider input), the maximum torque (the 'pulling force') and assist characteristic at the start (how quickly the bike reacts to rider input). It can be tricky to balance all these elements, and it is best to adjust one setting at a time and evaluate how it feels.

With the power system on (and no weight on the bike), press and hold the selection button on the bottom of the display screen to open the 'Setting' menu. Using the Assist Switch controller (mode selector) on the left of your handlebar, scroll down to the 'Assist

# HOW TO ACCESS THE PRE-SET CUSTOM PROFILE

Customize' option. Using the selection button on the bottom of the display, select 'Assist Customize'. Using the mode selectors on the left of the handlebar, select your desired 'Profile'.

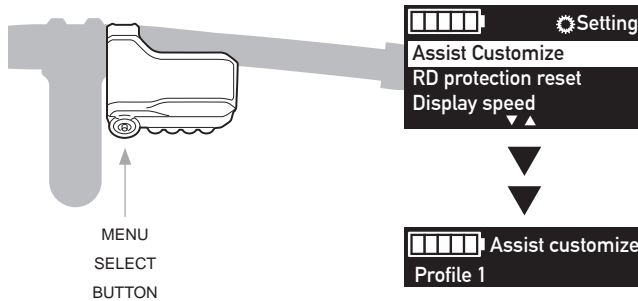

**E-Tube App Link**  
[www.e-tube.shimano.com](http://www.e-tube.shimano.com)  
 (scan QR code for direct access)





**Additional Links:**  
[www.e-tubeproject.shimano.com](http://www.e-tubeproject.shimano.com)  
[www.e-tubeproject.shimano.com/application](http://www.e-tubeproject.shimano.com/application)





# TROUBLESHOOTING

## BATTERY LED ERROR INDICATORS

System errors and similar warnings are indicated by the battery LED through various lighting patterns.

BATTERY ERROR INDICATOR	
LIGHTING PATTERN	ERROR INDICATION TYPE
	SYSTEM ERROR
	TEMPERATURE PROTECTION
	SECURITY AUTHENTICATION ERROR
	CHARGING ERROR
	BATTERY MALFUNCTION

 NO LIGHT    LIT UP    BLINKING

INDICATION CONDITION	RECOVERY
<p>Communication error with the bicycle system.</p>	<p>Make sure that the cable is not loose or improperly connected. If the situation does not improve, contact the place of purchase.</p>
<p>If the temperature exceeds the guaranteed operating range, the battery output is turned off.</p>	<p>Leave the battery in a cool place away from direct sunlight until the internal temperature of the battery decreases sufficiently. If the situation does not improve, contact the place of purchase.</p>
<p>This is displayed if a genuine drive unit is not connected. This is displayed if any of the cables are disconnected.</p>	<p>Connect a genuine battery and drive unit. Check the condition of the cables. If the situation does not improve, contact the place of purchase.</p>
<p>This is displayed if an error occurs during charging.</p>	<p>Remove the charger from the battery and press the power button. If an error appears contact the place of purchase.</p>
<p>Electrical failure inside the battery.</p>	<p>Connect the charger to the battery and then remove the charger. Press the power button with only the battery connected. If an error appears with only the battery connected, contact the place of purchase.</p>

## WARNING AND ERROR MESSAGES ON THE CYCLE COMPUTER DISPLAY

Warning and Error messages are displayed at the top in the middle of the computer display screen. These messages usually start with a 'W' and help you identify the problem. Some of the most common error messages can be found printed on the inside of the battery hatch door.

### WARNING MESSAGES ON DISPLAY

CODE	DISPLAY PRECONDITIONS
W010	Temperature of the drive unit is higher than it is during times of normal operation.
W011	The travelling speed cannot be detected.
W013	Initialization of torque sensor was not completed successfully.
W032	An electronic derailleur may have been installed in place of a mechanical derailleur.

WARNING MESSAGE ON THE DISPLAY SCREEN. THIS DISAPPEARS ONCE THE ERROR IS FIXED.



OPERATIONAL RESTRICTION	REMEDY
Power assistance may be lower than usual.	Stop using the assist function until the temperature of the drive unit drops. If the situation does not improve contact the place of purchase.
The maximum speed up to which power assistance is provided may be lower than usual.	Check that the speed sensor is properly installed. If the situation does not improve contact the place of purchase.
Power assistance may be lower than usual.	With your foot off the pedal, press the battery power button and turn on the power again. If the situation does not improve contact the place of purchase.
Power assistance provided in (WALK) mode may be lower than usual. The walk assist function may not be able to be used in certain regions.	Reinstall the derailleur for which the system is configured to support. If the situation does not improve contact the place of purchase.



For a complete list of **SHIMANO Error Codes** and how to fix them scan the code.

---

## **MAINTENANCE**

You have purchased a high-performance bicycle which requires a certain level of service and maintenance to sustain the level of performance your frame was designed around. Proper care will also ensure the bike is safe to ride at all levels. It is important to read and understand the care information as well as follow the maintenance schedule and inspect your bicycle before each ride. This will help to limit or avoid costly repairs and will also help to avoid injury due to service neglect and component failure.

## **CARE**

- Use a soft cloth with warm soapy water to clean the aluminium surfaces. Do not use high pressure washers, abrasive cloths or cleaner.
- Be sure all frame surfaces in contact with cables are protected. Cable housing rubbing on the frame can wear over time.
- Be sure brake levers, handlebar ends and the fork crown do not contact the frame at full rotation.
- Never clamp any part of the frame in a bike stand or car rack.
- Always inspect your frame if you experience any chain suck.
- Always inspect your frame in full after a crash to be sure there is no damage. Look for cracks or dents. If you discover damage to any degree it's best to have your frame inspected by a qualified INTENSE Recon MX dealer. Any direct impact to the frame can cause serious structural damage.
- Use high-grade waterproof grease on seatpost, BB and headset bearing contact areas.
- Be sure to follow all recommended torque settings.
- Use only genuine replacement parts for safety-critical components.



**RECON MX  
MAINTENANCE SCHEDULE**

	ACTION	EVERY RIDE	500 MILES OR 1MTH	2000 MILES OR 6 MTHS	4000 MILES OR 1 YR
<b>TIRES</b>	CHECK AIR PRESSURE, INSPECT TREAD AND SIDEWALLS FOR TEARS AND PUNCTURES	X			
<b>CHAIN</b>	BRUSH OFF AND LUBRICATE	X			
<b>BRAKES</b>	SQUEEZE BRAKES AND CONFIRM FUNCTION	X			
<b>GENERAL</b>	CLEAN COMPLETE BIKE OF MUD AND DEBRIS	X			
<b>HEADSET</b>	CHECK ADJUSTMENT		X		
<b>BOX LINK</b>	ADD GREASE THRU ZERK FITTINGS		X		
<b>FRAME PIVOTS</b>	CHECK TORQUES		X		
<b>SPOKES</b>	INSPECT FOR DAMAGE, CHECK TENSION		X		
<b>SHOCK &amp; FORK</b>	CHECK AIR PRESSURE, INSPECT FOR LEAKS		X		
<b>CHAIN</b>	INSPECT FOR DAMAGE AND CHECK FOR STRETCHING		X		
<b>BRAKES</b>	REPLACE BRAKE PADS			X	
<b>DERAILLEUR</b>	INSPECT CABLES AND LUBE			X	
<b>SEATPOST</b>	CLEAN AND REGREASE INTERFACE WITH FRAME			X	
<b>FRAME PIVOTS</b>	REMOVE PIVOT BOLTS, CHECK BEARINGS FOR PITTING AND WEAR			X	
<b>HEADSET</b>	DISASSEMBLE STEM, HEADSET AND FORK. CHECK BEARINGS FOR PITTING AND WEAR			X	
<b>HUBS</b>	PULL WHEELS OFF, CHECK HUB BEARINGS FOR PITTING AND WEAR			X	
<b>BOTTOM BRACKET (BB)</b>	REMOVE CRANKARMS AND CHECK BB BEARINGS FOR PITTING AND WEAR			X	
<b>GENERAL</b>	COMPLETE TUNE-UP				X



### RECON MX SPEC

DISPLAY	SHIMANO SC-E7000
SWITCH	SHIMANO SW-E7000-L
FORK	DVO DIAMOND E3 27.5", 160MM, 44MM RAKE
SHOCK	DVO JADE R COIL, 140MM TRAVEL, 185 X 55MM, SPRING 450LB S/M AND 550LB LG/XL
WHEELSET	WTB ST I35 TCS 27.5", 35MM FRONT/REAR, INTENSE E-MTN ALLOY HUBS
REAR DER.	SHIMANO RD-M5100 DEORE 11-SPEED
SHIFTER	SHIMANO SL-M5100 DEORE 11-SPEED
CRANK	SHIMANO FC-E8000 165MM, 34T
CASSETTE	SHIMANO CS-M5100 11-SPEED, 11-51T
CHAIN	KMC E 11-SPEED
BRAKES	TRP HD-M843 TRAIL EVO
ROTOR	TRP 203MM FRONT/REAR
POST	INTENSE RECON DROPPER 31.6MM, 125MM SM/MD, 150MM LG/XL
TIRES	MAXXIS REKON 27.5 X 2.80" 3C, EXO+, TR
HEADSET	INTENSE ZS49/ZS56
BAR	INTENSE RECON 35 ALLOY 800MM, 30MM RISE
STEM	INTENSE RECON 35 ALLOY 45MM
GRIPS	INTENSE LOCK-ON
SEAT	WTB VOLT
COLOR	GREEN
SIZES	SM/MD, LG/XL

RECON MX

**GEOMETRY  
CHART**

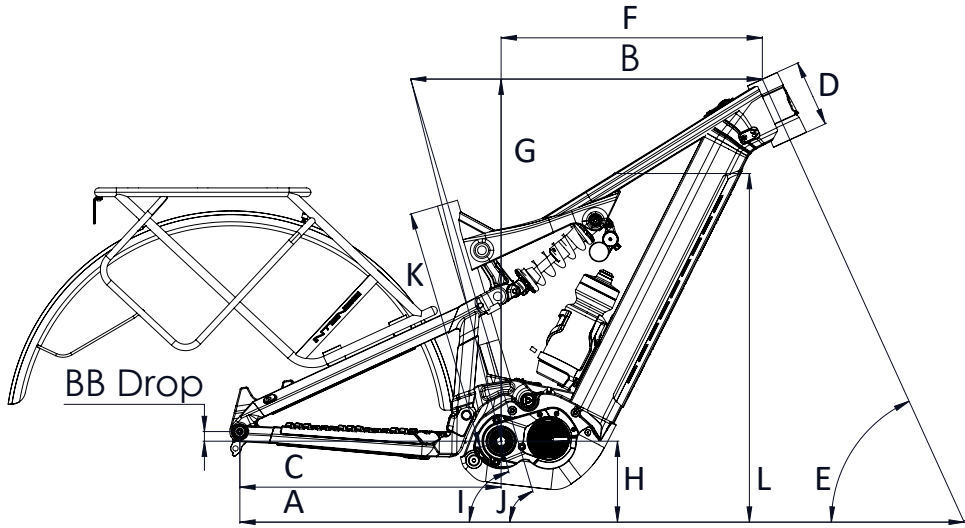

**RECON MX**

SIZE	SMALL/MEDIUM	LARGE/X-LARGE
WHEELBASE: A	1227 MM / 48.3"	1286 MM / 51"
TOPTUBE LENGTH: B	606 MM / 23.9"	664 MM / 26.2"
CHAINSTAY LENGTH: C	450 MM / 17.7"	450 MM / 17.7"
HEADTUBE LENGTH: D	115 MM / 4.5"	125 MM / 4.9"
HEADTUBE ANGLE: E	65.25°	65.25°
REACH: F	447 MM / 17.6"	502 MM / 19.8"
STACK: G	625 MM / 24.6"	634 MM / 25"
BB HEIGHT: H	344 MM / 13.55"	344 MM / 13.55"
BB DROP	16.5 MM / 0.65"	16.5 MM / 0.65"
SEATTUBE ANGLE (EFFECTIVE): I	75.7°	75.7°
SEATTUBE ANGLE (ACTUAL): J	73.25°	73.25°
SEATTUBE LENGTH: K	419 MM / 16.5"	470 MM / 18.5"
STANDOVER HEIGHT: L	805.8 MM / 31.7"	817 MM / 32.2"

# EXPLODED VIEW AND PARTS RECON MX

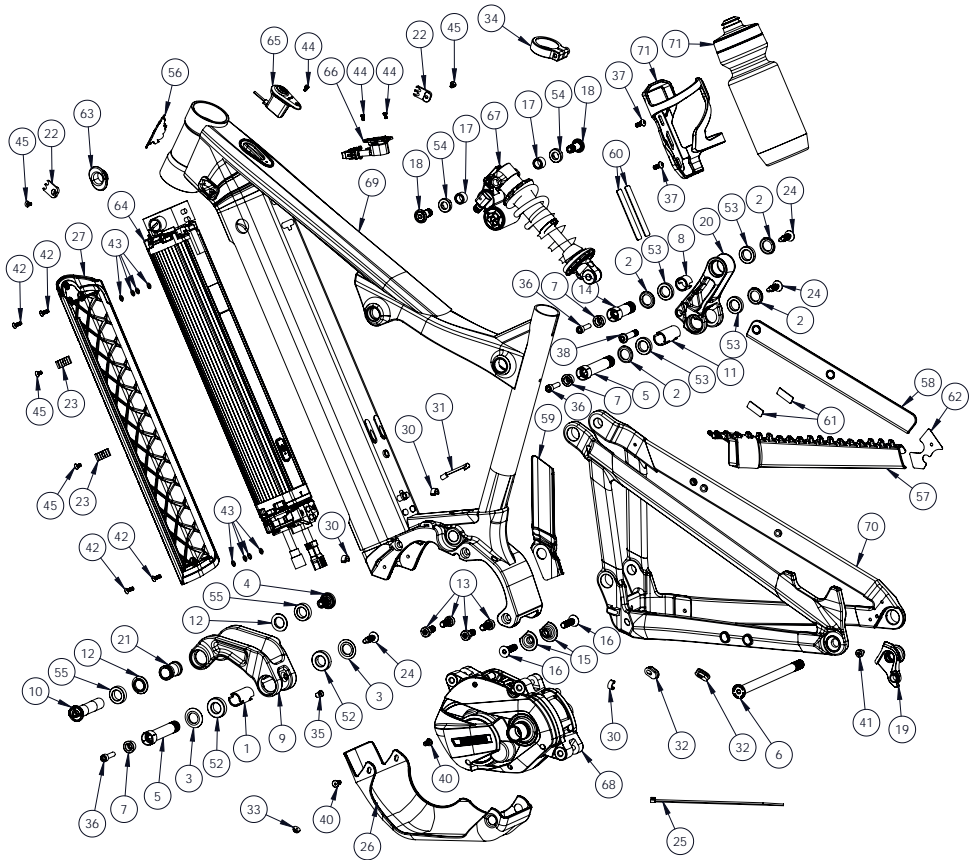

ITEM NO.	ITEM	PART NUMBER	DESCRIPTION	QTY.	TORQUE SPEC.
----------	------	-------------	-------------	------	--------------

1	Crush Tube	130754	Lower Link Crush Tube	1	N/A
2	Bearing Cap 24mm OD	130765	Cap Bearing Blk	4	N/A
3	Bearing Cap	130778	Cap Bearing Blk	2	N/A
4	Bolt Shoulder	130785	Bolt Shoulder Fine Thread	1	20 Nm / 175 in-lbs
5	Bolt Main Pivot	130795	Bolt Main Pivot 1.5T Blk	2	7 Nm / 60 in-lbs
6	Rear Axle	130799	Axle Rear 148 x 12mm Boost Blk	1	11 Nm / 100 in-lbs
7	Cone Adjuster	130807	Spacer Cone Adjuster Blk, 8.3mm Height	3	N/A

8	Crush Tube Recon	130847	Crush Tube Top Link Recon	1	N/A
9	Forged Lower Link	130848	Forged Lower Link Recon, Blk	1	N/A
10	Axle Lower	130850	Axle Lower Pivot Recon	1	20 Nm / 175 in-lbs
11	Crush Tube Recon	130851	Crush Tube Top Link Recon	1	N/A
12	Pivot Axle Spacer	130860	Pivot Axle Spacer	2	N/A
13	Drive Unit Bolt	130862	Drive Unit Bolt M8 x 18 with T40 Broach	4	10 Nm / 88 in-lbs
14	Collet Bolt Top Link	130863	Collet Bolt Top Link/ Front Triangle	1	7 Nm / 60 in-lbs
15	Skidplate Spacer	130867	Skidplate Spacer, Recon	2	N/A
16	Skidplate Motor Bolt	130868	M8 x 1.25 x 30 mm, Skidplate Motor Bolt	2	10 Nm / 88 in-lbs
17	Spacer Trunnion Mount	130869	Spacer 10 mm Length, Trunnion Mount	2	N/A
18	Trunnion Bolt	130870	Bolt Shoulder 22.6 mm length, Trunnion Shock, Recon	2	16 Nm / 140 in-lbs
19	Derailleur Hanger	130897	UDH Universal Derailleur Hanger, GW, P/N 411H0300001	1	25 Nm / 221 in-lb
20	Forged Top Link Recon	130904	Forged Top Link Recon, Blk	1	N/A
21	Pivot Tube	130911	Motor Mount Pivot Tube, Recon Alloy	1	N/A
22	Guide Plate	130912	Cable Routing Guide Plate, Recon Alloy, 12-174-000	2	N/A
23	Cable Guide Clamp	130913	Cable Guide Clamp, Recon Alloy, DT Cables	2	N/A
24	Push Rivet	140038	Push Rivet SR-0817BK	3	N/A
25	Zip Tie	140053	Zip Tie, Lower Cable Guide	1	N/A
26	Skidplate	140077	Skidplate E7000 BLK, Recon Alloy	1	N/A
27	Battery Door	140078	Recon Alloy Battery Door	1	N/A
28	Rear Fender	140086	Rear Fender, Recon Alloy	1	N/A
29	Rear Rack Recon Alloy	160004	Rear Rack Recon Alloy, Blk, Rubis Rack, RU-9549	1	N/A
30	Clip Plastic	310001	Clip for Single Guide Plastic	3	N/A
31	Jagwire cable guide	310011	Jagwire cable guide CC1010AB, 2 guide	1	N/A
32	Cap with Hole	310012	Cap with Hole VLD-150	2	N/A
33	Grommet	310013	Jagwire CCN009-5, Plug Internal Frame Routing, 2.5 mm E-wire	1	N/A
34	Seat Clamp	340339	Seat Clamp Recon Alloy, GW #CSC0040	1	6 to 8 Nm / 53 to 70 in-lbs
35	Zerk Fitting M6 x 1.0	401011	Zerk Fitting M6 x 1.0	1	5 Nm / 45 in-lbs
36	SHCS M6 x 22	410009	SHCS, Socket Head, M6 x 22	3	14 Nm / 125 in-lbs
37	BHCS M5 x 12	410010	Bolt BHCS, Button Head, M5 x 12	2	2 Nm / 18 in-lbs
38	SHCS M8 x 35	410045	Bolt SHCS, M8 x 35 Steel	1	16 Nm / 140 in-lbs
39	SHCS M6 x 18	410048	SHCS, Socket Head, M6 x 18	2	14 Nm / 125 in-lbs
40	Low Profile M5 X 11	410068	Low Profile Head Screw, M5 x 11,2.5 Hex Black Recon Fender Screws Recon Skidplate Screws	2	(see below) 1 Nm / 9 in-lbs 2 Nm / 18 in-lbs



EXPLODED VIEW AND PARTS. RECON MX CONTINUED...

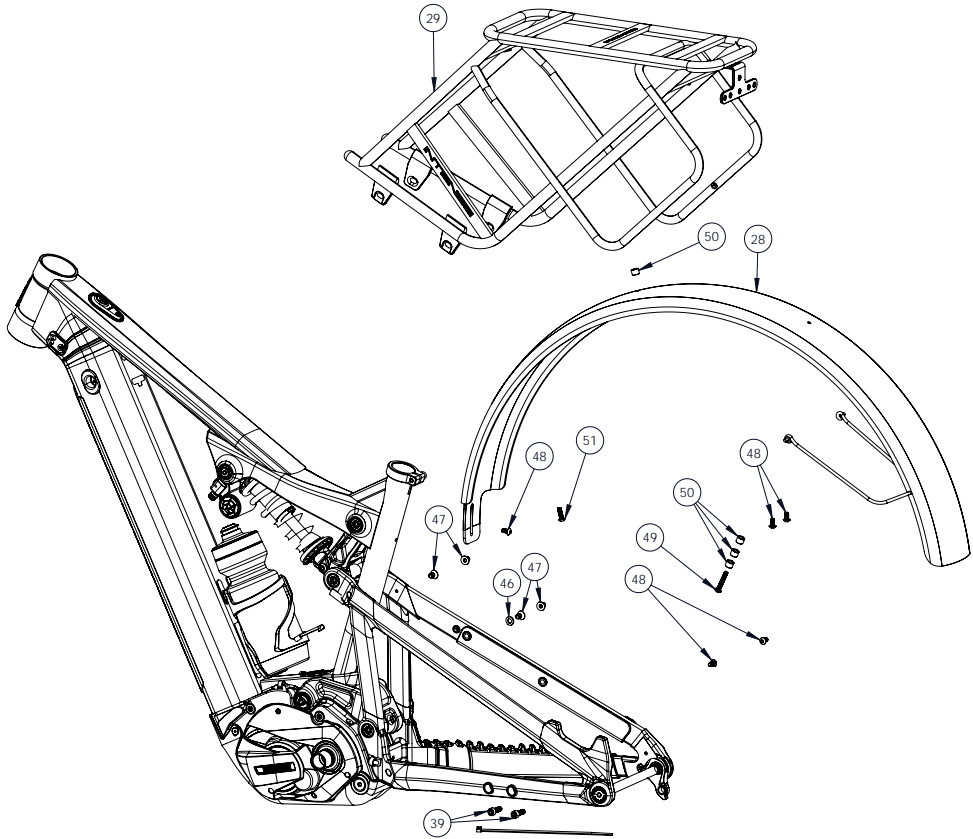

ITEM NO.	ITEM	PART NUMBER	DESCRIPTION	QTY.	TORQUE SPEC.
41	Hanger Hardware	410070	Hanger Stop, M4 x 8 x 10mm OD	1	2 Nm / 18 in-lbs
42	FHCS M4 x 12	410080	FHCS, Flat Head, M4 x 0.7 x 12 Stainless Steel	4	2 Nm / 18 in-lbs
43	Flat Washer	410081	M4 Flat Washer, Stainless Steel	8	N/A
44	Socket Head, M3 x 0.5	410082	SHCS, Socket Head, M3 x 0.5 x 6 Stainless Steel, Low Profile	3	1 Nm / 9 in-lbs
45	FHCS M4 x 0.7	410083	FHCS, Flat Head, M4 x 0.7 x 8, Black Oxide	4	3 Nm / 26 in-lbs
46	Washer	410085	Stainless Washer: $\Phi 12$ x $\Phi 6.5$ x 1.5mm	1	N/A

47	Flat Head Screw	410086	Flat Head Screw : M6 x P1.0 x 10mm	4	14 Nm / 125 in-lbs
48	BHCS M5 x 10	410087	Button Head Screw M5 x 10	5	2 Nm / 18 in-lbs
49	BHCS M5 x 30	410088	Button Head Screw M5 x 30	1	2 Nm / 18 in-lbs
50	Spacer	410089	YF 7.4mm Spacer Black, Fender Spacer	4	N/A
51	BHCS M5 x 16	410090	BHCS, Button Head Cap Screw: M5 x 16mm	1	2 Nm / 18 in-lbs
52	Bearing 7902	430007	7902-1ZS-MAX	2	N/A
53	Bearing 6802	430008	6802 LLU MAX	4	N/A
54	Bearing 6800	430011	6800 LLU MAX	2	N/A
55	Bearing 3802	430014	3802 LLU MAX, Double Row 15 x 24 x 7	2	N/A
56	Head Badge	500335	Head Badge Flame Logo	1	N/A
57	Flak Guard Chainstay	500524	Flak Guard Chainstay, Recon Alloy	1	N/A
58	Flak Guard Seatstay	500525	Flak Guard Seatstay, Recon Alloy	1	N/A
59	Flak Guard RT. Vert. Strut,	500526	Flak Guard RT. Vert. Strut, Recon Alloy	1	N/A
60	Clear Protector DT Cable	500530	Clear Protector, Recon Alloy DT Cable Protection	2	N/A
61	Clear Protector, RT Cable	500531	Clear Protector, Recon Alloy RT Cable Protection	2	N/A
62	Flak Guard CS	500532	Clear Protector, Recon Alloy RT UDH	1	N/A
63	Key Plug Grommet	500533	Key Plug Grommet, Recon Alloy	1	N/A
64	Battery BT-E8035L		Battery Mount BT-E8035L, 504 Wh	1	N/A
65	Switch: On/Off		EW_SW100	1	N/A
66	Charging Port		KEWCP100A Charging Port	1	N/A
67	Rear Shock		Recon MX Expert Rear Shock 185 x 55	1	N/A
68	Motor		Shimano E7000	1	N/A
69	Front Triangle		Recon Alloy Front Triangle: S/M, LG/XL	1	N/A
70	Rear Triangle for Rack		Recon Alloy Recon Rear Triangle	1	N/A
71	Water Bottle and Cage		Water Bottle 21 oz and Cage	1	N/A

RECON MX

## PARTS KITS

### LINK KIT LOWER HARDWARE

3	130778	Cap Bearing Blk TW
4	130785	Bolt Shoulder Fine Thread Blk TW
5	130795	Bolt Main Pivot 1.5T M16 Blk TW
7	130807	Spacer Cone Adjuster 8.3mm (Short) Blk TW
10	130850	Axle Lower Pivot
12	130860	Pivot Axle Spacer
24	140038	Plug Trim 15mm YF
35	401011	Zerk Fitting M6 x 1.0 x 7
36	410009	Bolt SHCS M6 x 22

### MOTOR MOUNT KIT

13	130862	Drive Unit Bolts M8 x 1.25 x 20 mm Length
15	130867	Skidplate Spacer
16	130868	M8 x 1.25 x 30 mm Skidplate Motor Bolt

### AXLE KIT REAR 148 X 12 BOOST

6	130799	Axle 148mm Boost BLK
---	--------	----------------------

### DERAILLEUR HANGER KIT (UDH)

19	130897	UDH Universal Derailleur Hanger SRAM 00-7918-089-000
41	410070	Hanger Stop M4 x 8 x 10mm OD

### GUIDE AND GROMMET KIT ZAE7

22	130912	Cable Routing Guide Plate 12-174-000
23	130913	Cable Guide Clamp DT Cables
30	310001	Clip for Single Guide Plastic
31	310011	Jagwire cable guide CC1010AB 2 guide
32	310012	Cap with Hole VLD-150
33	310013	Grommet Jagwire CCN009-5
45	410083	Fastener Flat Head M4 x .7 x 8 Black
63	500533	Key Plug Grommet

### SKIDPLATE KIT ZAE7

26	140077	Skidplate E7000 BLK
40	410068	Bolt SHCS Flat Head M5 x 11

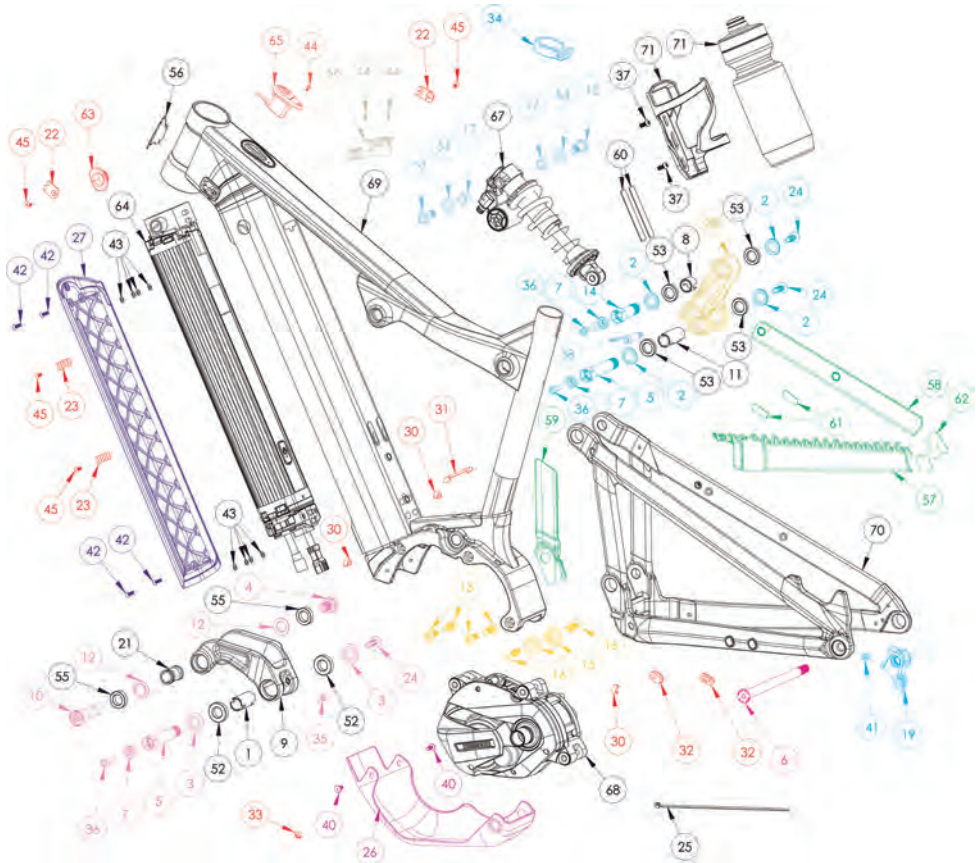

**FRAME PROTECTION KIT ZAE7**

**IT150164**

- |    |        |                                     |
|----|--------|-------------------------------------|
| 57 | 500524 | Flak Guard Chainstay                |
| 58 | 500525 | Flak Guard Seatstay                 |
| 59 | 500526 | Flak Guard RT. Vert. Strut          |
| 60 | 500530 | Clear Protector DT Cable Protection |
| 61 | 500531 | Clear Protector RT Cable Protection |
| 62 | 500532 | Clear Protector RT UDH              |

**LINK KIT UPPER HARDWARE**

**IT150167**

- |    |        |   |
|----|--------|---|
| 2  | 130765 | Cap Bearing 24mm OD S275C Blk             |
| 5  | 130795 | Bolt Main Pivot 1.5T Blk TW               |
| 7  | 130807 | Spacer Cone Adjuster 8.3mm (Short) Blk TW |
| 14 | 130863 | Collet Bolt Top Link/Ft Triangle Blk      |
| 24 | 140038 | Plug Trim 15mm YF                         |
| 36 | 410009 | Bolt SHCS M6 x 22                         |

RECON MX

# PARTS KITS CONTINUED...

<b>SEAT COLLAR KIT</b>	<b>IT150168</b>	
34	340339	Seat Clamp GW #CSC0040
<b>WHEEL SENSOR KIT E-7000</b>	<b>IT150200</b>	
AAOT000579/SP-SS10	SP-SS10	Speed Sensor Magnet for Brake Rotor
KSMDUE11A	KSMDUE11A	Speed Sensor Unit E7000
<b>DISPLAY UNIT KIT SC-E7000</b>	<b>IT150201</b>	
N/A	KSCE7000AG	Cycle Computer SC-E7000 Clamp Band Diameter 35.0MM
<b>BATTERY DOOR KIT ZAE7</b>	<b>IT150172</b>	
23	130913	Cable Guide Clamp DT Cables
27	140078	Battery Door
42	410080	Fastener Flat Head M4 x 0.7 x 12 Stainless
45	410083	Fastener Flat Head M4 x .7 x 8 Black
<b>SWITCH KIT ON/OFF</b>	<b>IT150202</b>	
44	410082	Fastener SHCS M3 x .5 x 6 Stainless
65	KEWSW100A	EW-SW100 On/Off Switch
<b>CHARGING PORT KIT</b>	<b>IT150175</b>	
44	410082	Fastener SHCS M3 x .5 x 6 Stainless
66	KEWCP100A	Satellite Charging Port EW-CP100 Cable Length To BM-E803X 200mm
<b>LINK KIT UPPER</b>	<b>IT150194</b>	
20	130904 B	Link Upper
<b>SHOCK MOUNT KIT</b>	<b>IT150196</b>	
17	130869	Spacer 10 mm Length, Trunnion Mount
18	130870	Bolt Shoulder 22.6 mm length, Trunnion Shock
38	410045	Bolt SHCS Button Head M5 x 8 x .8 Blk
54	430011	Bearing 6800 LLU MAX

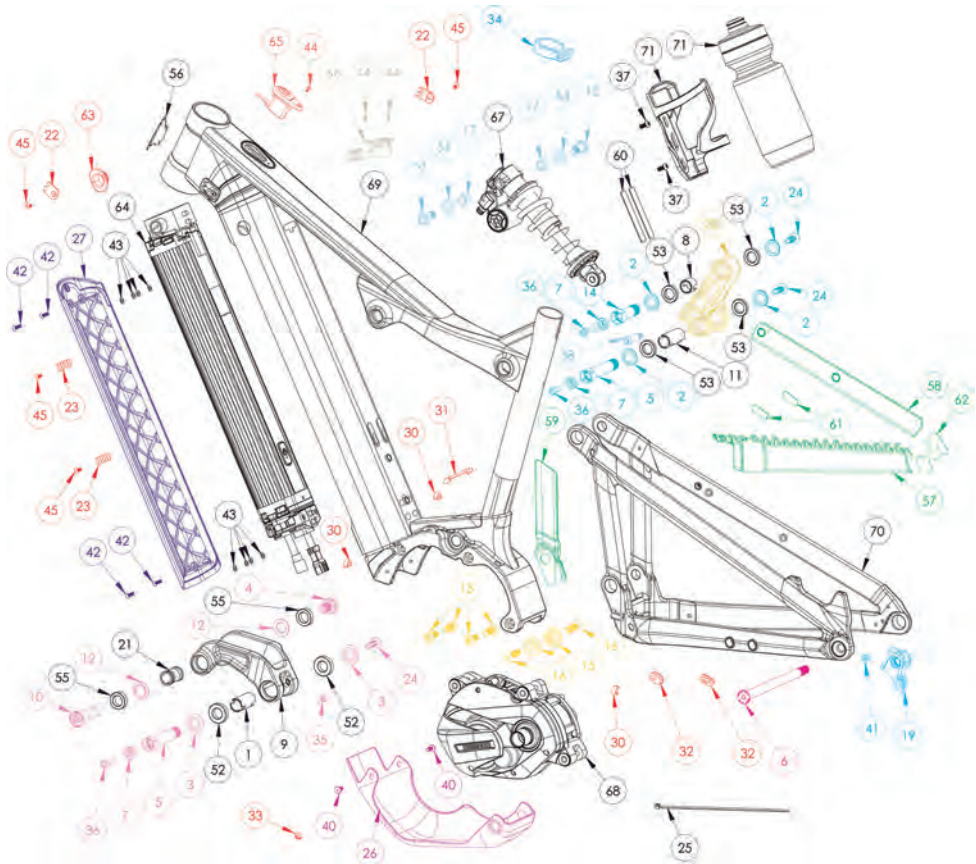



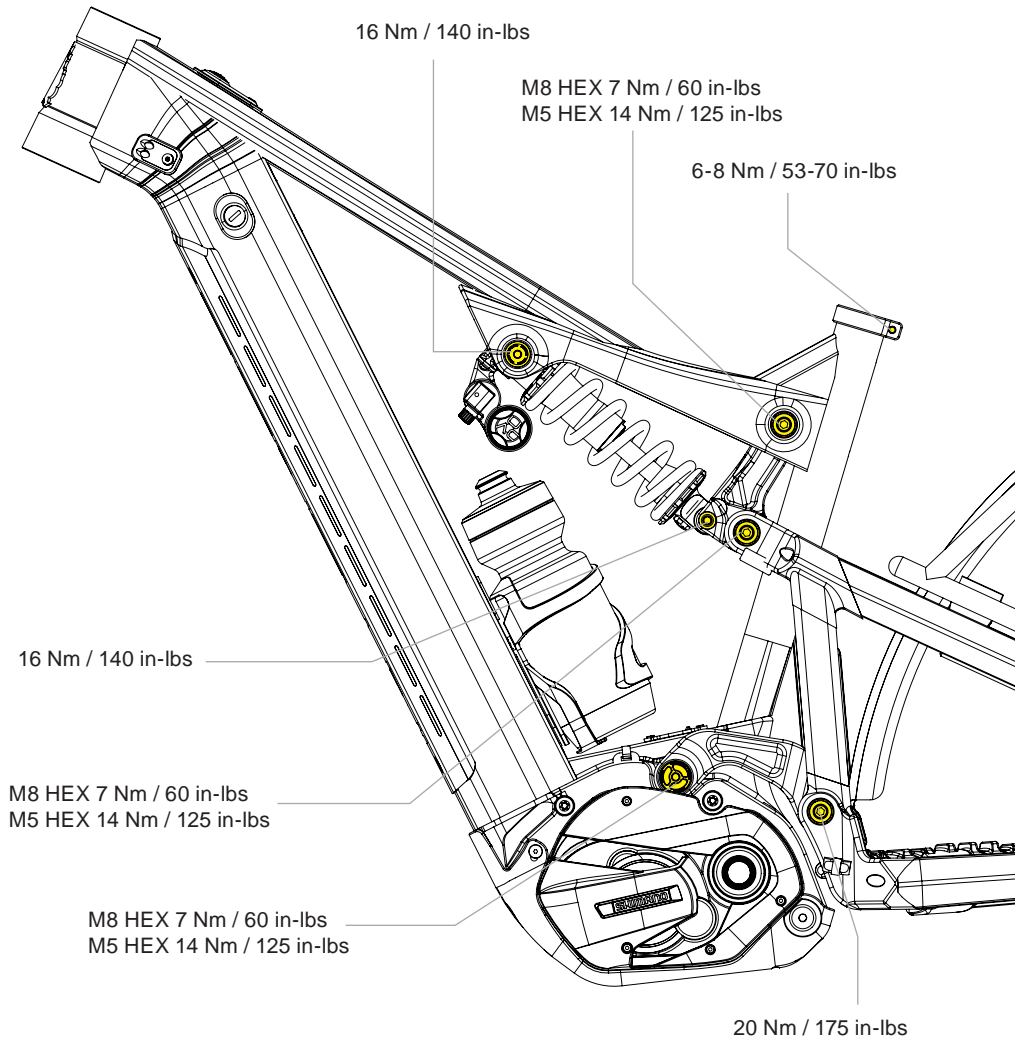

## TORQUE SPECIFICATIONS

Achieving correct torque is vital to ensuring the proper performance and function of the Recon MX frame. Failure to do so could result in suboptimal performance of your frame as well as premature wear and tear of individual parts. In addition to this chart, torque values are laser etched onto corresponding hardware for your reference.

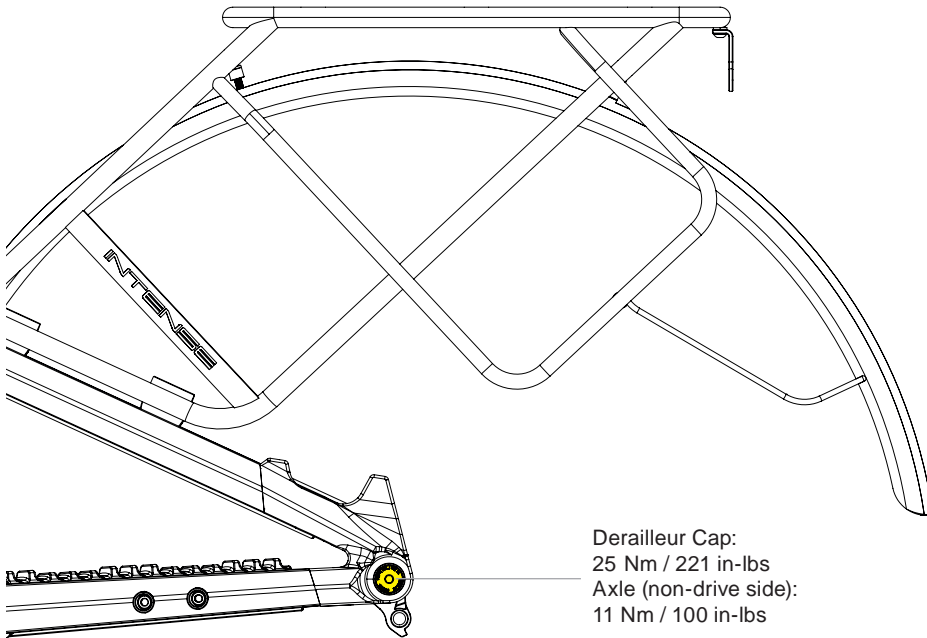

# DECLARATION OF CONFORMITY

Recon MX intended for Off-road Use.

## THE MANUFACTURER

**INTENSE, LLC**

42380 Rio Nedo

Temecula, CA 92590-3708, USA

TEL: 951-307-9211

## HEREBY CONFIRMS THE FOLLOWING PRODUCTS

Product Name:

INTENSE RECON MX e-Bike

Year of Construction: 2023

Conformity with all applicable provisions from the Machinery Directive (2006/42/EC). The machine conforms to all applicable provisions of the Directive 2014/30/EU Electromagnetic Compatibility Directive.

## These standards were applied:

EN 15194: 2017 Bicycles:

Electrically power assisted bicycles, EPAC Bicycles.

ISO 4210-2 Bicycles: Safety requirements for bicycles.

## Technical documentation from:

INTENSE, LLC

42380 Rio Nedo

Temecula, CA 92590-3708, USA

TEL: 951-307-9211

## Place and Date of issue of this Declaration of Conformity:

Temecula, CA, April 1, 2023

**Jeff Steber**

CEO/Founder

**Corey Hsu**

Managing Director of Asia Operation

**Thomas Harter**

Engineering Director

SEED

**Chris Knutson**

Engineer

This declaration of conformity is specific to countries following CE marking directives.

## ***NEED HELP?***

For additional support, please visit [www.intensecycles.com](http://www.intensecycles.com) where you will find information regarding registration, warranty, part replacement as well as a variety of useful videos that will help you set up and keep your bike in optimal riding condition.

[www.intensecycles.com](http://www.intensecycles.com)

**Phone:**

+1 (951) 307 9211

**Customer Service:**

[techcenter@intensecycles.com](mailto:techcenter@intensecycles.com)

**General Info:**

[info@intensecycles.com](mailto:info@intensecycles.com)

**INTENSE LLC**

42380 RIO NEDO  
TEMECULA, CA 92590  
USA

INTENSE



RECON MX

# MANUAL

RECON MX  
08 245 22  
MAXXIS  
EDUARD  
MAXXIS