

LENOX TRAY HITCH RACK ASSEMBLY INSTRUCTIONS

WARNING & CAUTION

Improperly installed rack or bikes can fall onto roadway potentially causing a serious accident resulting in bodily injury. Do not use rack on any vehicle where the rack cannot be properly and safely installed. Max weight: 2 bike rack = 80lbs / 36kgs. Do not exceed.

- Only install rack on vehicles with a 1 ¼" (Class II) or 2" (Class III) receiver hitches.
- Never use on trailers, RV's, hitch adapters, or front of vehicle.
- Bikes must be secured to the rack using the trays, supplied tie-downs and additional straps if necessary (not supplied).
- Check regularly during use that all bicycles remain secured and all bolts and pins are tight and secured.
- Bicycle tires should not be placed directly in front of an exhaust pipe. Tires can melt.
- Not safe for Tandem Bikes, Recumbent Bikes, Motorized Bikes, or other non-standard bikes.
- Do not block tail-lights or other car lights with bikes.
- Drive carefully. Drive slowly over bumps. Do not Drive off-road.

- Be aware that the rear of the vehicle is much longer when the rack is installed and needs additional clearance when moving in reverse.
- Do not use the rack if any parts are missing. Contact Retrospec for replacement parts.
- Bikes should never extend beyond side of vehicle.
- Stow carry arms or remove rack when not in use.
- Never mount the rack on the front of a vehicle. Mounting the rack on the front of a vehicle can obstruct the headlights, directional lamps, and your forward visibility creating an unsafe driving condition.
- This rack is only intended to be installed on a vehicle with a receiver hitch that is attached to the vehicle's frame.

ASSEMBLY INSTRUCTIONS

** PLEASE READ INSTRUCTIONS ENTIRELY BEFORE BEGINNING ASSEMBLY **

STEP 1: UNPACKING CONTENTS

1 - Unpack the contents of your bike carrier and lay the parts out on a flat surface (Fig. 1).

MAIN PARTS:



- A: **1 x** Main Support Hub with 1 - Main Center Mast (vertical) factory installed (with 3 Push Pins - leash-attached)
- B: **2 x** Wheel Tray Support Beams (horizontal)
- C: **4 x** Wheel Trays with 4 rubber straps
- D: **1 x** Hitch Tongue 1 ¼"
- E: **2 x** Ratcheting Lock-Down Hooks (1- long, 1-short)
- F: **1 x** 2" Receiver Adapter

HARDWARE:

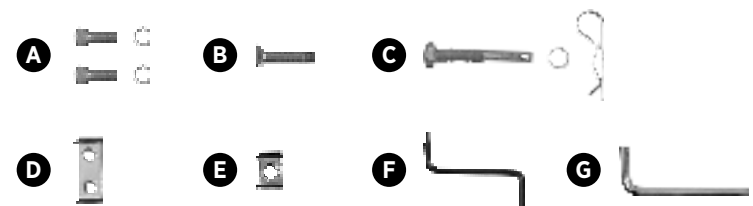

- A: **2 x** 1 ¼" length x 8mm hex head bolts with 2 lock washers (to secure Hitch Tongue to Main Support Hub)
- B: **1 x** 2" length x 6mm hex head Flush-Mount Bolt (for 2" Adapter)
- C: **1 x** 3 ½" half-thread Anti-Rattle Hitch Bolt with lock washer + Hairpin Cotter Pin
- D: **1 x** 2-Hole Anti-Rattle Threaded Plug (for Hitch Tongue to Main Support Hub)
- E: **1 x** 1-Hole Anti-Rattle Threaded Plug (for Hitch Bolt into Vehicle Receiver)
- F: **1 x** 6mm hex wrench
- G: **1 x** 8mm hex wrench

STEP 2: HITCH TONGUE TO MAIN SUPPORT HUB

1. Align and insert 2-Hole Anti-Rattle Threaded Plug into Hitch Tongue (end with 2 closely spaced/same size holes **(Fig. 2)**).
2. Align and insert the 2-Hole Hitch Tongue with Plug inserted into the Main Support Hub **(Fig. 3)**.
3. Install the two 1 1/4" x 8mm hex head mounting bolts with lock washers into the bottom of the rack base and tighten firmly **(Fig. 4)**.

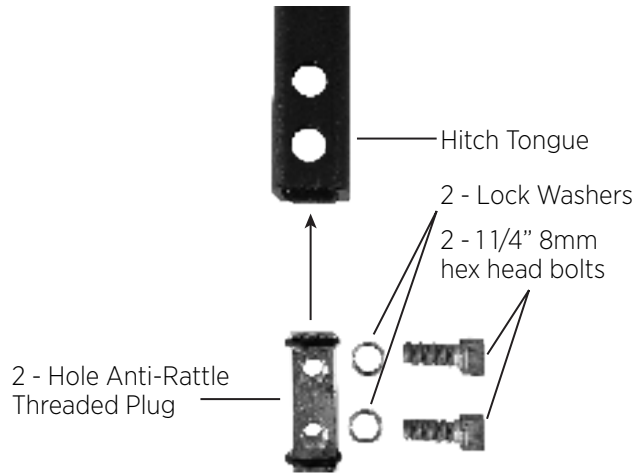

Fig. 2



Fig. 3

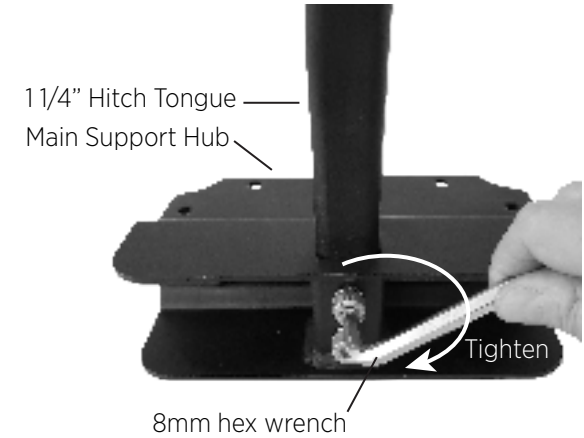

Fig. 4

STEP 3: WHEEL SUPPORT BEAMS

1. Slide the two Wheel Tray Support Beams into the horizontal square slots, secure with Push Pins **(Fig. 5)**.
2. Slide the Wheel Trays onto the beam making sure to alternate one pair to the left and one pair to the right of each other to allow for adjustment for individual bike wheel bases **(Fig. 6 & 7)**.

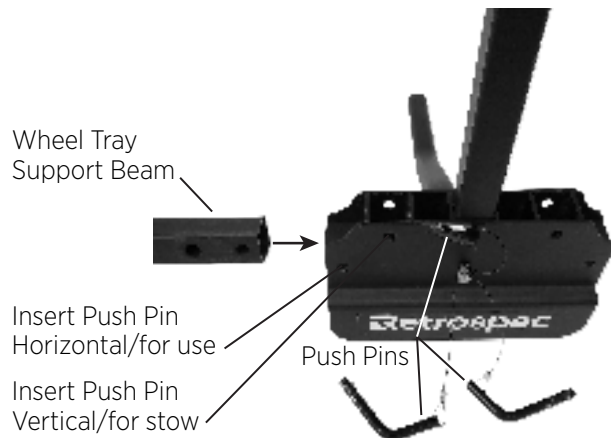

Fig. 5



Fig. 6



Fig. 7

STEP 4: RECEIVER ADAPTER

1 ¼" RECEIVER:

1. Rack is factory-ready for installation into 1 ¼" (Class II) vehicle hitch receiver.
2. Align and insert 1-Hole Anti-Rattle Threaded Plug to large hole at end of Hitch Tongue (similar to STEP 2) (**Fig. 8**).

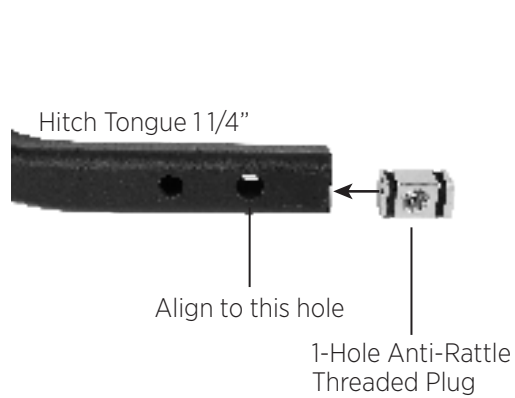

Fig. 8

2" RECEIVER:

1. Align and install 2" length x 6mm hex head Flush-Mount Bolt through 2" Adapter Sleeve into smaller/second hole from end of the Hitch Tongue. Tighten firmly (**Figs. 9 & 10**).
2. Align and insert 1-Hole Anti-Rattle Threaded Plug to large hole at end of Hitch Tongue (similar to STEP 2) (**Fig. 10**).

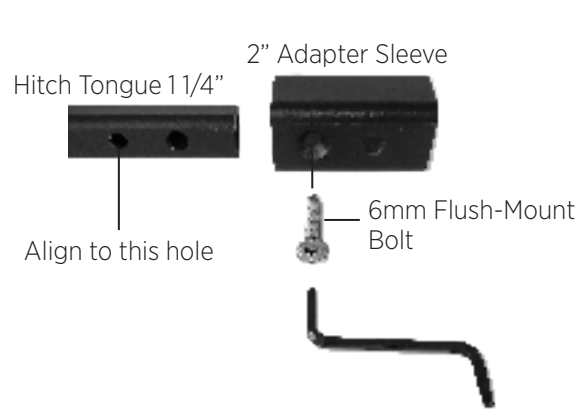

Fig. 9

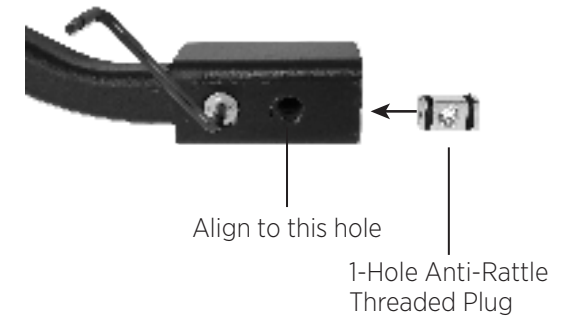

Fig. 10

STEP 5: RACK ON VEHICLE

1. With 1-Hole Anti-Rattle Threaded Plug installed and aligned, insert rack onto vehicle by sliding the Hitch Tongue into the hitch receiver (**Fig. 11**).
2. Insert 3 ½" half-thread Anti-Rattle Hitch Bolt (19mm) with lock washer into receiver and tongue and tighten securely (**Fig. 12**).
3. Insert Hairpin Cotter Pin through hole on other side of hitch bolt (**Fig. 13**).

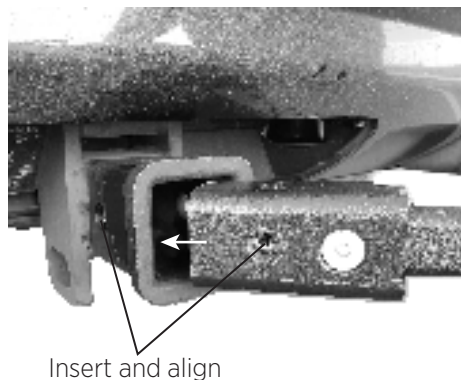

Fig. 11



Fig. 12

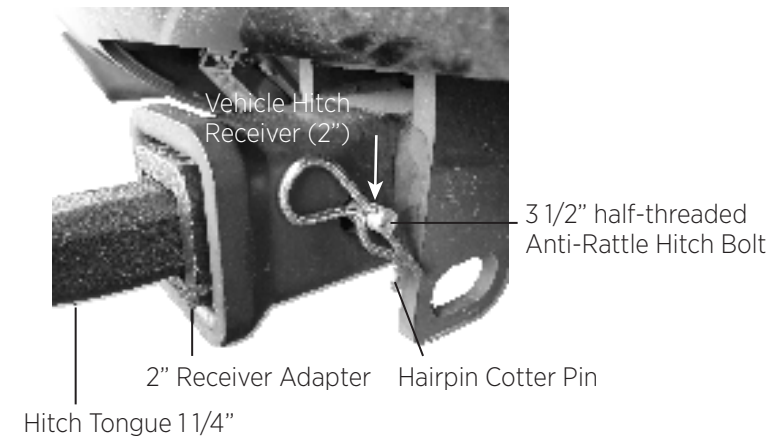

Fig. 13

STEP 6: RATCHING LOCK-DOWN HOOKS

1. Locate the 2 – Ratcheting Lock-Down Hooks. These hooks ratchet down the vertical Center Mast and secure the frame(s) of the bicycle(s) to the rack **(Fig. 14)**.
 - a. Notice that one arm is longer than the other. This allows you to accommodate different sizes and styles of frames.
 - b. To raise the arms up and away from the frame or remove them from the central beam, press the button(s) located on the side of the arm bracket to release the hook from the Center Mast.

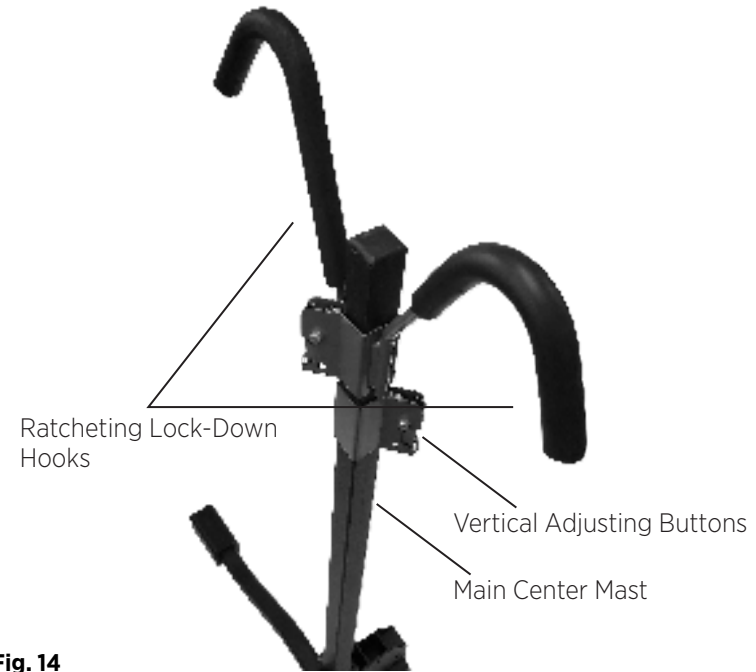

Fig. 14

STEP 7: BIKES ON RACK

1. Adjust the wheel tray locations to match the wheelbase of your bikes.
2. Tighten thumb knobs on each wheel tray to prevent them from moving out of place or vibrating off while driving.
3. Load the bikes onto the rack with the handlebars facing in opposite directions from each other to avoid interference between bikes.
4. Lower Ratcheting Lock-Down Hooks onto the frame of each bike, pressing firmly, so bike(s) is secure on the rack.
5. Secure each bike wheel to the tray using rubber straps on each wheel tray. **Fig. 15** for procedure 1-5.



Fig. 15

RETROSPEC ACCESSORY HITCH CARRIER LIMITED WARRANTY

Retrospec grants the original purchaser of a new Retrospec accessory hitch carrier a non-transferable limited lifetime warranty subject to the limitations, terms and conditions stipulated below.

TERMS & CONDITIONS:

- The product is warranted against defects in the materials and workmanship for the useful life cycle of the product. All products have a useful life cycle. Once the product has reached the end of its lifecycle it will no longer be eligible for warranty replacement or adjustments.
- This warranty applies to the original retail purchaser and is non-transferable. When contacting us for a warranty issue an original proof of purchase is required clearly identifying the product.
- The product must be returned to Retrospec for inspection along with copies of the original proof of purchase. The owner of the product is responsible for shipping costs.
- Should Retrospec determine that the product or any of its components are covered by this warranty, Retrospec's determination of the product's eligibility for warranty repair or replacement is final and binding.
- If, at the time of replacement, Retrospec does not have available the same product, the consumer may be offered a substitute product of equal or better value.

ITEMS NOT COVERED BY THE LIMITED WARRANTY:

- Damage due to improper assembly
- Damage due to mounting the rack on the back of a trailer, Recreational vehicles, or to bumper hitch adapters.
- Normal wear and tear
- Damage due to lack of maintenance
- Damage due to installation of non-original parts, components, or accessories
- Damage due to loading of the bicycle carrier with non-standard bicycles, items that are not standard bicycles, or any product that exceeds the stated weight capacity of the bicycle carrier.
- Damage or failure due to improper use, accidents, neglect, or failure to follow the instructions provided with the product.
- The paint and finish of the bicycle carrier.
- Damage to bicycles or automobile
- Damage or injury due to the rack or bicycles falling from the car.

This warranty is expressly in lieu of all other warranties. Any implied warranties of merchantability or fitness for a particular purpose created hereby are limited to the same duration as the express warranty herein. This warranty is void in its entirety if the product is modified in any manner. All provisions in this limited warranty are separate and severable. If any provision is held invalid and unenforceable, such determination shall not affect the validity or enforceability of the other provisions hereof. Except to the extent specifically prohibited by law, Retrospec shall in no way be responsible for direct, incidental or consequential damages, including, without limitation, damages for personal injury, property damage, or economic losses whether based on contract, warranty, negligence, product liability, or any other theory.