

PACIFIC

AUTO CLEAN

抽油煙機 使用說明書



抽油機型號: AC3300BS / AC3336BS / AC3342BS

序 號: _____

(使用前，請先詳細閱讀此說明書)

XP022522(3)

PACIFIC

AUTO CLEAN

OPERATING INSTRUCTION



Model number: AC3300BS / AC3336BS / AC3342BS

Serial Number: _____

Read all instructions before operating the range hood.

XP022522(3)

IMPORTANT SAFETY NOTICE

READ AND SAVE THESE INSTRUCTIONS

WARNING

TO REDUCE THE RISK OF FIRE OR ELECTRIC SHOCK, DO NOT USE THIS FAN WITH ANY SOLID-STATE CONTROL DEVICE.

WARNING

TO REDUCE THE RISK OF FIRE, ELECTRIC SHOCK, OR INJURY TO PERSONS, OBSERVE THE FOLLOWING:

- a) Use this unit only in the manner intended by the manufacturer, if you have questions, contact the manufacturer.
- b) Before servicing or cleaning unit, switch power off at service panel and lock the service disconnecting means to prevent power from being switched on accidentally. When the service disconnecting means cannot be locked, securely fasten a prominent warning device, such as a tag, to the service panel.

CAUTION

For General Ventilating Use Only. Do Not Use To Exhaust Hazardous Or Explosive Materials And Vapors.

WARNING -

TO REDUCE THE RISK OF A RANGE TOP GREASE FIRE:

- a) Never leave surface units unattended at high settings. Boil overs cause smoking and greasy spillovers that may ignite. Heat oils slowly on low or medium settings.
- b) Always turn hood ON when cooking at high heat or when flaming food.(i.e.Cherries Jubilee, Peppercom Beef Flambe').
- c) Clean ventilating fans frequently. Grease should not be allowed to accumulate on fan or filter.
- d) Use proper pan size. Always use cookware appropriate for the size of the surface element.
- e) Keep fan, filters and grease laden surfaces clean.
- f) Use high setting on hood only when necessary.
- g) Don't leave hood unattended when cooking.
- h) Always use cookware and utensils appropriate for the type of and amount of food being prepared.

WARNING -

TO REDUCE THE RISK OF INJURY TO PERSONS IN THE EVENT OF A RANGE TOP FIRE, OBSERVE THE FOLLOWING:

- a) SMOTHER FLAMES with a close-fitting lid, cookie sheet, or metal tray, then turn off the burner. BE CAREFUL TO PREVENT BURNS. If the flames do not go out immediately, EVACUATE AND CALL THE FIRE DEPARTMENT.
- b) NEVER PICK UP A FLAMING PAN – You may be burned.
- c) DO NOT USE WATER, including wet dishcloths or towels – a violent steam explosion will result.
- d) Use an extinguisher ONLY if:
 - 1) You know you have a Class ABC extinguisher, and you already know how to operate it.
 - 2) The fire is small and contained in the area where it started.
 - 3) The fire department is being called.
 - 4) You can fight the fire with your back to an exit

WARNING -

TO REDUCE THE RISK OF FIRE, ELECTRIC SHOCK OR INJURY TO PERSONS, OBSERVE THE FOLLOWING:

目錄

一. 功能簡介/性能規格表	1
二. 配件說明	2
三. 安裝原則	3
四. 安裝步驟	4
五. 按鍵說明	5
六. 機身表面保養和清潔	6
七. 注意事項	7
八. 排除故障	8

- a) Installation work and electrical wiring must be done by qualified person(s) in accordance with all applicable codes and standards. Including fire-rated construction.
- b) Sufficient air is needed for power combustion and exhausting of gases through the flue (chimney) of fuel burning equipment to prevent back-drafting. Follow the heating equipment manufacturer's guideline and safety standards such as those published by the National Fire Protection Association (NFPA) and the American Society for Heating, Refrigeration and Air Conditioning Engineers (ASHRAE) and the local code authorities.
- c) When cutting or drilling into wall or ceiling, do not damage electrical wiring and other hidden utilities.
- d) Ducted fans must always vent to the outdoors.
- e) NEVER place a switch where it can be reached from a tub or shower.
- f) Make sure the power is off before installing, wiring or maintenancing.

WARNING

TO REDUCE THE RISK OF FIRE, USE ONLY METAL DUCTWORK.

CAUTION

To reduce risk of fire and to properly exhaust air outside - Do not vent exhaust air into spaces within walls, ceilings, attics, crawl spaces or garages.

OPERATION

Always leave safety grilles and filters in place. Without these components, operating blowers could catch onto hair, fingers and loose clothing.

The manufacturer declines all responsibility in the event of failure to observe the instructions given here for installation, maintenance and suitable use of the product. The manufacturer further declines all responsibility for injury due to negligence and the warranty of the unit automatically expires due to improper maintenance.

ELECTRICAL REQUIREMENTS

Important: Observe all governing codes and ordinances.

It is the customer's responsibility:

- To contact a qualified electrical installer.
- To assure that the electrical installation is adequate and in conformance with National Electrical Code, ANSI/NFPA 70 latest edition* or CSA standards C22.1-94, Canadian Electrical Code, Part 1 and C22.2 No.0-M91 - latest edition** and all local codes and ordinances.

If codes permit and a separate ground wire is used, it is recommended that a qualified electrician determine that the ground path is adequate.

Do not ground to a gas pipe.

Check with a qualified electrician if you are not sure the range hood is properly grounded.

Do not have a fuse in the neutral or ground circuit.

*National Fire Protection Association Batterymarch Park, Quincy, Massachusetts 02269

** CSA International 8501 East Pleasant Valley Road, Cleveland, Ohio 44131-5575

This appliance requires a 120V 60Hz electrical supply and connected to an individual properly grounded branch circuit protected by a 15 or 20 ampere circuit breaker or time delay fuse. Wiring must be 2 wire with ground. Please also refer to Electrical Diagram on product.

A cable locking connector (not supplied) might also be required by local codes.

Check with local requirements, purchase and install appropriate connector if necessary.

一. 功能簡介/性能規格表

A. 產品功能

1. 具有一按完成(38秒程式) 自動清洗內部功能。
獨特之處：突破性科技為現代家庭帶來“完全方便”的排油煙機，免拆免裝，一按即可自動清洗，省卻所有清洗排油煙機的煩惱。
2. 具有延遲關機功能。
3. 具有一按開關功能。
4. 微電腦程式操控。
5. 按鍵功能：電源/延遲關機、風扇低速、風扇高速、自動清洗、照明。

B. 規格表

型 號	AC3300BS	AC3336BS	AC3342BS
重 量 (Kg)	15.1 kgs	16.6 kgs	17.8 kgs
尺 寸 (mm)	565.5X180X755mm	565.5X180X907mm	565.5X180X1059 mm
最大伏特數	120 V – 60 Hz		
風 管 直 徑	6 吋		
燈 泡	4W LED燈泡x1		
最大消耗功率	2A / 240W		

二. 配件說明

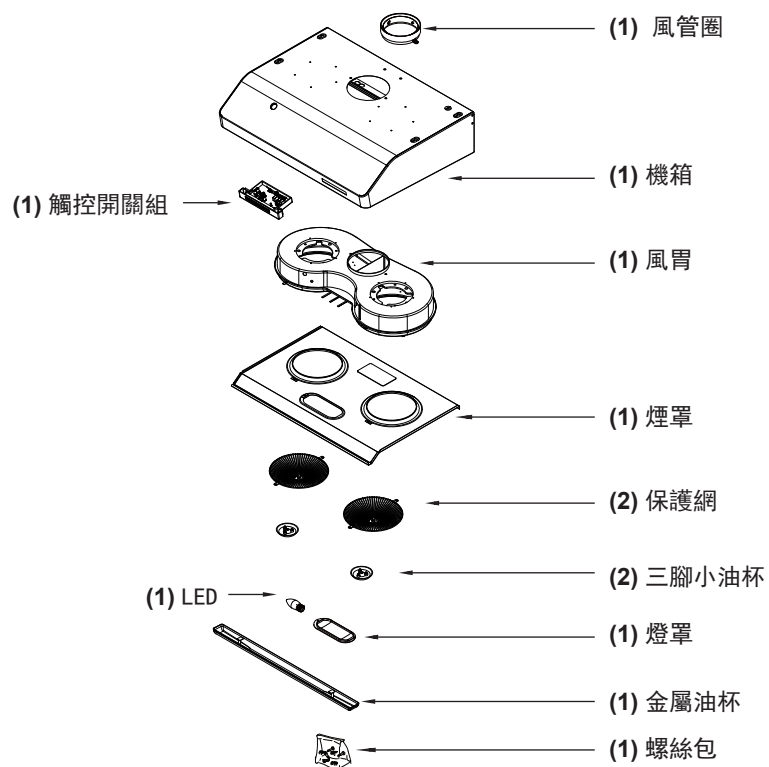

螺絲包配件：(美國地區)

序號	圖示	種類	數量
A		P3螺母	3
B		5 x 12 x 1T 華司	4
C		6# x 2吋木螺絲	4
D		6# x 1-1/2吋木螺絲	4
E		6# x 1吋木螺絲	4
F		掛勾組	2
G		3/16 x 1/2吋華司頭螺絲	4

螺絲包配件：(加拿大地區)

序號	圖示	種類	數量
A		P3螺母	3
B		5 x 12 x 1T 華司	4
C		6# x 2吋木螺絲	4
D		6# x 1-1/2吋木螺絲	4
E		6# x 1吋木螺絲	4

Table of Content

I. Product Functions/Performance Specification Chart	1
II. Parts Supplied	2
III. Installation Guidelines	3
IV. Installation Procedures	4
V. Operating Instructions	5
VI. Surface Maintenance	6
VII. Remarks	7
VIII. Troubleshooting	8

I. Product Functions/Performance Specification Chart

A. Product Functions

1. One touch automatic internal cleaning function (in 38 seconds).
Characteristics: this pioneered technology brings total convenience to modern families.
This automatic cleaning function can simply be done by one touch function without disassembling the machine.
2. Delay off Button.
3. One touch On/Off Button.
4. Micro-Computer Programmed functions.

B. Specification Chart

Models	AC3300BS	AC3336BS	AC3342BS
Weight(Kg)	15.1 kgs	16.6 kg	17.8 kgs
Measurement(mm)	565.5x180x755 mm	565.5x180x907 mm	565.5X180X1059 mm
Maximum Voltage	120 V – 60 Hz		
Exhaust Pipe Diameter	6 inches		
Light	4W LED Bulb x1		
Maximum Consumption Power	2A / 240W		

三. 安裝原則

1. 周圍環境(圖一):

抽油煙機安裝位置，如在窗上或附近有太多門窗，請在開動抽油煙機前，先關閉門窗，以免空氣對流大而影響吸力，因當油煙上昇未至10吋之有效吸力範圍，則無法充分發揮抽油煙最佳效果。

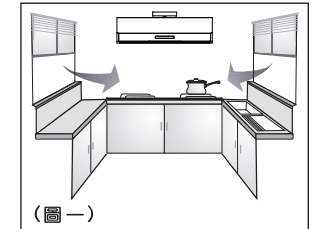

(圖一) 門窗太多、對流太大

2. 安裝高度(圖二):

安裝高度自本機底板至煮食爐面之距離以24~30吋為最理想。

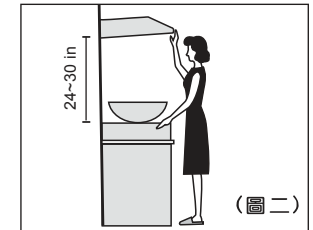

(圖二)

3. 機體應保持水平(圖三):

機體應保持前、後、左、右水平，以免氣流箱，導油盆積油而溢出。
左、右水平可由掛碼調整，前、後水平則由鋼丁螺絲鎖緊牆壁，以固定標準。

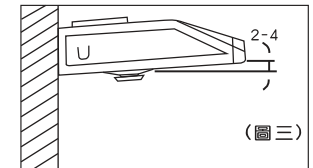

(圖三)

4. 排風管:

為增加吸力效能，請配合使用本機出風管接頭之直徑6吋排風管，排風管長度應以適合長度最佳，不宜過長。

5. 插座安排:

請勿與烤箱或冰箱等耗電量較高之電器產品共用一個插座。

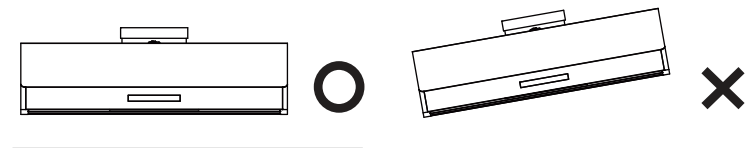

※ 安裝前先以矽利康注入風管圈後將風管嵌入，再用封膠封住風管圈。

四. 安裝步驟

1. 請準備安裝位置及空間(上出風)。
2. 測量出風口及電源線孔的大小，然後再鑽孔。
備註：出風口尺寸應要足以安裝鋁製風管。
3. 櫥櫃需加強本機固定的地方，建議使用木條強化在櫥櫃內底部。
4. 請用十字螺絲起子移除油機底板，卸下油機底板。
5. 依安裝位置設置四支木螺釘。
6. 安裝時用木螺釘扣上之後，將油機與櫥櫃用螺絲鎖緊，確保油機穩固的安裝在櫥櫃上不會掉落。
7. 裝設電源。
8. 安裝風管並用風管膠帶密封。
9. 檢查風管處是否緊密及其他功能是否正常。
10. 將油機底板與燈泡重新安裝至油機。
11. 將油杯與出風口保護網重新安裝至油機。



圖 1

II. Parts Supplied

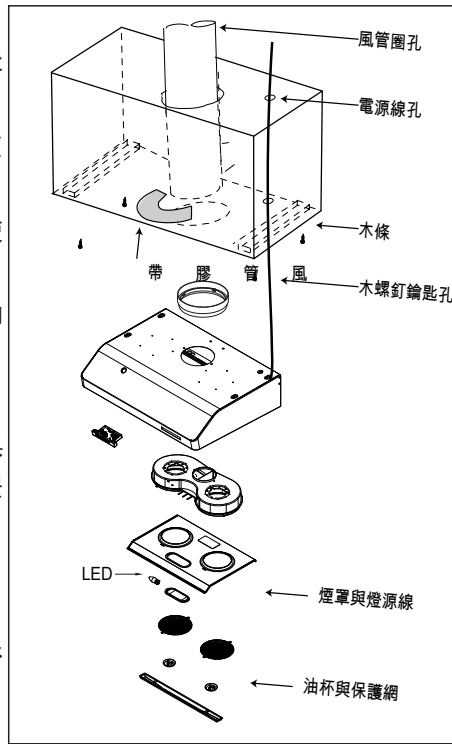
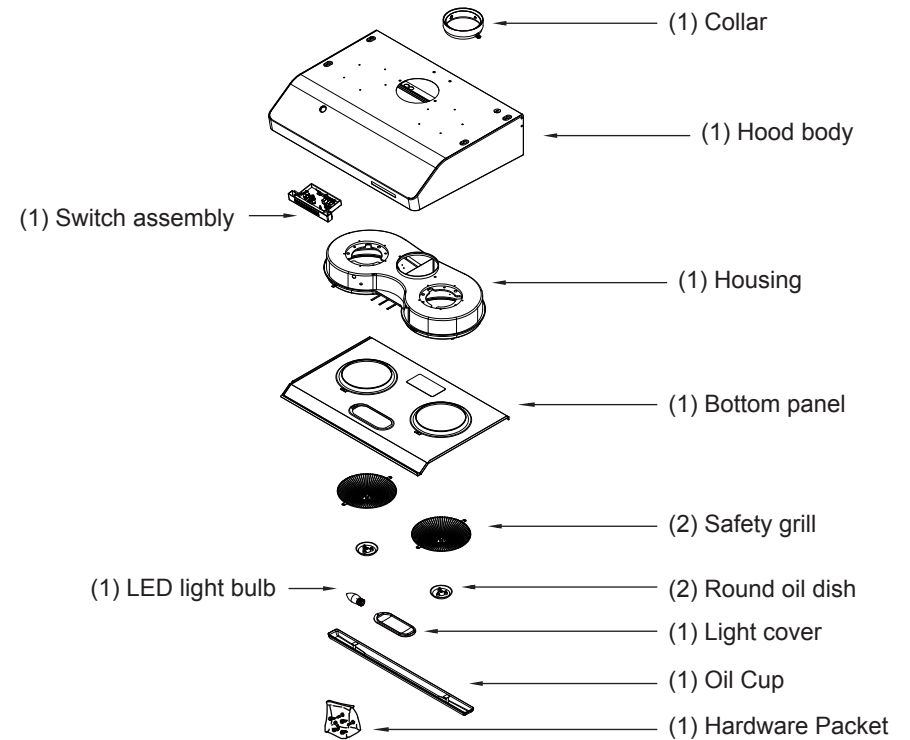

HARDWARE PACKAGE CONTENTS (For USA)

TYPE		DESCRIPTION	Q'ty
A		P3 Wire nuts	3
B		5 x 12 x 1T Washers	4
C		6# x 2" Wood screw	4
D		6# x 1-1/2" Wood screws	4
E		6# x 1" Wood screws	4
F		Wall Bracket	2
G		3/16 x 1/2" screws	4

HARDWARE PACKAGE CONTENTS (For Canada)

TYPE		DESCRIPTION	Q'ty
A		P3 Wire nuts	3
B		5 x 12 x 1T Washers	4
C		6# x 2" Wood screw	4
D		6# x 1-1/2" Wood screws	4
E		6# x 1" Wood screws	4

III. Installation Guidelines

1. Surrounding Environment (Fig.1)

Check the surrounding of range hood. If there are too many windows or doors nearby, it is advisable to close the windows and doors before turning on the range hood to prevent the external convection and affecting the ventilation.

The smoke has to rise up to 10 inches from the stove/grate to be within the range of venting efficiency.

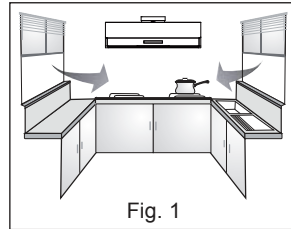

Too many windows, too much convection

2. Installation Heights (Fig.2)

The ideal installation height is a distance of 24 to 30 inches from the bottom of the range hood to the surface of the stove top.

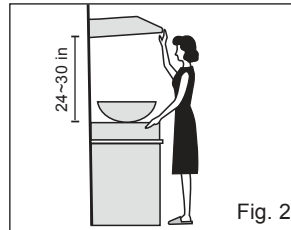

3. Hood installed in parallel and horizontal level (Fig.3)

The front, back, right and left of hood must be in parallel and horizontal level, to avoid the oil in the oil tub from spilling over. To ensure that the hood is leveled when installing, it can be measured by the hook mark for the left and right side; and the screws fixed securely onto the wall to ensure the front and back of the hood are parallel.

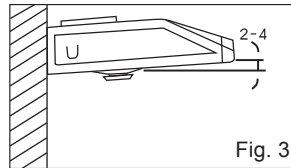

4. Exhaust duct

In order to increase the venting efficiency of the hood, it is recommended to use the 6 inch duct to maintain the best air flow efficiency; the length of duct must also be as minimal as possible.

5. Electrical arrangement

Please do not plug the range hood to the circuit breaker with other high electricity consumption appliances.



※ Before installing the hood, please apply fast drying glue to the collar and securely attach it to the top of the range hood's vent lid. Install the range hood and attach pipe to the plastic collar and seal with aluminum tape and prevent steam and smoke leakage.

五. 按鍵說明



1. “電源/延遲關機”按鍵

- (1) 輕按按鍵開啟或關閉排油煙機。
- (2) 初次啟動時，風速預設為低速，照明全亮。
- (3) 再次啟動時，會自動記憶前次使用之風速及照明段數。
- (4) 排油煙機開啟時，輕按此鍵關閉油煙機所有動作。
- (5) 排油煙機開啟時，長按三秒可啟動五分鐘延遲關機功能。延遲關機功能進行時，此鍵下方LED指示燈會開始閃爍，風扇自動低速運轉、照明段數不變，延遲關機功能進行期間可調整風速及照明，五分鐘後風扇及照明會自動關閉。
- (6) 延遲關機啟動狀態下，輕按此鍵關閉油煙機和延遲關機功能。

2. “風速減速”按鍵

- (1) 每按一次則速度遞減，至最低速為止。

3. “風速加速”按鍵

- (1) 每按一次則速度遞增，至最高速為止。

4. “自動清洗”按鍵

- (1) 輕按此鍵可啟動清洗功能。清洗功能啟動時，按鍵下方LED指示燈會亮起；再按一次自動清洗功能鍵或電源/延遲關機功能鍵則終止自動清洗。
- (2) 延遲關機功能進行時，此按鍵無效。
- (3) 風扇運轉時，按此鍵無效。
- (4) 馬達運轉每30小時，此按鍵下方指示燈會閃爍提醒。長按此鍵3秒可解除30小時清洗提醒。

5. “照明”按鍵

- (1) 輕按此鍵可開啟或關閉照明，不影響風速。當開啟照明，按鍵下方兩個指示燈會亮起。

六. 機身表面保養和清潔

一. 機身表面保養

1. 請定期以熱肥皂水和棉布擦拭機身以防油垢堆積。
2. 請勿使用腐蝕性洗碗精和材質過粗的布料擦拭，以免傷害到機身表面。
3. 擦拭完成後建議使用無刺激性的不鏽鋼拋光劑來進行第二次擦拭。
4. 請使用軟布輕擦，您的油煙機表面將會更加光亮。
5. 請勿使用含有漂白成分的清潔液。

二. 保養和清潔

1. 清潔前，務必要切斷電源。
2. 定期清潔抽油煙機的內外側，可以保持抽油煙機壽命，切勿使用研磨性清潔劑。
3. 使用螺絲起子移除保護網的螺絲後，可將保護網取下做清潔。完成清潔後，必須重新鎖回保護網。
4. 按逆時針方向旋轉(即反轉)，可取下保護網的小油碟並做清潔。完成清潔後，必須重新裝回小油碟。
5. 抽油煙機中央的小油碟可拆下做定期清潔。
6. 在開啟煮食爐前，請先開啟抽油煙機以免廚房溫度太高。

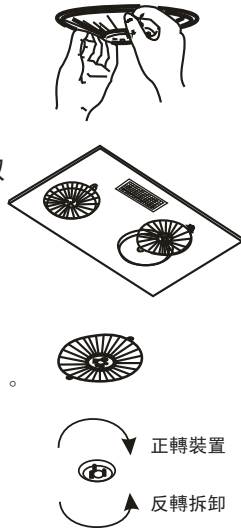

IV. Installation Procedures

1. Prepare duct location on hood (vertical).
2. Measure and cut out duct and electrical openings in cabinet or wall to match up with the hood. Ducting and electrical dimensions can be found on Page 1.
Note: Make sure duct opening is large enough to apply aluminum duct tape.
3. Reinforce cabinet bottom with wood strips if additional strengthening is required or if cabinets are framed.
4. Remove bottom panel from hood using a Philips head screwdriver to remove each of the (3) screws.
5. Install (4) wood screws to cabinet bottom. These screws will be used to secure the hood to the cabinet.
6. Lift hood onto screws located on cabinet bottom and lock into place. Make sure all (4) key-holes cover the screws. Tighten each screw to secure hood to cabinet.
7. Install electrical.
8. Install duct work and seal with aluminum duct tape.
9. Power up hood and check for leaks around duct tape and test all functions.
10. Reinstall bottom panel and re-connect lighting harness.
11. Slide residue cups into their openings on the bottom of the hood. Install safety grilles over each blower opening and secure with the two safety grille screws.

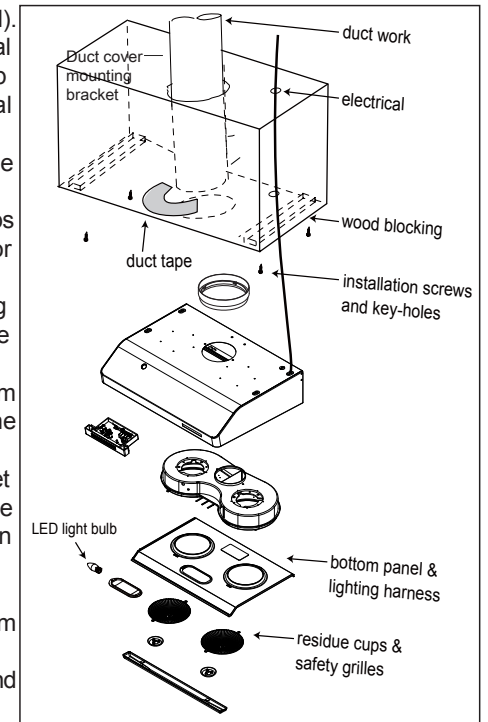

Fig 1

V. Operating Instructions



1. “ Power / Delay -Off ” Button

- (1) Turn On or Turn Off the hood.
- (2) First time turn on the hood, hood will at Low fan speed and light on.
- (3) Hood will remember the last speed and light level it was turned off at.
- (4) With the fans on press Power/Delay-Off button to turn off the entire hood (fan and light).
- (5) With the fans on press and hold Power/Delay-Off button for three seconds to activate Delay Off function. The fan will change to Low speed and the 5 minutes delay off timer will start.
The fan speed and light level can be adjusted during 5 minutes Delay Off.
The LED indicator under this button will illuminate and slowly blink in accordance with the time remaining until the fan and light automatically turn off.
- (6) Pressing Power/Delay-Off button while Delay-Off function is enabled will turn the hood off and cancel the Delay-Off function.

2. “ Speed Down ” Button

- (1) Press this button to decrease the fan speed.

3. “ Speed Up ” Button

- (1) Press this button to increase fan speed.

4. “ Auto Clean ” Button

- (1) Pressing Auto Clean button to activate the auto clean function. The LED indicator under Auto Clean button will illuminate. Pressing Auto Clean button or Power button while auto clean function is enabled will cancel the auto clean function.
- (2) Auto Clean button is invalid while Delay Off function.
- (3) Auto Clean button is invalid while fans on.
- (4) After 30 hours of fans usage, the indicator of Auto Clean will begin to slowly blink indicating it is time to clean the hood. Press and hold Auto Clean button for three seconds to cancel reminder.

5. “ Light ” Button

Pressing Light button to turn on or turn off the light, it will not impact the fan. When light on, the LED indicators under Light button will illuminate.

七. 注意事項及警告標示

一. 功能說明：

本機利用市售廚房專用的除油清潔劑與水混合後，注入機器內水箱用，利用摩打高速運轉時之離心力及衝擊備力，達到清洗內部的功能，可保持排油煙機內部清潔，延長排油煙機使用壽命。

二. 操作說明：

1. 使用專用水壺，先加入清水到指定分量，再倒入清潔劑混合。
2. 將水壺從機器之注入口倒入稀釋清潔劑，排油煙機內有隱藏式水箱，容量與水杯相同。
3. 當溢水孔溢出稀釋清潔劑時即表示水位已滿，應停止再注清潔劑入水箱中。
4. 按“自動清洗”掣即啟動摩打，機器自動噴出清潔劑，清洗機器內部。
5. 當油杯水位到警戒線時，應取下倒去油污，以防外溢。

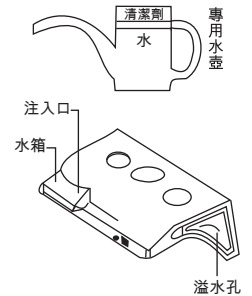

三. 注意事項及警告標示：

1. 請使用市售之廚房專用清潔劑。
2. 請按照隨機附有的水壺上指示添加水及清潔劑。
3. 建議消費者最多每日清洗排油煙機一次即可，亦可按需要減少清洗次數以節省清潔劑。
4. 注入清潔劑時，請用隨機附有的水壺，小心到進水箱勿使清潔劑溢出機外。
5. 清洗時請注意，勿使油污超過油杯警戒線，以防油污溢出。
6. 請謹防異物流入水箱中，以防止噴水孔堵住。
7. 每一水壺約可使用2~3次，可於用畢後，再重新倒進清潔稀釋液以防過滿。如內水箱過滿，水會自動排出機外直落盛油杯。
8. 每次煮食前先開啟抽油煙機，在開始煮食，可防止高溫損壞排油煙機。
9. 假若電源線損壞時，必須經由製造廠商或服務站或是類似專業的人員更換，避免造成危險。

八. 排除故障

異常狀況	原因	處理方式
馬達不轉	1. 無電源輸入 (電源線燒毀) 或保險絲燒毀	1. 更換PC板
	2. 馬達溫控跳脫無法回復	2. 更換馬達
	3. 馬達銅線燒毀	3. 更換馬達
	4. 電容器燒毀	4. 更換電容器
	5. 無電源輸入 (電源線燒毀) 或保險絲燒毀	5. 三用電表測 (更換電源線)
馬達轉速變慢	1. 電容器變形或電量不足	1. 更換電容器
	2. 馬達燒毀	2. 更換馬達
風葉有反轉現象	1. 馬達銅線短路	1. 更換馬達
	2. 出風口逆風現象 (倒灌風)	2. 出風口或排風管阻塞清理
馬達無分段速度	1. 電容器燒毀	1. 更換電容器
	2. 線路脫落	2. 重整電線
馬達時轉時不轉	1. 溫控在感應到異常高溫時，馬達會停止轉動，當溫度降到一般煮食時，會恢復正常運作	1. 建議煮食方法稍改：若煮食時長時間用大火，建議改用中小火或暫停煮食
		2. 更換馬達
	2. 馬達溫控跳脫會時有時無	3. 更改馬達結線，不使用溫控
Delay off 延遲失效	1. 主控PC板失效	1. 更換主控PC板
	2. 開關PC板失效	2. 更換開關PC板
漏電	1. 馬達入水造成	1. 更換馬達
LED燈失效	1. LED燈控制線斷路	1. 更換LED燈控制線
	2. 主控PC板燈線斷路	2. 更換主控PC板
	3. LED燈故障	3. 更換LED燈
顯示器失效	1. 主控PC板失效	1. 更換主控PC板
	2. 開關PC板失效	2. 更換開關PC板
清洗失效	1. 開關PC板失效	1. 檢查PC板或更換PC板
	2. 噴水孔堵塞	2. 檢查噴水孔
	3. 噴水馬達失效	3. 更換噴水馬達

VI. Surface Maintenance

A. Surface Maintenance

1. Please clean the range hood surface regularly with warm soapy water and wipe with a cotton cloth to prevent grease from accumulating.
2. Please do not use harsh cleansers or coarse material to clean the surface because that will damage the surface.
3. A non-invasive stainless steel polish is recommended to polish the surface after cleaning.
4. Please use soft cloth for polishing because it will make your range hood surface shinier.
5. Please do not use cleaning solutions that have bleach as an ingredient.

B. Surface Cleaning and Maintenance

1. Always disconnect from power supply before cleaning.
2. Clean both exterior and interior of the hood for long lasting. Do not use abrasive cleanser.
3. Fan's protection grille can be detached for cleaning by removing the screws with a screwdriver. It must be reinstalled before using the range hood again.
4. Oil dish on the grille can also be detached for cleaning by turning the dish counter-clockwise.
5. The oil cup in the center of the hood for holding grease can be detached and cleaned regularly.
6. Make a habit of turning on the range hood first before turning on the stove to avoid high temperature in the kitchen.

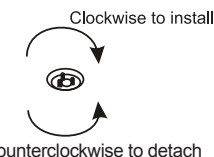
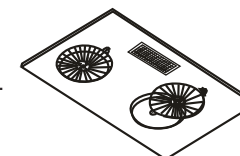

VII. Remarks

A. Features:

The range hood shall be cleaned by using the special range hood cleaner available in the market. After the cleaner is mixed with water, the cleaner mixture shall be poured into the cleaner storage unit and stored in the range hood for cleaning later. The cleaning process works on the centrifugal force and cleaning power generated by revolving the motors at high speed, It keeps the inside of the range hood clean and prolongs the life of the range hood.

B. Operating Instructions:

- Mix the cleaner and water by pouring water and the cleaner to the marked level of the provided jar.
- Pour the cleaner mixture in the jar into the hidden cleaner storage unit of the range hood through the water hole as shown in the picture.
The volume of the cleaner storage unit is identical to the volume of the jar.
- If cleaner mixture comes out from the excess water hole down into the oil retainer, it means the cleaner storage unit is full and no more cleaner mixture shall be poured into the water tank.
- Press the "Auto Clean" Button to start the motors and the cleaner will be discharged automatically and cleans the inside of the range hood.
- The oil retainer shall be taken out to remove the dirty oil once the dirty oil reaches the marked line to prevent spillage.

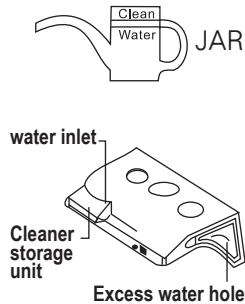

C. Precautions:

- Only special range hood cleaner available in the market shall be used. (Recommended agean: Kao Magiclean Household / Kitchen cleaner)
- Follow the water and cleaner mixture ratio marked on the supplied jar.
- Consumers are advised to clean the range hood once a day.
It may be cleaned less frequently according to individual needs.
- When filling the range hood with the cleaner mixture, use only the special jar provided with the range hood and take precautions not to overfill the cleaner storage unit.
- Check the oil retainer during the cleaning process to prevent oil spillage. Do not allow dirty oil to exceed the marked level.
- Do not put any other substances into the cleaner compartment unit as this will cause blockage of its injection hole.
- A supplied jar can be used for 2 to 3 times. The cleaner storage unit may be refilled by diluted cleaner mixture every time after use. To prevent overfilling, excess cleaner mixture will be discharged into the oil retainer automatically.
- Always turn the range hood on first before turning the cooktop on as high heat may damage the range hood.
- If the supply cord is damaged, it must be replaced by the manufacturer or its service agent or a similar qualified person in order to avoid a hazard.

VIII. Troubleshooting

Problem	Possible Cause	Solution
Motor stops running	1. No power (burned wire or fuse)	1. Replace the PC board
	2. Motor temperature regulator is off and can't be recovered	2. Replace motor
	3. Motor copper wire is burned	3. Replace motor
	4. Capacitor defected	4. Replace capacitor
	5. No power (burned wire) or burned fuse	5. Check power meter (replace power cord)
Motor speed slows down automatically	1. Distorted capacitor or low power	1. Replace capacitor
	2. Motor defected	2. Replace motor
Inverted fan blades	1. Short circuit on the motor	1. Replace motor
	2. Air comes out of the air outlet instead of sucks up	2. Air outlet or exhaust pipe is blocked and needs cleaning
Motor doesn't regulate speed	1. Capacitor defected	1. Replace capacitor
	2. Electrical wiring is off	2. Fix the electrical wires
Motor runs on and off	1. Motor stops running when it reaches unusual high temperature, and starts again when it cools down to normal cooking temperature. This is cause by temperature running too high during cooking.	1. Recommend changing your cooking routine slightly
	2. Motor temperature regulator comes on and off	2. Replace motor
Delay-off function fails	1. Main control PC board failed	1. Replace main control PC board
	2. PC board switch failed	2. Replace PC board switch
Power leakage	1. Water got in the motor	1. Replace motor
LED light not working	1. Short circuit on LED light control power cord	1. Raplace LED light control power cord
	2. Short circuit on the light power cord in the main control PC board	2. Replace main control PC board
	3. LED light failed	3. Replace LED light
Display unit failed	1. Main control PC board failed	1. Replace main control PC board
	2. PC board switch failed	2. Replace PC board switch
Clean failed	1. PC board failed	1. Replace PC board
	2. Nozzle is clogged	2. Check nozzle
	3. Water pump failed	3. Change water pump