

# TW4000 & TW9000 OWNER'S MANUAL

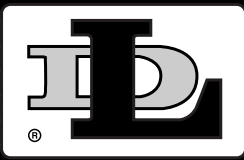

## StrongArm® 12 Volt DC ELECTRIC TRAILER WINCHES



**⚠ WARNING:** READ INSTRUCTIONS CAREFULLY BEFORE ATTEMPTING TO INSTALL, OPERATE OR SERVICE THE STRONGARM ELECTRIC WINCH. FAILURE TO COMPLY WITH INSTRUCTIONS COULD RESULT IN SERIOUS OR FATAL INJURY. RETAIN INSTRUCTIONS FOR FUTURE REFERENCE.

E  
N  
G  
L  
I  
S  
H

### WINCH RATINGS

**ELECTRIC WINCH RATING**

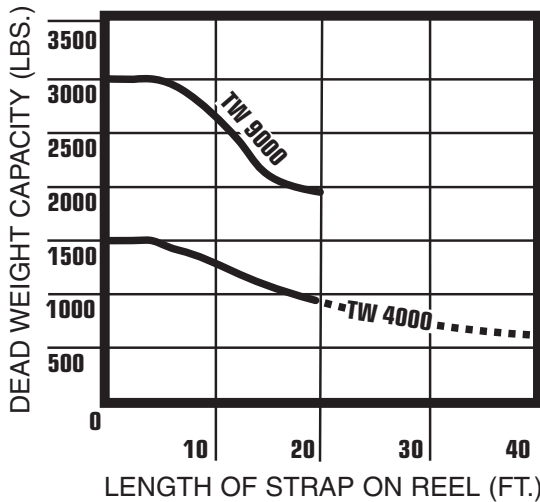

StrongArm TW electric trailer winches are manufactured for loading and unloading of boats, personal watercraft, vehicles, etc. The TW4000 winch features power-in, free wheel out and 20' of 2" wide strap. The TW9000 features power-in, power-out, free wheel and 20' of 2" wide strap.

Note that as strap builds up on the reel, the pulling capacity of the winch decreases (see graph at left). For intermittent use only. Ratings at left are based on 6' pull. For longer pulls adequate motor cooling periods must be allowed.

TW4000-MAXIMUM CONTINUOUS RUN TIME  
3 MINUTES

TW9000-MAXIMUM CONTINUOUS RUN TIME  
4 MINUTES

**⚠ CAUTION:** CONTINUOUS RUNNING IN EXCESS OF 3 MINUTES (TW4000) AND 4 MINUTES (TW9000) WILL DAMAGE WINCH MOTOR.

**GUIDE TO ROLLING LOAD CAPACITY\*\***  
Maximum weight in pounds and kilograms rolling load.

MODEL	PERCENT INCLINE						LOAD CAPACITY
	5% (3°)	10% (6°)	20% (11°)	30% (17°)	50% (26°)	70% (35°)	
TW4000	10,000 lbs. 4,536 kg	7,500 lbs. 3,402 kg	5,100 lbs. 2,313 kg	3,900 lbs. 1,769 kg	2,700 lbs. 1,225 kg	2,200 lbs. 998 kg	1500 lbs. 681 kg
TW9000	20,000 lbs. 9,072 kg	15,000 lbs. 6,804 kg	10,200 lbs. 4,627 kg	7,700 lbs. 3,493 kg	5,500 lbs. 2,495 kg	4,500 lbs. 2,041 kg	3,000 lbs. 1,362 kg

**APPROXIMATE LOAD SPEED (FT./MIN.)**

	NO LOAD		FULL LOAD	
	Full Reel	Empty Reel	Full Reel	Empty Reel
TW4000	22	11	8.2	4.4
TW9000	15	9	6.3	4.3

(\*\*) All capacities shown are with 2' of strap on the reel and 10% rolling friction factor. For full reel of line adjust capacities according to graph above. Note 5% incline is one-half foot rise in ten feet.

TW series electric winches are built for trailer loading and other horizontal pulling applications. They are not to be used for lifting, supporting or transporting people or loads over areas where people could be present or for any vertical lifting or lowering applications.

# IMPORTANT SAFETY INFORMATION

- ⚠ **WARNING: FAILURE TO READ AND FOLLOW INSTRUCTIONS BELOW COULD RESULT IN SERIOUS OR FATAL INJURY.**
- ⚠ **WARNING:** This winch is built for trailer loading and other horizontal pulling applications. **NOT TO BE USED FOR LIFTING, SUPPORTING OR TRANSPORTING PEOPLE OR LOADS OVER AREAS WHERE PEOPLE COULD BE PRESENT OR FOR ANY VERTICAL LIFTING OR LOWERING APPLICATIONS.**
- ⚠ This electric winch should be respected as power equipment. High forces are created when using a winch, creating potential safety hazards. Never allow children or anyone who is not familiar with the operation of the winch to use it.
- ⚠ Never exceed rated winch load. Dangerously high forces can be created if the load being moved is too large or is allowed to get in a bind, etc. Pay attention to the sound of the winch and stop pulling immediately if the winch begins to stall. Note that installing longer than normal line results in increased load on the winch.
- ⚠ Winch is equipped with high-quality strap capable of handling the rated winch load. Never exceed the rated capacity. Do not use vehicle pulling power to increase the pulling capacity of your winch.
- ⚠ Keep the winching area free of all unnecessary personnel. Never stand between load and winch or directly in line with load and winch.
- ⚠ This winch operates from a low voltage 12 volt D.C. power source (e.g., a car or truck battery). DO NOT connect winch to 120V A.C. power.
- ⚠ When winching operation has been completed, do not depend on the winch to support the load. Always secure the load properly. Use tie down straps or chains.
- ⚠ The auxiliary handle is for emergency use only. Never use the auxiliary handle as an assist to the motor when the motor is running. Always remove the auxiliary handle when it is not in use. Do not operate the winch motor or allow the winch to free wheel with the handle installed.
- ⚠ Keep hands and fingers clear of the drum and line area of the winch when operating. Do not attempt to guide the line by hand as it rewinds on the drum.
- ⚠ The winch must be securely attached to a structural member or frame that is capable of sustaining loads in excess of the winch capacity. When attaching the winch to a vehicle, make sure the mounting pad area is rigidly supported by the vehicle frame. Always block the wheels to prevent vehicle from rolling when pulling a load with the winch.
- ⚠ When releasing a load with the clutch, maintain control of the speed. Excess speed could result in winch damage and serious personal injury.
- ⚠ Keep the pull of the strap onto the reel as straight as possible to avoid strap damage.
- ⚠ Inspect strap and hook on each use and replace at the first sign of wear or abnormal appearance.

## MOUNTING INSTRUCTIONS

1. Be sure that the mounting surface is of sufficient strength to support a load well in excess of the rated winch capacity.
2. Fasten the winch to the trailer winch stand (or other mounting surface) with three 1/2" bolts, nuts, washers and lock washers. Be sure that the winch is positioned so that the strap winds onto the reel as straight as possible.
3. On boat trailer installations the winch stand should be adjusted so that the loading ring on the bow of the boat is at the same height or slightly higher than the winch drum when the boat is fully loaded on the trailer.

Be sure that the trailer-bow stop is located far enough back of the winch drum so that the strap hook is not drawn into the drum when the boat is fully loaded on the trailer.

4. Your winch is equipped with keyhole slots in the base for use with quick mounting shoulder studs, if desirable. (See FIG. 1) If you wish to use quick mount studs, (DL Accessory No. 6365) they should be mounted securely into the winch stand. After positioning the winch on the studs, a 3/8" bolt should be placed in one of the other holes available to keep the winch securely in position.

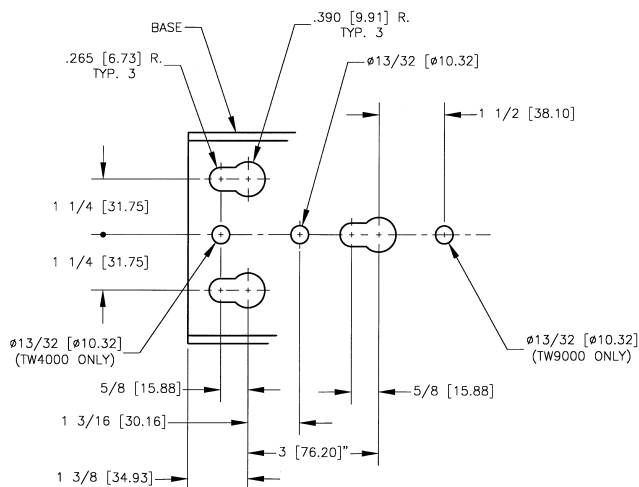

FIG. 1

## WIRING HARNESS INSTALLATION

The wiring harness is designed to remain in the towing vehicle when not in use. This prevents tampering, accident or misuse since the harness is needed to operate the winch electrically.

These installation instructions provide ready access for use, yet allow the complete harness to be quickly removed if desired.

1. Feed positive lead (long) wire only through any convenient access hole inside the car trunk. It may be necessary to remove a knockout plug or rubber grommet from the trunk floor. It may also be necessary to remove the circuit breaker assembly from the positive wire in order to feed the wire under the car.
2. Pull the positive lead wire along the underside of the car into the engine compartment and up to the battery. Fasten the wire to the car undercarriage with existing wiring clamps and brackets, making sure wire is not located near the exhaust system, or any hot or moving parts. Wire should be fastened securely and without slack. Excess wire should remain in the trunk.
3. Fasten the circuit breaker to the positive (+) battery terminal (if nut and bolt type) or to the battery side of the starter solenoid.
4. Attach negative wire to vehicle frame using a 1/4" bolt and locknut. Make sure you have a clean, tight connection.

NOTE: If winch is to be mounted in front of vehicle, cut harness to the length needed making sure, if spliced, the splice is tight and well insulated. Attach ground as described in 4 above.

## LOADING AND UNLOADING UNDER POWER

### MODEL TW4000

1. Attach the plug end of the power supply (wiring harness) into the connector located at the back of the winch. This pushes and snaps into place easily and will only fit in one direction. With the clutch knob in the "Engaged" position, activation of the toggle switch on the side of the winch will power a load in. The switch is spring loaded and will stop the winch and lock the load in position when toggle is released. Leave your

car engine running on fast idle as a precaution in case the battery is not in top condition.

2. Always disconnect the power when winching operation is complete. To disconnect power supply, simply pull the plug end of power supply from the winch.

### MODEL TW9000

1. Attach the plug end of the power supply (wiring harness) into the connector located at the back of the winch. This pushes and snaps into place easily and will only fit in one direction. With the clutch lever in the "Engaged" position, you may power the winch in either the load or unload direction. The switch is spring loaded and will stop the winch and lock the load in position when switch lever is released. Leave your car engine running on fast idle as a precaution in case the battery is not in top condition.
2. Always disconnect the power when the winching operation is complete. To disconnect power supply simply pull the plug end of power supply from the winch.

NOTE: It is normal for smoke to be produced during the initial power down use.

### TW4000 AND TW9000

**⚠ WARNING: EVEN THOUGH THE WINCH IS EQUIPPED WITH CIRCUIT BREAKER OVERLOAD PROTECTION, PARTICULAR CARE SHOULD BE TAKEN NOT TO CREATE AN OVERLOAD. PAY ATTENTION TO THE SOUND OF THE WINCH AND THE LOAD BEING PULLED. MAKE CERTAIN THAT THE STRAP TENSION DOES NOT RISE SUDDENLY BECAUSE OF A BIND IN THE LOAD.**

**⚠ CAUTION: The electric motor is designed for intermittent service only. Extended use without cooling off periods will cause overheating resulting in motor damage. Maximum recommended continuous run time is three minutes (TW4000) and four minutes (TW9000).**

**⚠ CAUTION: These winches are built for trailering boats, PWC's, vehicles, etc. Secure the load onto the trailer with appropriate bow and transom tie down straps or chains. With the load fully secured on the trailer, it is advisable to relieve the tension on the winch strap to avoid damage to the winch and trailer due to high shock loads encountered when traveling.**

## CLUTCH OPERATION

1. The knob (TW4000) or clutch lever (TW9000) provides a means for releasing a load without power while maintaining control of the speed and provides for freewheeling so that strap can be removed from the winch by hand. The clutch lever on the TW9000 is spring loaded so that it returns to the engaged position when released. The lever will, however, remain in the freewheeling position if rotated completely forward to freewheel.

- In order to release a load without power, rotate the knob or clutch lever slowly and carefully forward toward "Freewheel." When the load begins to move, it can be controlled by the knob or clutch lever. Careful, slow movement of the knob or lever will provide smooth control of the load.

**⚠ WARNING: ALWAYS MAINTAIN CONTROL OF THE LOAD. ALLOWING EXCESS SPEED COULD RESULT IN WINCH DAMAGE AND SEVERE PERSONAL INJURY.**

- Remember that the gear train and brake mechanism are completely disengaged in the "Free Wheel" position and in order to power the winch or hold a load in position, the knob or lever must be returned to the "Engaged" position.

NOTE: On the TW9000 it is not necessary to turn the clutch lever completely to the "Engaged" position manually. The spring tension built into the winch provides adequate force on the clutch lever.

**⚠ CAUTION: Never force knob or clutch lever in either direction.**

## AUXILIARY HANDLE

An emergency crank handle is provided for the model TW9000 for use in the event of a power failure. The model TW4000 requires the use of a ratchet wrench and 5/8" deep well socket or a standard 5/8" socket with an extension.

- Disconnect the electrical power from the winch and remove the plastic plug from the side of the winch housing.

**⚠ WARNING: NEVER OPERATE THE WINCH ELECTRICALLY WITH THE EMERGENCY HANDLE OR RATCHET WRENCH IN POSITION.**

### TW4000

- Insert the 5/8" socket and ratchet handle so that it completely engages with the drive shaft. **Turn the drive shaft in the counterclockwise direction only.** (See Fig. 2)

**⚠ WARNING: KEEP THE CLUTCH KNOB IN THE "ENGAGED" POSITION WHILE CRANKING WINCH. DO NOT PUT CLUTCH IN "FREE WHEEL."**

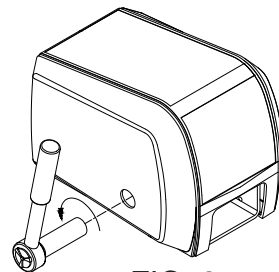

FIG. 2

Socket & Ratchet Handle Illustration (TW4000)

### TW9000

- Insert the emergency handle so it completely engages with the drive shaft. Pull in strap by turning the handle in the clockwise direction (See Fig. 2A). To make cranking easier, the clutch handle can be placed in the "free wheel" position while holding onto the emergency crank handle.

**⚠ WARNING: IF THE CLUTCH IS PLACED IN FREE WHEEL FOR HAND CRANKING, BE SURE TO MAINTAIN A FIRM GRIP ON THE HANDLE AT ALL TIMES.**

Because the TW9000 emergency crank handle

attaches to the clutch side of the winch, it is equipped with a spring-operated clip which will be depressed by the clutch handle in the free wheel position when cranking in a clockwise direction to retrieve strap. This clip is a safety feature and will re-engage the clutch mechanism in the event the operator loses control of the handle with a load on the winch.

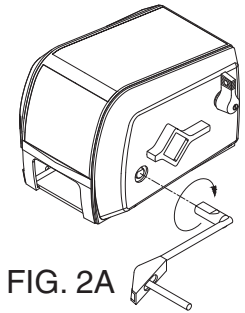

FIG. 2A

Emergency Handle Illustration (TW9000)

**⚠ WARNING: EVEN WITH THIS SAFETY FEATURE, THE HANDLE WILL SPIN VIOLENTLY ONE OR TWO TURNS BEFORE RE-ENGAGING THE CLUTCH TO STOP THE WINCH. DO NOT LOSE CONTROL.**

- Always remove the handle from the winch after use and replace the plastic plug.

## WINCH MAINTENANCE

For long life and trouble-free operation your winch should periodically be inspected for any required maintenance. This should be done at least once annually and more frequently in adverse conditions such as salt water areas or areas of extreme dust and dirt.

**⚠ WARNING: BEFORE PERFORMING ANY MAINTENANCE BE SURE THERE IS NO LOAD ON THE WINCH AND THAT THE POWER HAS BEEN DISCONNECTED.**

- Carefully inspect the winch strap and replace at the first sign of damage. **Go to Dutton-Lainson website: <http://www.dutton-lainson.com/ts.php> for trouble shooting manual, select winch model number and click on symptom "Strap Damage" and "Strap Breaks" for complete diagnoses and corrective action.** In order to replace the winch strap, it is necessary to remove the winch cover. On the TW4000, remove the slotted nut in the end of the knob with a screwdriver and unscrew the knob from clutch stud. Remove the nut holding the toggle switch into the cover and push the switch inside the winch. Remove the cover screws and lift the cover from the winch while gently stretching it open to clear the clutch stud. On the TW9000, remove the clutch handle by removing the two clutch handle screws and then remove the cover screws. Lift the cover from the winch while gently stretching it open to clear the clutch stud.

Rotate the winch reel to gain access to the strap bolt. Remove the old strap and replace it with a new strap of the same size. If the strap bolt is bent, replace it with a bolt of the same size and length. Note that nut on the strap bolt must be on gear side of winch reel and locknut must be used. Do not substitute free running nut. Slide bolt to bottom of slot and tighten nut until snug. Do not over tighten, strap will hold bolt in bottom of slot.

NOTE: STRAP IS WOUND OVER THE TOP OF THE DRUM ON MODEL TW4000 AND UNDER THE DRUM ON MODEL TW9000.

- With the cover removed as described above, inspect the entire gear train and all drive shafts for any signifi-

cant wear or loose bearing fits. Also, check all nuts, bolts, retaining rings, etc., to be sure that they are tight and secure. Grease all of the gears on the inside of the winch base and apply a drop of oil on all of the bearings in the clutch mechanism and place a drop of oil on the roller clutch. Do not over lubricate these areas and do not use grease in the roller clutch. The clutch mechanism and the brake pads and brake disc on the TW9000 must be kept clean and oil free.

**ADDITIONAL MAINTENANCE TW9000**

3. Check the operation of the roller clutch in the brake disc assembly (AF). Carefully rotate the brake disc and observe the motor shaft. When the disc is turned clockwise the motor shaft should turn with it. When the disc is turned counterclockwise the motor shaft should not turn.
4. If the clutch has been slipping and requires adjustment the following procedures should be used. The clutch is adjustable in ten degree increments. With a screwdriver and pliers, remove the end of the clutch spring from the hole in the winch base. The spring tension is quite high so be careful to maintain a firm grip on the spring. The O-ring should be rotated so that the cut out portions align with the lugs on the spring keeper. (See FIG. 3)

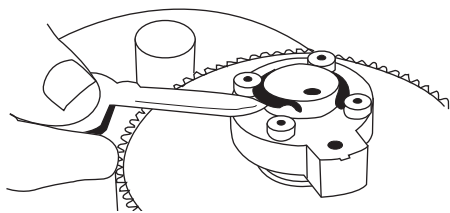

O-Ring Illustration (TW9000)

FIG. 3

The ring can then be expanded with a pencil or similar object and the spring keeper can be lifted free from the clutch nut. Rotate the keeper clockwise 10 degrees and install on the next serration in the clutch nut. Reinstall O-ring and rotate slightly so that the cut outs are not in line with the lugs on the spring keeper and reinstall the clutch spring into the hole in the base. Adjustment of the clutch more than 10 degrees to 20 degrees should normally not be necessary. With only spring pressure (do not forcibly tighten the clutch mechanism) the spring lug on the spring keeper should come to rest at approximately the 2:30 o'clock position. (See FIG. 4)

**Go to Dutton-Lainson website:**

**<http://www.dutton-lainson.com/ts.php> for trouble shooting manual, select winch model number and click on symptom "Motor runs but winch fails to pull strap" for complete diagnoses and corrective action.**

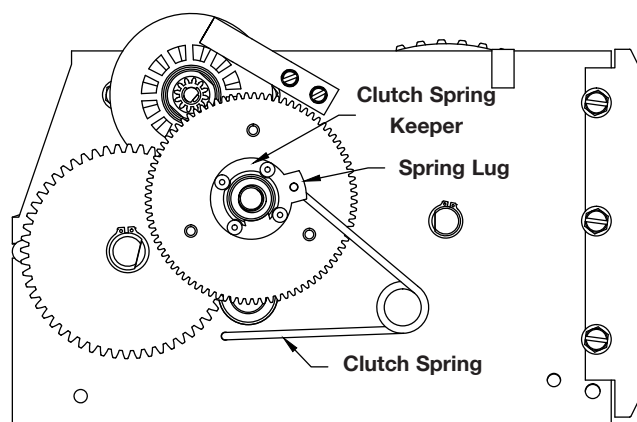
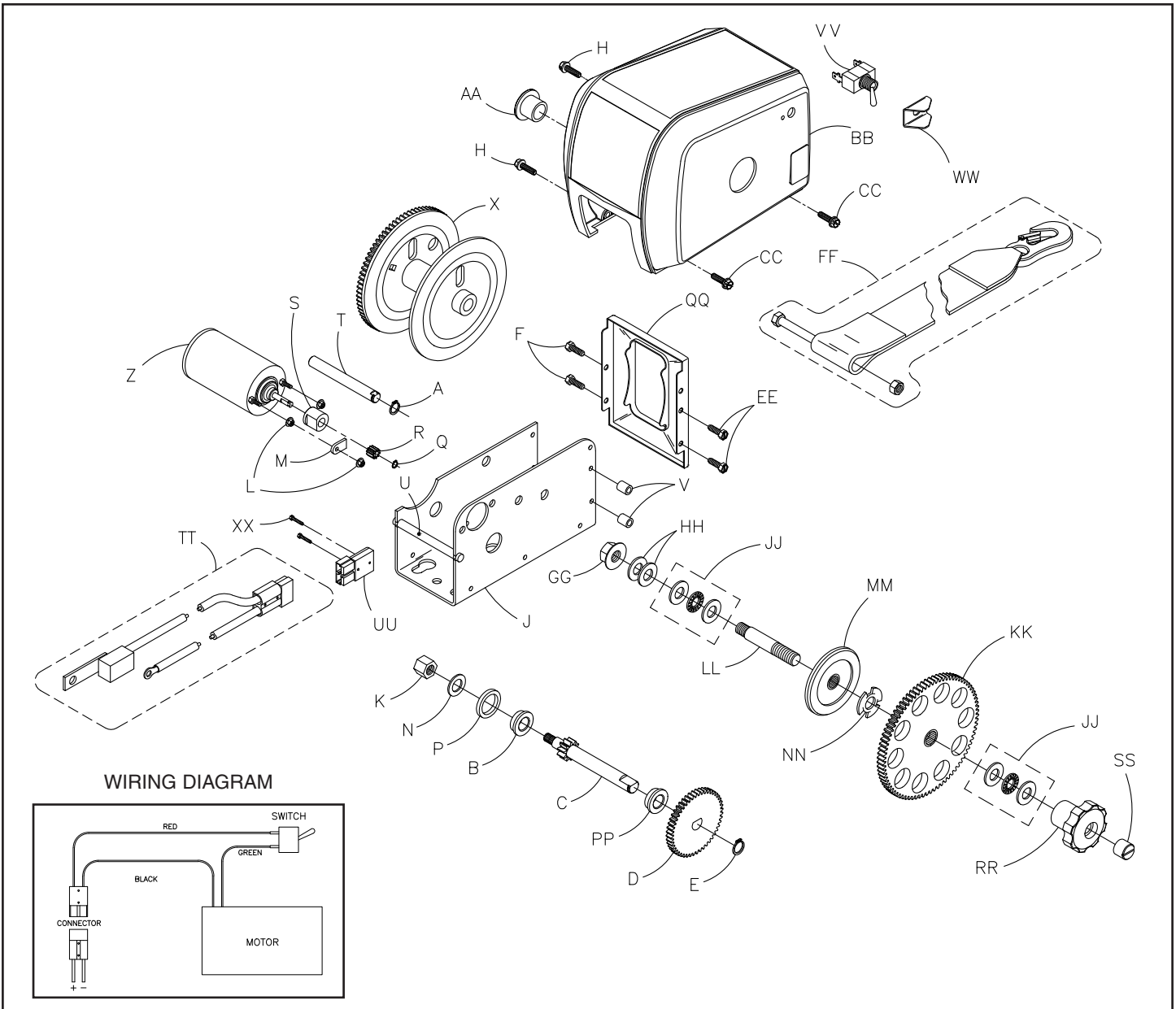

FIG. 4

Clutch Spring Illustration (TW9000)

If you are having any problems with this electric winch, go to Dutton-Lainson website: <http://www.dutton-lainson.com/ts.php> to view trouble shooting manual. This manual will help diagnose most problems with this winch.



## TW4000 PARTS LIST

Ref. Part	Number	Ref. Part	Number
A Retaining Ring	204468	AA Cover Plug	206040
B Bushing	204006	BB Cover	406154
C Drive Shaft Ass'y	304967	CC Mounting Screw (2)	205190
D 56T Gear	204703	EE Screw (2)	205238
E Retaining Ring	205191	FF Strap 2" x 20"	5242607
F Screw (2)	205337	GG Locknut 7/16-20	205192
H Screw (2)	205338	HH Washer (2)	204360
J Base	406155	JJ Thrust Bearing Replacement Kit	5703194
K Hex Nut	406002	KK 120 Tooth Gear Ass'y	306102
L Locknut 10-32 (3)	205193	LL Clutch Stud	404826
M Stop	404829	MM Clutch Gear Ass'y	306100
N Washer	205109	NN Finger Spring Washer	205200
P Washer	203813	PP Bushing	204012
Q 'E'-Ring	205135	QQ Front Plate	406136
R Motor Pinion	206228	RR Knob	206243
S Roller Clutch Ass'y	304698	SS Slotted Nut	404614
T Reel Shaft	404559	TT Wiring Harness	306225
U Base Spacer	404557	UU Connector	206055
V Spacer (2)	404562	VV Toggle Switch	206249
X Reel Ass'y	304858	WW Toggle Switch Guard	404831
Z Motor	306224	XX Screw (2)	204959
		YY Top Decal (not shown)	206675

To order replacement parts contact:

**Dutton-Lainson Company**

www.dlco.com  
 Tel: 800-569-6577  
 Fax: 402-460-4612  
 e-mail: DLsales@dutton-lainson.com

**In Europe Contact:**

**Bainbridge International Ltd.**

8 Flanders Park  
 Hedge End  
 Southampton  
 Hampshire SO30 2FZ  
 UK  
 Tel: +44 (0) 1489-776050  
 Fax: +44 (0) 1489-776055  
 www.bainbridgmarine.co.uk

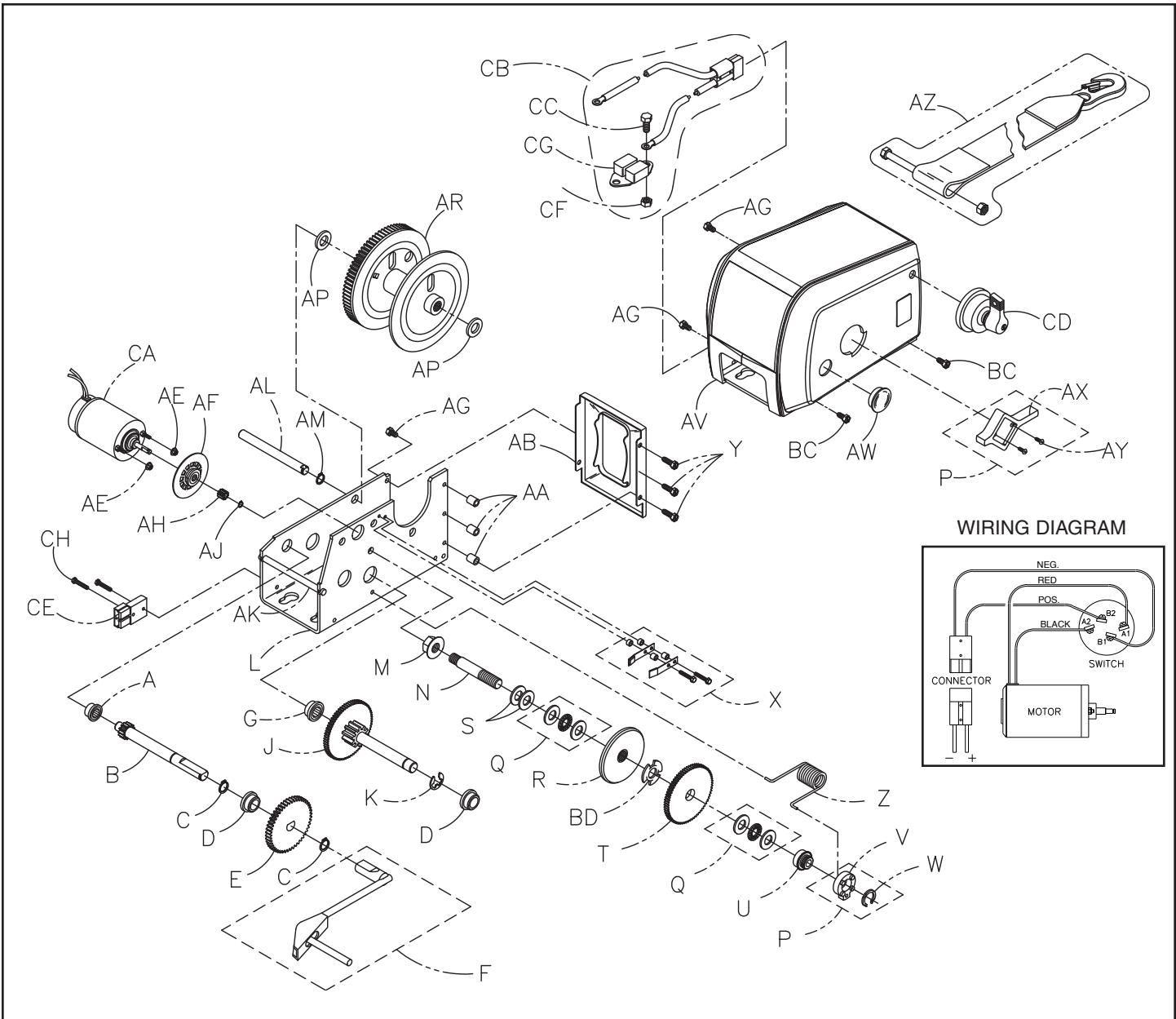

## TW9000 PARTS LIST

Ref. Part	Number	Ref. Part	Number	MOTOR PARTS				
A	Bearing Housing Assy.	304314	X	Brake Spring Replacement Kit	5703160	CA	Motor Assy	304742
B	Primary Drive Shaft Assy.	304304	Y	Screw, 1/4-20x7/8" (3)	205242	CB	Connector Ass'y	5241518
C	Retaining Ring (2)	205191	Z	Clutch Spring	204711	CC	Screw - 1/4x20x3/8	205018
D	Bushing (2)	204012	AA	Spacer (3)	404513	CD	Switch	206007
E	56T Gear	204703	AB	Front Plate	404495	CE	Connector	206055
F	Aux. Handle Assy.	5703079	AE	Nut, 10-32 Locknut (2)	205193	CF	Nut - 1/4-20	206225
G	Drive Shaft Bushing	304313	AF	Brake Disc Assy.	304422	CG	Circuit Breaker Assy	304025
J	Interm. Drive Shaft Assy.	304814	AG	Screw, 1/4-20x1/2" (4)	205189	CH	Screw, 6-32x7/8" (2)	204959
K	"E" Ring	205116	AH	12T Pinion Gear	404522	To order replacement parts contact:		
L	Base	404932	AJ	"E" Ring	205135	<b>Dutton-Lainson Company</b>		
M	Nut, 7/16-20 Locknut	205192	AK	Base Spacer	404510	www.dlco.com		
N	Clutch Stud	404517	AL	Reel Shaft	404514	Tel: 800-569-6577		
P	Clutch Handle Replacement Kit	5703178	AM	Retaining Ring	204468	Fax: 402-460-4612		
Q	Thrust Bearing Replacement Kit	5703194	AP	Washer (2)	205109	e-mail: DLsales@dutton-lainson.com		
R	Clutch Gear Assy.	306100	AR	Reel Assy.	304815	<b>In Europe Contact:</b>		
S	Washer (2)	204360-PL	AV	Cover	406134	<b>Bainbridge International Ltd.</b>		
T	84T Gear Assy.	306101	AW	Cover Plug	204713	8 Flanders Park		
U	Clutch Handle Nut	404518	AX	Clutch Handle	204712	Hedge End		
V	Clutch Spring Keeper	204721	AY	Screw - #4x1/2	205196	Southampton		
W	"O"-Ring	204770	AZ	Strap (2" x 20')	5242516	Hampshire SO30 2FZ		
			BC	Screw (2)	205190	UK		
			BD	Finger Spring Washer	205200	Tel: +44 (0) 1489-776050		

# ELECTRIC WINCH SERVICE CENTERS

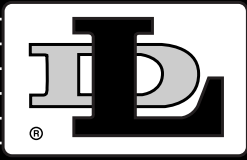

## FLORIDA

Hagood Brothers Marine  
1121 West Church St.  
Orlando, FL 32805  
Tel: 407-843-4220

## MISSOURI

Stewart Enterprises  
Route 2, Box 33C  
Cameron, MO 64429  
Tel: 816-632-6578

## NEBRASKA

Dutton-Lainson Company  
1601 West 2nd  
Hastings, NE 68902  
Tel: 402-462-4141

## NEW YORK

American Marine  
2161 Jericho Turnpike  
Commack, NY 11724  
Tel: 631-543-6433

These authorized centers will be able to supply parts and technical service on all StrongArm® Electric Winches  
For warranty claims follow instruction given in "Limited One Year Warranty."

**DECLARATION OF CONFORMITY** - Dutton-Lainson Company, Hastings, NE 68902-0729 U.S.A. manufactures and declares that the winch identified above fulfills all relevant provisions of the Directive 2006/42/EC. The technical file may be obtained from the persons listed below.

Hastings, NE USA  
May 1, 2017

A handwritten signature in black ink, appearing to read 'Jeff Dobbin'.

Director of Engineering  
Dutton-Lainson Company

Jack Singleton  
Bainbridge International Limited  
8 Flanders Park, Hedge End, Southampton,  
Hampshire, SO30 2FZ UK

## NOTES

WINCH MODEL NUMBER: \_\_\_\_\_ WINCH DATE CODE: \_\_\_\_\_

DATE PURCHASED: \_\_\_\_\_ (LOCATED INSIDE FRAME AT REAR)

---

---

---

---

---

---

---

---