



# WARN Industrial Winch

Model	Part Number	Motor Type
<b>Series 15-A-59 Hydraulic Winch Manual Clutch</b>	<b>65931</b>	Hydraulic 6.1 ci (100 cc)

The Series 15 hydraulic winch features a 2 stage planetary gear train with a total reduction of 36:1. This winch uses a heavy duty automatic disc brake and a locking clutch lever. The 4" (102mm) steel drum provides excellent durability for the wire rope. Designed to meet SAE J706 and CE standards.



## Accessories

Description:	Part Number
Wire Rope Tension Plate 10"	31149
Fairlead Black 10"	24336
Fairlead Chrome 10"	30859
Remote Clutch Mechanical	38316
Remote Clutch Air	71370
Wire Rope Assembly 1/2"x75' EIPS	77534

Engineering Data			
Rated Pulling Force:	15000	lbf	6804 kgf
Drum Barrel Diameter:	4.00	in	102 mm
Drum Flange Diameter:	8.24	in	209 mm
Distance Between Flanges:	9.95	in	253 mm
Recommended Maximum Wire Rope Diameter:	1/2	in	12.7 mm
Recommended Minimum Wire Rope Breaking Strength:	26600	lbf	12066 kgf
Approximate Shipping Weight:	83.0	lb	37.6 kg
Duty Cycle (intermittent per SAE J706 section 6.2):	932	ft	284 m
Mounting Bolt Torque:	35 - 40	ft*lbf	47 - 54 N*m
Maximum Layers of Wire Rope:	3 (with 1/2" dia. rope)		
Gear Reduction:	36:1		
Brake Type:	Disk		
Contactor / Remote Type:	N/A		

### Drum Rotation

Viewed from Motor End

### Standards Compliance

- SAE J706
- CE Machinery Directive 98/37/EC and 2006/42/EC

### Performance By Layer- 1/2" (12.7 mm) dia. rope

Drum Layer	Line Load *			Line Speed 10 GPM		Line Speed 15 GPM		Drum Capacity	
	lbf	kgf	kN	ft/min	m/min	ft/min	m/min	ft	m
1	15000	6804	66.7	12.8	3.9	18.9	5.8	21	6.4
2	12273	5567	54.6	15.6	4.8	23.1	7.0	46	14.0
3	10385	4711	46.2	18.5	5.6	27.3	8.3	75	22.9

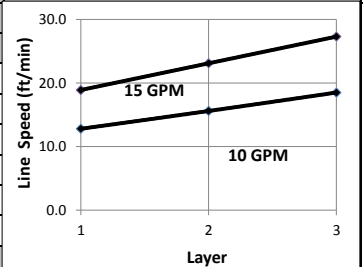

\* Never exceed the Rated Pulling Force. Installation of a Rated Capacity Limiter is recommended.

### First Layer Performance

Line Load		Pressure Drop at 10 GPM		Pressure Drop at 15 GPM		Duty Cycle
lbf	kgf	psi	BAR	psi	BAR	min/10min
0	0	218	15.0	362	25.0	N/A
3000	1361	547	37.7	664	45.8	N/A
6000	2722	904	62.3	1003	69.2	N/A
9000	4082	1279	88.2	1379	95.1	N/A
12000	5443	1672	115.3	1790	123.4	N/A
15000	6804	2150	148.2	2200	151.7	N/A

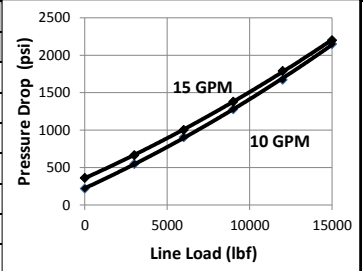

**WARN INDUSTRIES, INC**  
Industrial Products

Customer Service (North America): 1.800.543.9276  
Customer Service (International): 1.503.722.3008  
FAX: 1.503.722.3000 www.warn.com

12900 S.E. Capps Road,  
Clackamas, OR USA 97015



# WARN Industrial Winch

Model	Part Number	Motor Type
Series 15-A-59 Hydraulic Winch Manual Clutch	65931	Hydraulic 6.1 ci (100 cc)

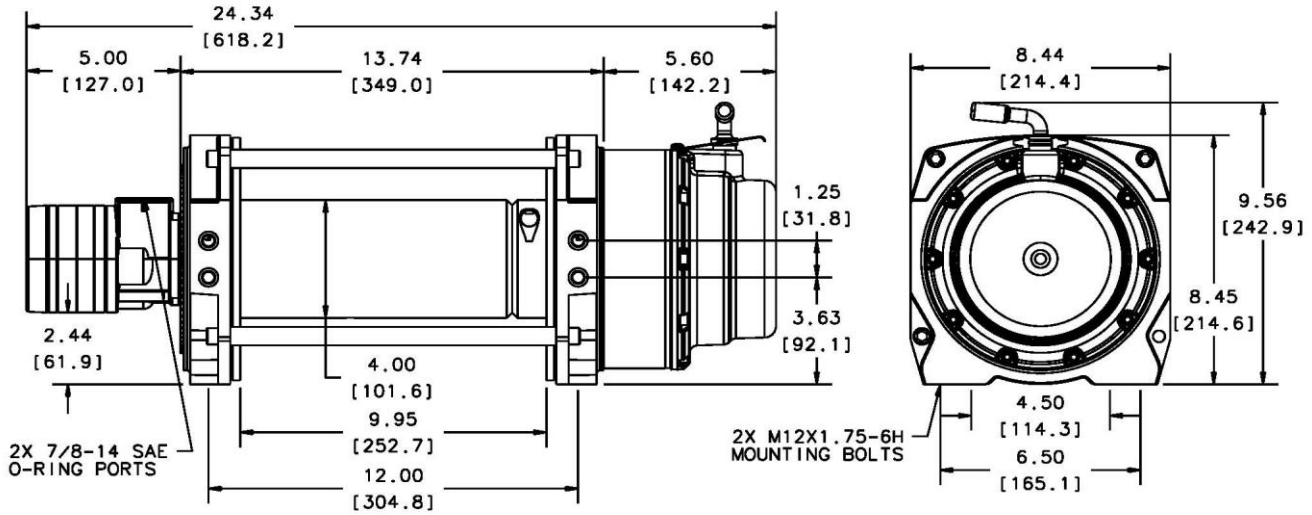

Motor / Contactor may be rotated in 90 degree increments. Clutch housing may be rotated in 72 degree increments.

Units are given in inches [millimeters], unless otherwise specified

Recommended Mounting- Always Observe Correct Drum Rotation			Hydraulic System Specifications		
Pull from bottom of winch	Pull from bottom of winch	Pull from top of winch	Maximum System Pressure:	2200 psi	152 BAR
			Maximum Motor Pressure Drop:	2200 psi	152 BAR
Feet down	Feet forward	Feet forward	Maximum Rated Input Flow:	15 GPM	57 LPM
Pull from top of winch	Pull from top of winch	Pull from top of winch	Control Valve Type:	3-position, 4-way, closed center, spring return (cylinder spool)	
			<b>Control Valve Schematic</b>		
Feet down without angle brace	Feet down with angle brace	Angle Braces Only			
			Note: Drum rotates clockwise with Port A pressurized when viewed from gearbox end.		

**WARN INDUSTRIES, INC**  
Industrial Products

Customer Service (North America): 1.800.543.9276  
Customer Service (International): 1.503.722.3008  
FAX: 1.503.722.3000 www.warn.com

12900 S.E. Capps Road,  
Clackamas, OR USA 97015