

8 7 6 5 4 3 2 1

D  
C  
B  
A

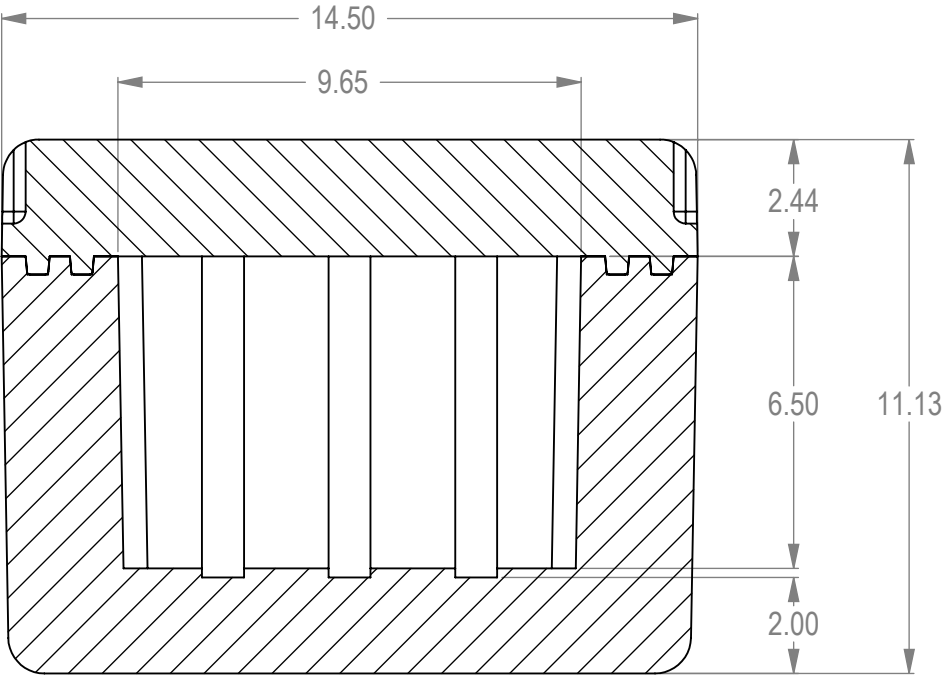

SECTION A-A

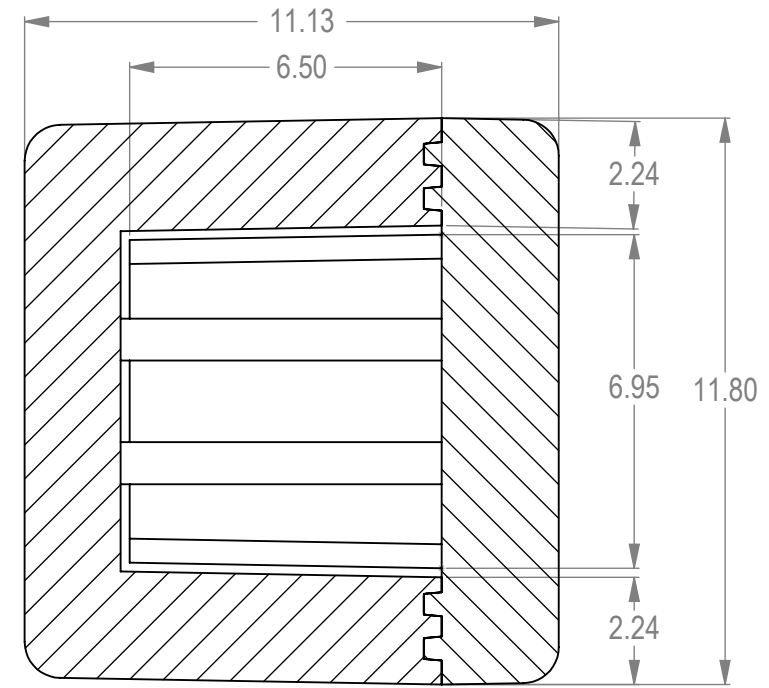
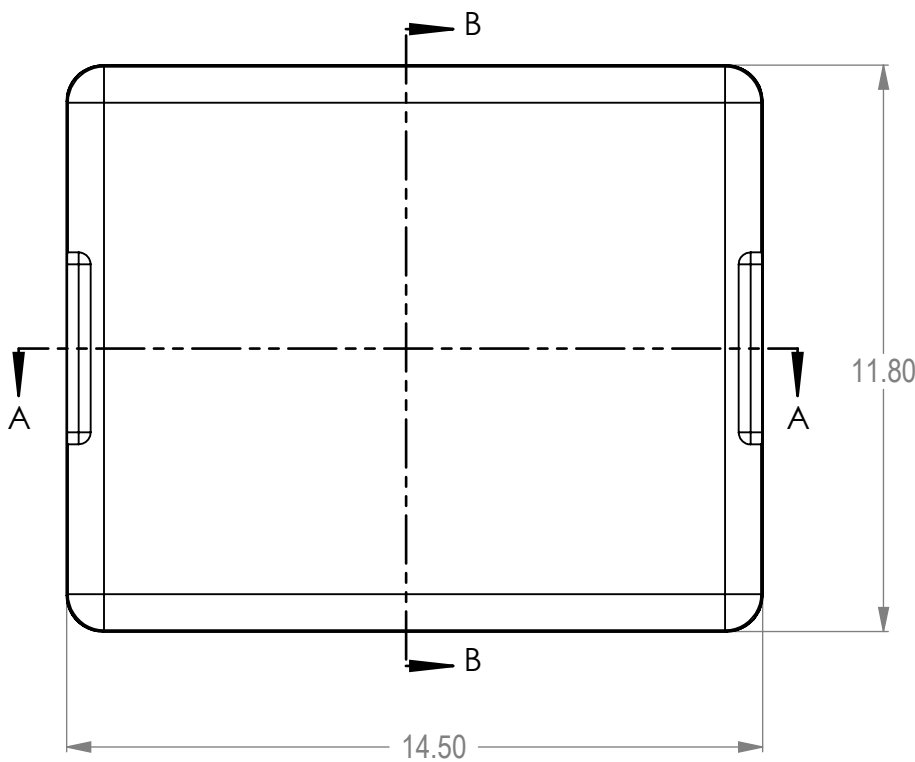

SECTION B-B

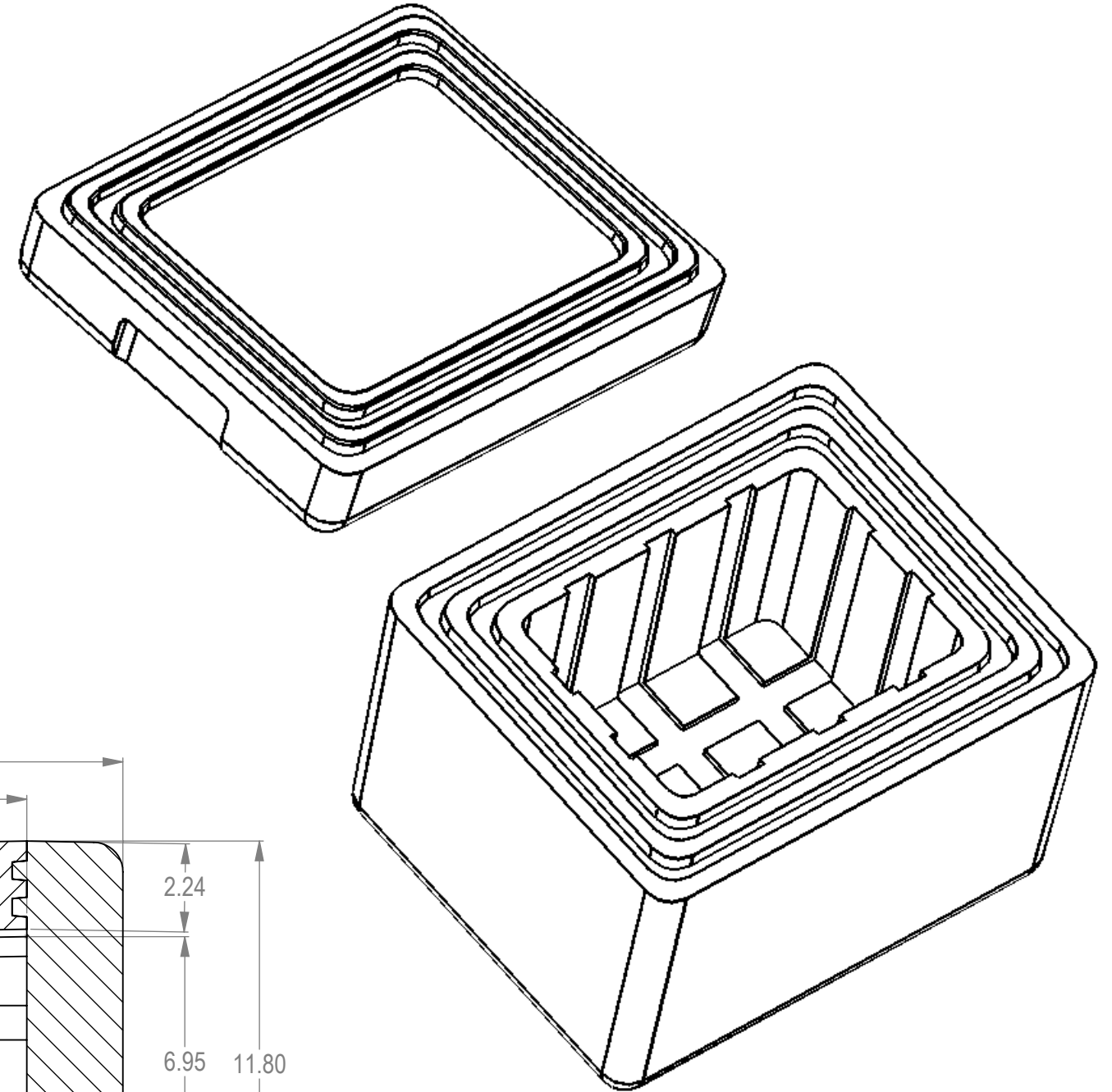

STANDARD EPS TOLERANCES FOR DENSITY 1.12 TO 3.0 PCF

DIM. INCH(MM)	TOL. INC(MM)
0.0 - 6.0(152)	+/- .039 (1)
6.0(152) - 12.0 (305)	+/- .06 (1.5)
12.0(305) - 24.0(610)	+/- .098 (2.5)
24.0(610) - 48.0(1220)	+/- .12 (3)
48.0(1220) - GREATER	+/- .20 (5)

<b>PROPRIETARY AND CONFIDENTIAL</b> THE INFORMATION CONTAINED IN THIS DRAWING IS THE SOLE PROPERTY OF <b>marko foam production</b> . ANY REPRODUCTION IN PART OR AS A WHOLE WITHOUT THE WRITTEN PERMISSION OF <b>marko foam production</b> IS PROHIBITED.	DRAWN	NAME	DATE	
	CHECKED			
	ENG APPR.	Ilir Bordoniqi	04/14/10	
	MFG APPR.			
	Q.A.			
MATERIAL	EPS 1.25 PCF			COMMENTS: CAVITY VOLUME V=395 cu. in.
FINISH	DO NOT SCALE DRAWING			
SIZE DWG. NO. <b>A</b>				
SCALE:1:4		WEIGHT:		REV. SHEET 1 OF 1

8 7 6 5 4 3 2 1