

SPJ-WM800

Accent

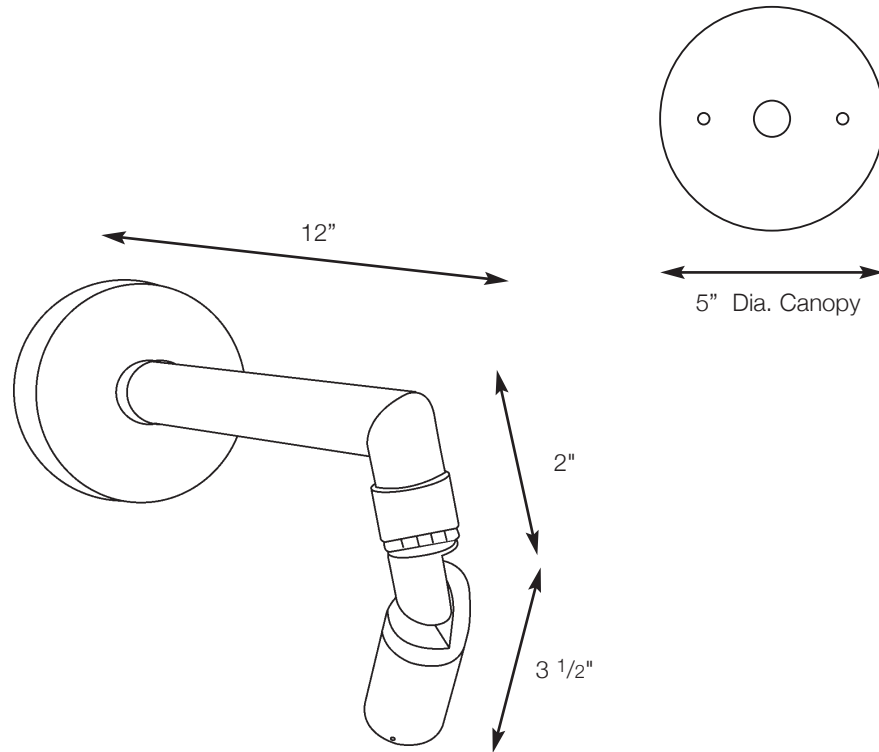

- MODEL:** SPJ-WM800
- MATERIAL :** Solid Brass
- FINISH :** Specify
- GLASS :** Specify
- ELECTRICAL :** 12v
- SOCKET :** Bi-Pin
- LAMP :** 50w Max.
- MOUNTING :** Wall Mount or 1/2" NPT
- OPTION :** SPJ14-51 Shroud



Specify Wet Location



DRAWN BY: MMC

BASE DESIGN: SPJ

DATE: 01-10-10

SPJ LIGHTING INC.

2107 Chico Avenue
South El Monte, CA 91733
(800) 469-3637 FAX: (626) 433-4839