



Tel: 626-246-1094 • 800.414.5109 • Fax: 626-443-0267

SPECIFICATION SHEET

SPJ-PM9090

Pendant

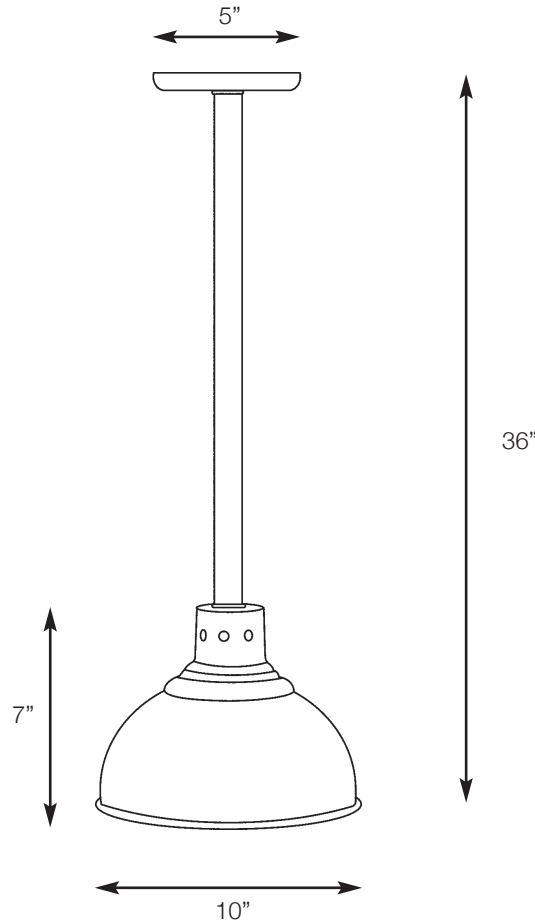

MODEL: SPJ-PM9090
MATERIAL : Brass or Steel
FINISH : Specify
ELECTRICAL : 120v - 277v
SOCKET : Specify
LAMP : Specify
FLUORESCENT OPTIONS : PL-13W, PLT-26W, PLT-32W, PLT-42W



DRAWN BY: MMC

BASE DESIGN: SPJ

DATE: 01-10-10

SPJ LIGHTING INC.

2107 Chico Avenue
South El Monte, CA 91733
(800) 469-3637 FAX: (626) 433-4839