

Hoist-A-Top Simple[®] Installation Instructions



Safety Requirements

Please Read!!!

Please thoroughly read and understand these instructions before installing your Hoist-A-Top® and before lifting your top.

When installing the Hoist-A-Top® remember safety first! Make sure you use proper safety equipment when installing this product. Use gloves and eye protection. Be careful on ladders. If you are unsure about installing this product consult a professional or call us at the factory.

Cautions:

- Make sure your garage or structure is capable of supporting the weight of your top. If there is any question about your structure's integrity, consult a professional.
- Before lifting your top make sure that all hardware is properly fastened to the center of your studs in your wall and ceiling. Wire clamps must be checked and tightened regularly.
- Do a dead weight lift to initially test your installation.
- Upon lifting your top for the first time and subsequent times thereafter visually and check that all hardware including but not limited to wire clamps, elevator bolts, hooks, wire cable, crank hoist, and lifting strap. Make sure all are tight and in good working order.
- Lange Originals is not responsible for damage or personal injury due to improper installation, custom installation that doesn't follow the instructions, or neglect to inspect equipment prior to using equipment.

If you need help for any reason **DO NOT CALL YOUR DEALER** Please contact us direct at the factory. We can help with missing parts or for help with installation.

Call toll free 1-866-284-7428 or email at contact1@langeoriginals.com

Parts list:

1 strap



2 single line pulleys



1 double line pulley

1 43 foot cable

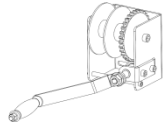

1 crank unit



2 rubber coated hooks (black for JK and YJ
Red for TJ)

One hardware bag containing:

4 wire cable clamps

X4



x4



2 wire thimbles

X14



x2



14 wood screws for attaching pulleys

2 elevator bolts

X2



x2



2 wing nuts

x2



x2



2 flat washers

2 standard 5/16 nuts

2 3 inch lag screws for attaching crank to
the wall

Tools and supplies needed:

9/16 socket

11/16 socket

5/16 socket or nut driver

Electric screw gun

Stud finder (optional)

Level (optional)

2x6 8 feet . (If your studs are not at 16
inch centers you will need a longer 2x6.)

3.5 to 4 inch long screws to attach the 2x6
to your wall and ceiling. (approx. 20)

Call toll free 1-866-284-7428

Langeoriginals.com

Copyright Lange Originals

Section A

Installation of the crank unit

1. Remove the spool from the crank unit using the 11/16 and 9/16 socket
2. Cut one section of 2x6 to 20 inches. Mount it to your wall using at least 4 screws (at least two in each stud) aprox. 50 inches above the floor.
3. Mount your crank unit to the center of the 2x6 using the 2 3 inch lag screws and washers provided.

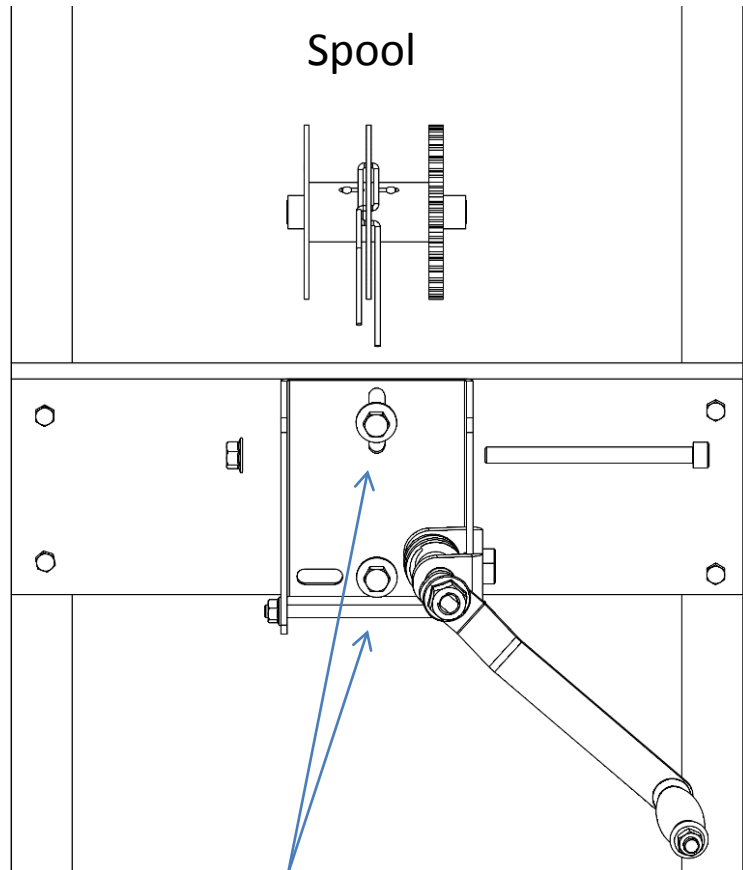

3 inch Lag screws & washers

Section B

Pulley installation

Determine if your studs run perpendicular or Parallel with your garage door. If your studs run perpendicular to (or the opposite direction as your garage door) please see section D.

1. With the mounting screws provided, mount the double pulley and one of the single pulleys in the center of your 2x6.
2. Mount the second single pulley $\frac{1}{2}$ inch left of center on the 2x6. This will allow the second cable to run along the ceiling without interfering with the other cable.
3. Mount the 2x6 with the double pulley in the top corner of the wall or the ceiling directly above the crank unit. See page 6
4. Measure the distance from the wall to the back of your jeep where you plan to lift the top. Mount the 2x6 with the single pulley centered at this point. (this will be the rear of the Jeep or the hook side) see page 6
5. From the center of the middle 2x6 measure over 34 inches and install the 2x6 with the single pulley that is left of center. (This will be the strap side)see page 6

- Hint:
- It may be easier to put in the screws when the wheels are removed

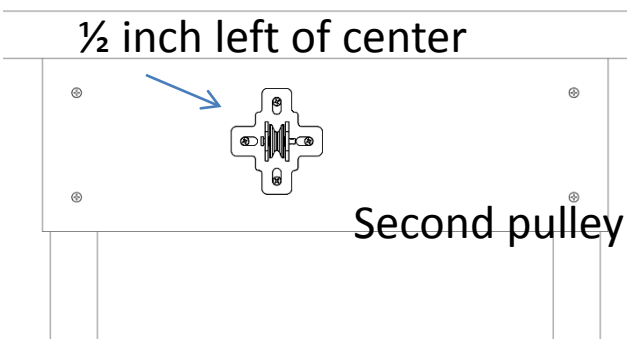
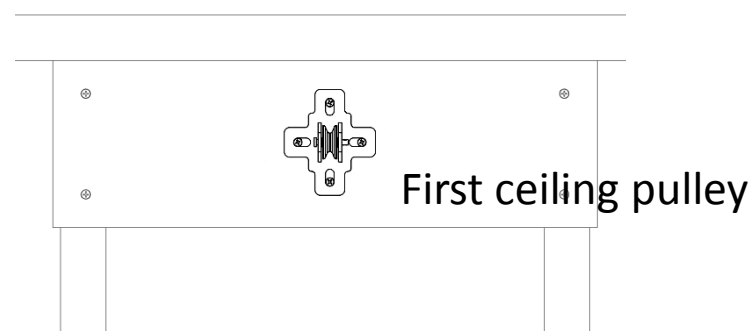
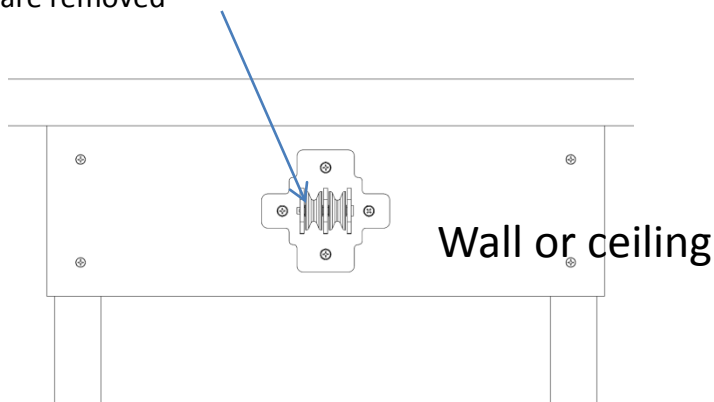

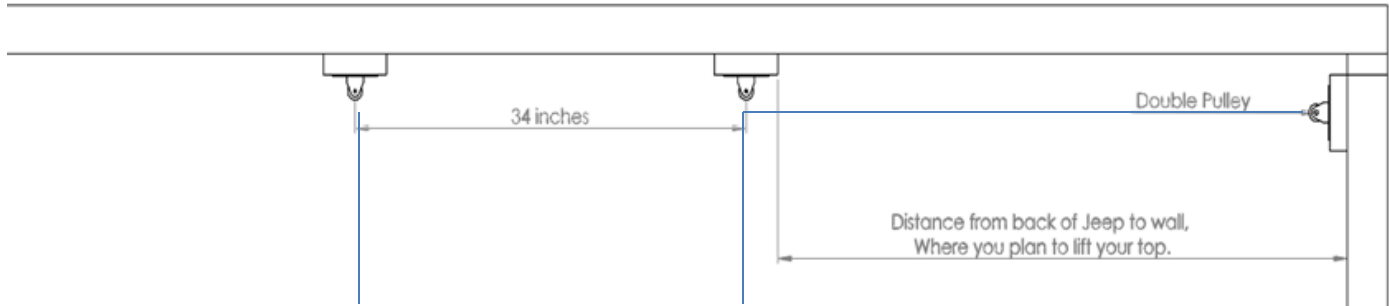

Strap (long cable)

Hook (short cable)

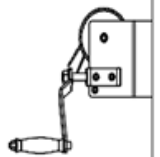
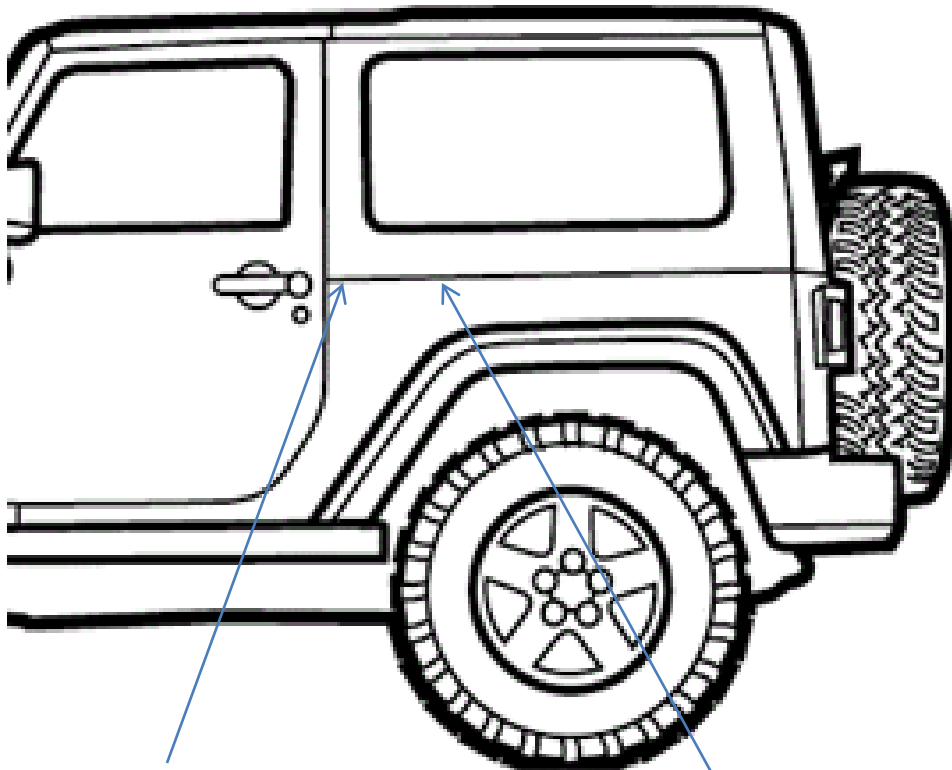

Four door strap hole

Two door strap hole

Section C

Installing the lifting hardware

1. Unclip the wire bundle and stretch out the wire. The cable is 43 feet in total. 23 feet for the right side of the drum (the strap side) and 20 feet for the left side of the drum (the hook side)
2. Mark the cable at the 23 foot line with a marker or piece of tape. Center your mark in one of the large holes and lace one of each side of the cable through the two smaller holes. You should finish with the longer cable on the right side of the spool.
3. Loop both wire ends through the double pulley in the corner of the ceiling. Take care that the cables don't cross and that the long side stays on the right pulley and the shorter side stays left.
4. Pull the left side cable through the middle single pulley in the ceiling. This line will be for the hook.
5. Pull the right side cable through the front pulley (this should be the pulley that was installed ½ inch left of center) This cable will attach to your front strap.
6. Attach the Smart Hook® to the cable coming from the center pulley(left cable) use the Red hook for a TJ (1997-2006) Jeep or the black hook for JK (2007-present) or YJ (1987-1995) Jeep. Please see illustration to the right for proper wire nut installation.
7. Install the lifting strap on the front cable (right).
8. Install elevator bolts into the holes on the Jeep top. If you have a 4 door JK this will be the last holes on the front. If you have a 2 door JK, TJ YJ or CJ this will be the second hardware hole from the front door.

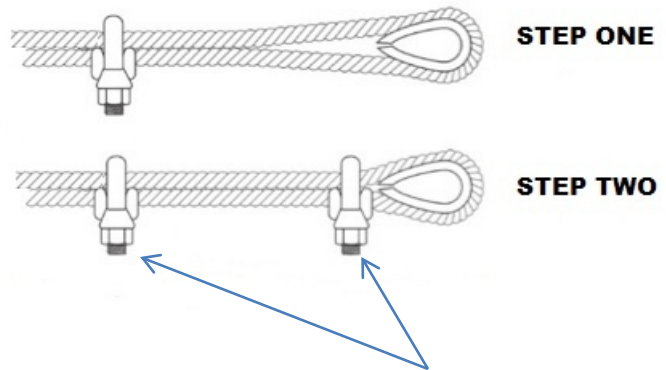
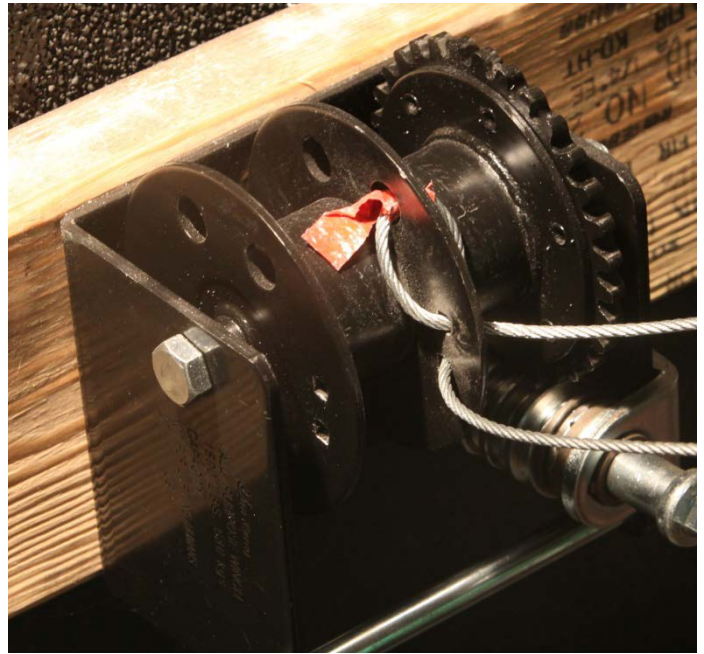

CAUTION:
Tighten all bolts securely
Before lifting top!!

Section D

Lifting your top and Storage

1. Before you lift your top Test all connections make sure hardware is secure in the ceiling and bolts are tight.
2. Back your jeep into the lifting position . The rear Smart Hook® should hang in the middle of the window and barely touches the glass.
3. Release all hardware holding down the hardtop and remove the Freedom Top® panels. Take care to unplug your wiring harness in the back of the jeep.
4. With one hand or with the help of a friend, by the rollbar at the top, slightly Lift one front corner of your top and slide the lifting strap in between your top and the body of the Jeep. Slip the grommet over the elevator bolt. Hand tighten the wing nut To hold the strap in place. Repeat on the other side. *note the 2 door will use the second set of holes in from the door see page 6 to locate proper holes*
5. Open your rear window and put the year appropriate hook between the glass and your top. Carefully close your rear window.
6. Turn your crank clockwise to begin lifting your top.
7. You may need to adjust the length of the cable attached to the Smart hook®, or to the lifting strap by loosening the wire clamps and adjusting the length of the cable.
8. Do not over lift your top and put undue pressure on the pulleys.

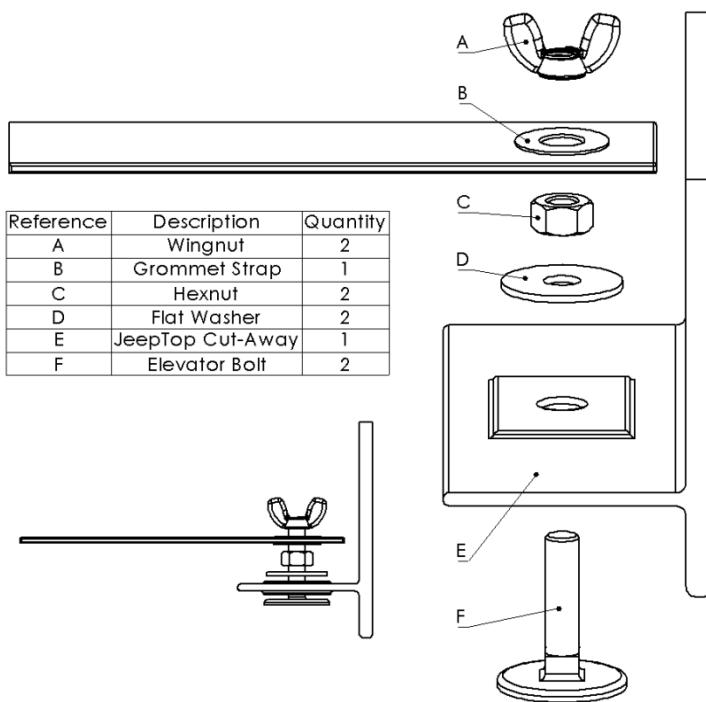

Section E Perpendicular beam installation

If your beams run perpendicular to your garage door you need to run your 2x6 piece differently

1. Cut your 2x6 approximately 50 inches long.
2. With the provided hardware attach both single pulleys on the 2x6 34 inches from each other. Make the first pulley on center and the second pulley $\frac{1}{2}$ inch left of center. This will allow the cables to run next to each other without interference.
3. Mount the double pulley on a 20 inch 2x6. You can mount your double pulley on the ceiling or at the top of the wall. Attach your 2x6 to three studs in line with the double pulley in the corner of the wall.
4. Proceed to section C.

Hint:

It may be easier to put in the screws when the wheels are removed

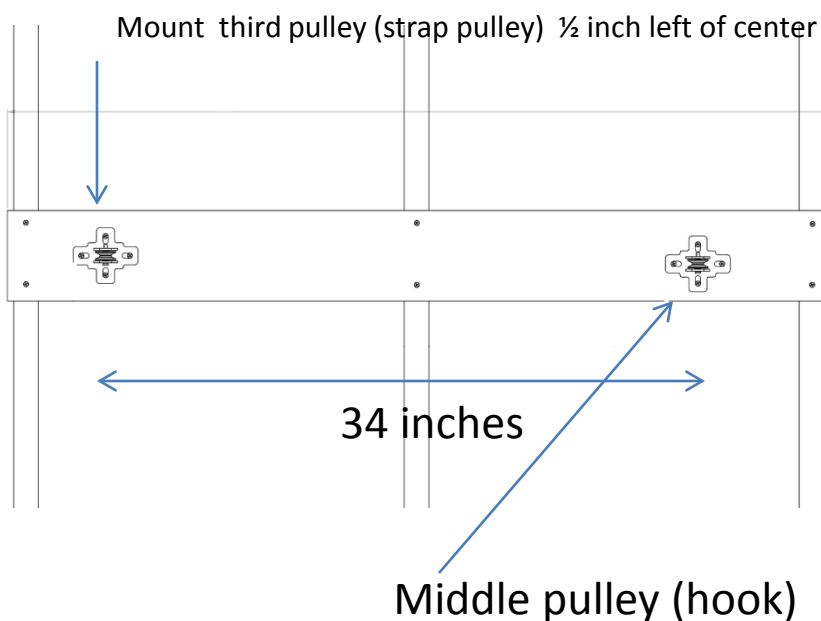
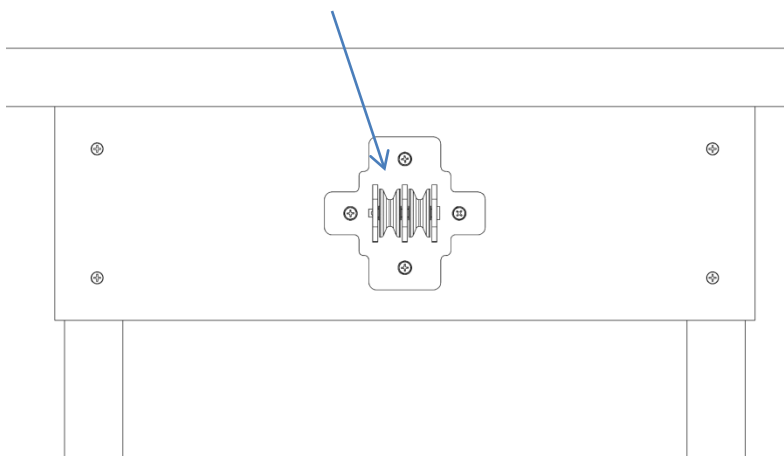

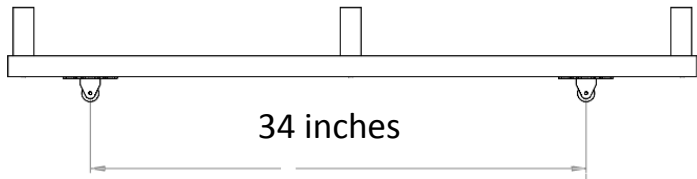

This distance is only limited by the remaining length of your cable

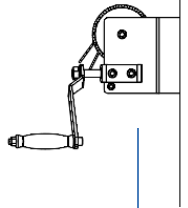
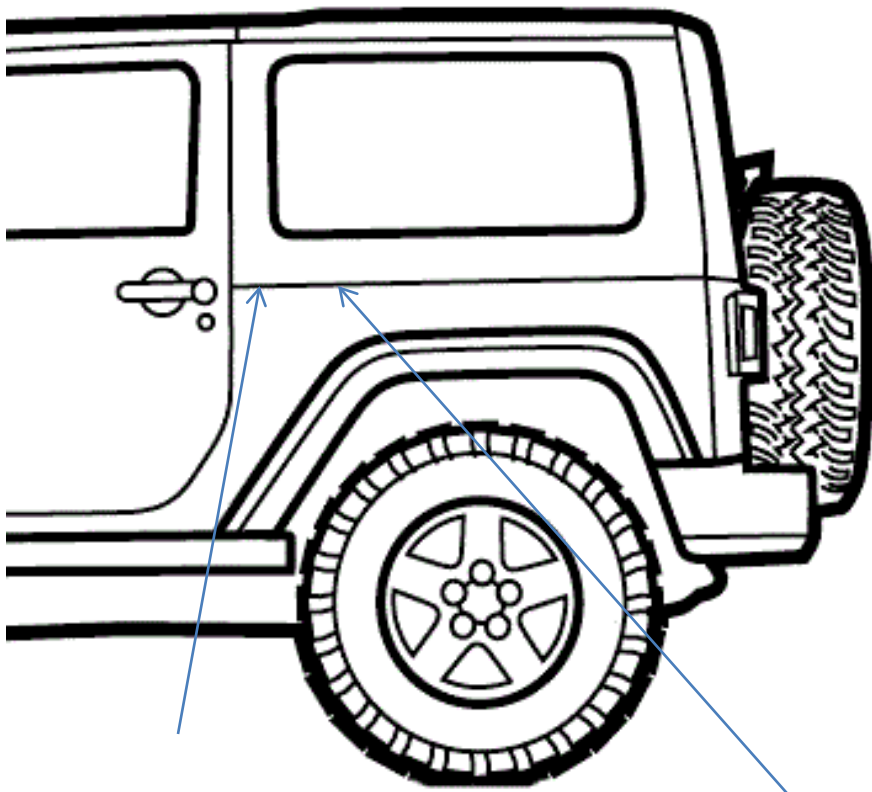

Aprox 50 inches

4 door hole

Two door hole

Warranty

We want you to be as happy as we are with our products. Give us a call if you're having trouble and more than likely we'll be able to help you with it. We have been lifting tops for 26 years now and have heard about anything. 9-5 MST is the best time to catch us, but if we miss you leave a message and we'll get right back to you.

We honor a one year warranty from the date of purchase on this product if installed and operated according to these instructions. This warranty is invalid if purchased through an unapproved third party or a unregistered dealer. This warranty covers parts if found defective but does not include: abuse or damage due to neglect or misuse. Liability for any application for the product is limited to the replacement or repair of the product itself and does not cover consequential damage or injury. Use at your own risk.

Please call customer service at 1-866-284-7428 for warranty returns and help. If your product is out of warranty and you need a part, give us a call we can replace most items at a moderate cost to our customers.

About Lange Originals®

Lange is a family started, owned and run business. Our first Hoist-A-Top was invented when removing a hard top on our new jeep someone slipped and dropped the top, an idea was planted. Original prototypes were made from wood and then metal. We started with a 2x2 advertisement in a 4x4 magazine, and now ship our products world-wide. We appreciate your business and support; It's put young people through school, braces on teeth, and roofs over our heads. If there is anything we can do to continue to have your business, please let us know.