



Addendum for JL Jeep Hoists

This is to explain the procedure to put the rear hook on the Jeep top. Due to the unique shape, and tolerances between the glass and the top edges of the window frame the rear hook must be set in place before attaching to the frame.

Step 1: After assembling your frame and attaching it to the lifting mechanism Place the assembled frame on the top of the Jeep WITHOUT the patented rear JL hook attached.

Step 2: With the window open, take the hook under the window and through the gap carefully with the threads up (fig 1.) Put threads through the hole in the frame (fig. 2.)



Fig. 1

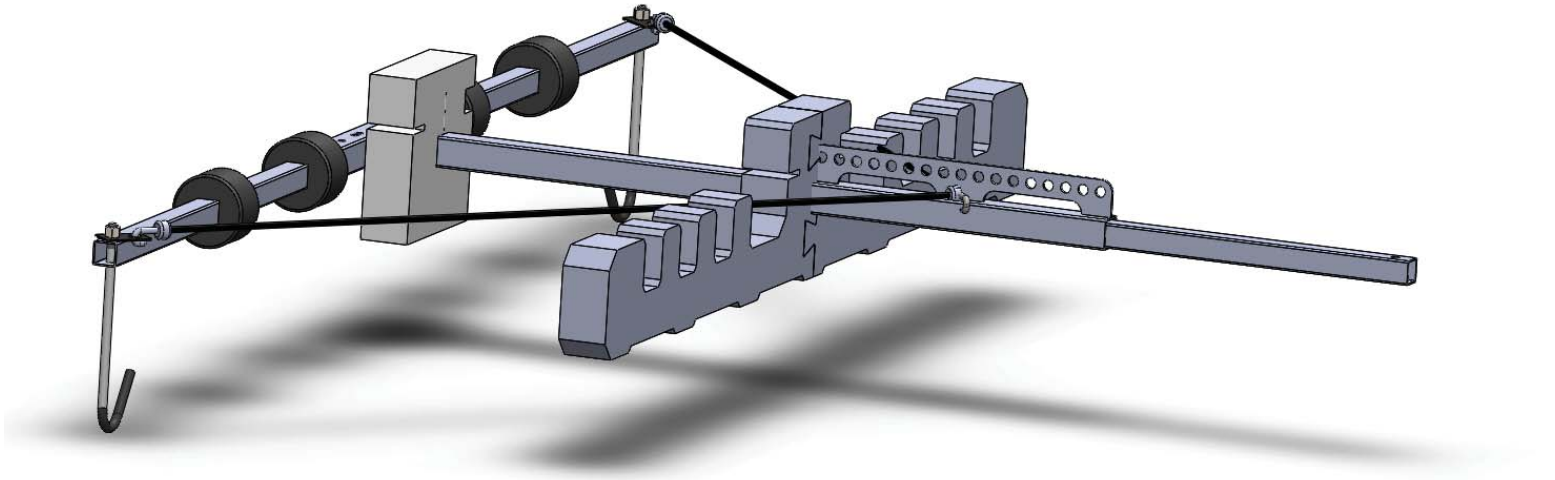

Fig. 2

Step 3: Using the wing-nut thread it on the hook until you can see three to four threads out of the top of the wing-nut. Do not over tighten this causes uneven lifting.

IMPORTANT ADDENDUM TO INSTRUCTIONS

There is also a change with the foam from the instructions. The JL foam pieces need to be put in front of the lifting blade as pictured here instead of the back of the lifting blade, also to note is the front foam is shaped slightly different than the pictured foam in the instructions. If looking at the back of the frame the small slot on the foam should be oriented on the left, or driver side.



HOIST A TOP®

Parts List

This list may include optional items from other Hoist-a-Top® systems as well as a list of common parts included in all hoists. Parts are listed by part number, description, and quantity. The part number may be referenced in the instructions designated by parenthesis () for your convenience.

Part Number	Description	Qt
Common Parts (All systems have these parts)		
1	Support Arms	3
2	"T" Section	1
3	Black Foam Holes	3
4	Plastic End Caps	3
5	"J" Hooks	2
6a	Rear "Smart Hook™" JK only	1
6b	Rear Hook for CJ/YJ/TJ only	1
7	Nyloc Nuts	3
9	Ceiling Pulley	1
10	Wood Screws	4
11	Wood Screws For Cross Brace	8
Power Unit Additional Parts		
1a	110V Winch	1
2a	Large Eyelag	1
3a	Mounting Bar	1
4a	4" Lag Screws	2
5a	Wire Clamps	2
6c	3/8" Washer	2
7a	Pulley(included in Power box)	1
8a	"Quick Link"	1
Optional Parts for JK Jeep Hoists 2007-2018		
1d	Black Foam Hole	1
2d	Foam "T" Support	1
3d	Long Foam Support Arms	2
4d	Strap w/Grommets	2

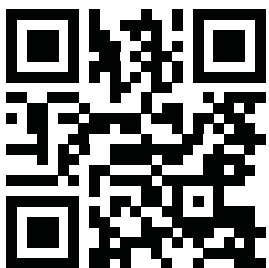
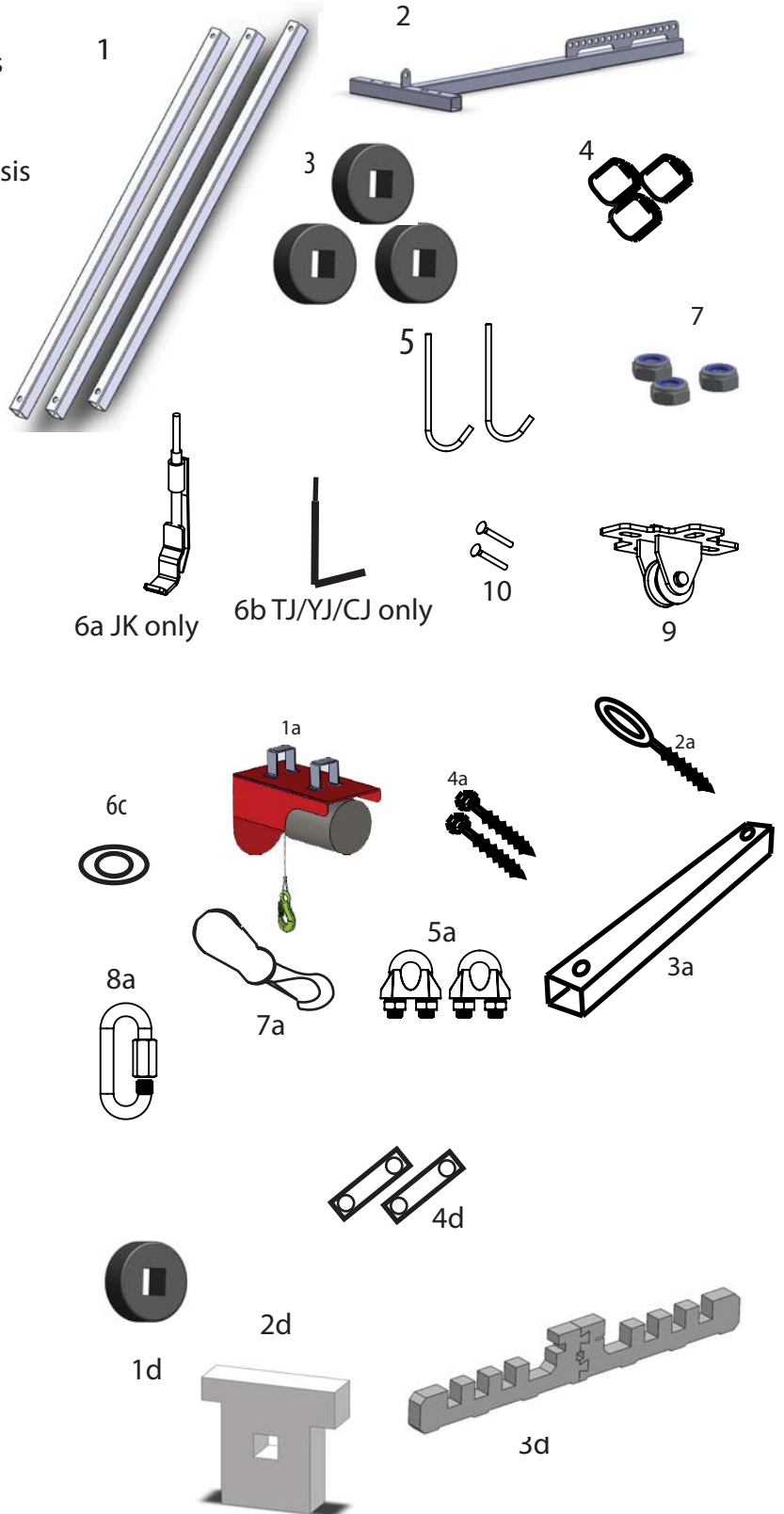

Scan with Android QR scanner or Apple QR. Don't have a qr scanner? Search Google Play or Apple Store for QR Code Scanner. Scan the code and follow the URL to play the video instructions.



Lange Power Unit Installation Instructions

Tools needed: Safety glasses , gloves, screwdrivers, socket wrench set with driver and sockets, drill, standard drill bits, stud-finder, and a wood saw.

Installation Time: 1-3 hours depending on experience

Installation Difficulty: 3 out of 5. Person should have a basic knowledge of common household tools and be able to find a wall stud without difficulty. Specialized tools not required. Note that text underlined in the installation guide are found in a glossary of terms in the back of the guide.

Lifting Cautions

Never lift your top so it is tight against the ceiling. This puts undue stress on the top and the Hoist. Keep your body, especially your hands away from edges of the top. We recommend you push or pull the top from the side and not use the bottom edge. There is a natural tendency to align the top with your fingers under the edge.

Periodically check nuts and bolts on the Hoist-a-Top® system for tightness. Also, inspect the ceiling mounting points for damage, or bent parts. Tighten power unit motor bolt to prevent oil leaks.

All Garages are different. Carefully read and watch the video and written instructions before installing. If you are unsure or uncomfortable with installing this product contact a structural professional. Always test this mechanism using a static and live load. Never stand, allow children, or pets under a lifted object on this mechanism. Misuse or improper installation of this product can result in serious injury or death. Follow all safety rules and regulations of tools and ladders while installing this product. Wear safety glasses, gloves, and boots while installing this product. Never walk under or allow others to either play , stand, or work under the top.

If you need help or are missing a part **DO NOT CALL YOUR DEALER. You will receive faster support though the factory 1-866-284-7428** We offer technical support Monday through Friday 9:00 AM to 4:30 PM Mountain Standard Time. Send us an inquiry via our website hoistatop.com anytime, or contact1@langeoriginals.com. No question or problem is trivial so we'll try and help any way we can. We use these products ourselves and like them, we hope you will too. Lange Originals® is not responsible for damage or personal injury due to improper installation, custom installation that doesn't follow the instructions, or neglect.

There is an online video that is extremely helpful for this product. Most questions are answered visually by watching us do it in the video, by scanning the QR codes, for that specific section, with your phone . You can also browse to langeinstructions.com, or search You Tube for *Lange Power Hoist A Top Install*. We also have a section in the video for removing the hard top latches and wiring etc., which can be tricky the first couple of times.

Warranty: This product has a 1 year limited warranty from the invoice date of purchase for defective parts only. Lange will repair or replace parts at their discession. For full warranty information please see langeoriginals.com and click on warranty, and find your specific ordered part number. Valid invoice/receipt required.

Site Preparation

Determine whether to do either a side wall mount, or a directly-over-hardtop ceiling mount. The determining factor of this is ceiling height. Garages with a 7-9 ft ceiling require a side wall installation. Garages over 9 ft tall should use an overhead ceiling mount configuration. If your ceiling is vaulted, or abnormal (anything other than parallel to the floor) consult a contractor/professional, you may need to build additional supports for your power unit.

Plug your power unit into a wall and test it up and down while holding the cable centered in the fair-lead before beginning installation.



Site Prep video walk-through. Scan or enter this URL to watch on your phone or computer.
<https://youtu.be/QtTCFGyVK5Q?t=2m56s>

Ceiling Mounting

Mounting the power unit overhead: Back your Jeep into your garage in a suitable location to lift your top and still open your rear tailgate. To determine a suitable lifting point from the ceiling, run a plumb-bob from the center of your hardtop to the ceiling and make a mark with a pencil. Using either a stud-finder or your preferred method, determine the closest stud/TJI and set a ceiling mark.

Note: TJI's are usually present when living space is above the garage for homes built after 1985. TJI's should not be drilled into and require cribbing cross bracing



A typical ceiling installation with a 2x6 cribbed cross section securely fastened with 4,4" framing screws. Note the claw hook at the end of the line clips back into the housing and the safety stop is loose on the fair-lead side.

with a 2x6 or wider. Cribbing is the preferred method on all ceiling installations. After you've found a stud near the point we've determined to be center with the plumb-bob find the closest parallel stud to it. Crib the two studs with a 2x6 or wider piece of good lumber. Install "U" brackets on the back of the power unit using the provided bolts and lock washers that are in your power unit box. Using a 15/64" drill bit, use your mounting bar (3a) as a template to drill pilot holes into your cribbed cross brace and install one side of the mounting bar fairly loosely with the lag bolt (4a). (With a helper) slide power unit onto the open side of the mounting bar. Thread the other lag bolt(4a) with washer through the mounting bracket hole, and into the pre-drilled wood cross brace. Alternate tightening bolts until they are snug. Do not over-tighten lag bolts. Extend the cable to release some slack, and fasten the hook on the end of the cable to the power unit (there is a cut hole in the red casing for this purpose). Let down some slack so you can install the hook/pulley (7a). Now, remove the hook and discard. Do this by removing the bolt holding the hook, discard the hook and replace the bolt and nut. Use this to attach the line and pulley to the lifting blade. Now, remove the pulley wheel from this assembly and place in-line between the ceiling pulley and power unit. Tighten and inspect all nuts on the pulley assembly. Test the power unit with a dead load (person or dead weight such as a hundred pound bucket). If the frame system hangs 180° out, it will rotate your top. To fix this, install the quick-link (8a) on the end of the pulley (see page 5 for a photo).

Sidewall mounting

Back your Jeep into your garage and determine a suitable lifting point from the ceiling. Run a plumb-bob from the center of your hardtop to the ceiling and make a mark with a pencil. Using either a stud finder or your preferred method determine the closest stud/TJI from your mark. TJI's are usually present when



Install one side of the mounting bar fairly loosely with the lag bolt (4a). (With a helper) slide power unit onto the open side of the mounting bar.



Scan here to show video of us doing a ceiling mount. <https://youtu.be/QiTCFGyVK5Q?t=2m56s>

living space is above the garage for homes built after 1985. TJI's require cribbing cross bracing with a 2x6 or wider, and then screwing the pulley (9) into the 2x6 with six wood/framing/decking screws at least 3" long. If a stud is in the approximate location of where you plan to lift the hardtop, screw the pulley with the wheel pointing toward the wall where the power unit mounts. Use two screws centering the stud.



After preparing the ceiling and installed a pulley, draw a straight line to the side wall or back wall to locate the power unit.

Next, determine the distance between wall studs. If they are on 16 inch centers, use Power Unit Mounting Bar (3a) as a template. Mark holes and drill 15/64" pilot holes into your studs. For 24" centers use a 2x6 to mount the Bar (3a).

Plug in and test your power unit, making sure you guide the cable out through the center of the fair-lead. Your power unit should be mounted as close to the ceiling as possible, in our video we mount the Mounting Bar (3a) 3 1/2 inches from the ceiling. Use a 15/64" drill bit, drill pilot holes into your 2x6 crib. Install one side of the power bar with the lag bolt (4a) and 3/8" washer (6c). Only install this 1 lag bolt turned a few threads in, enough to stay in the wall while you get the power unit. Install "U" brackets on the back of the power unit using the provided bolts and lock washers that are in your power unit box. With a helper slide power unit onto the open side of the mounting bar. Thread the other lag bolt/washer in the wall on the other side of the power unit. Alternate tightening bolts until they are snug. Do not over-tighten.

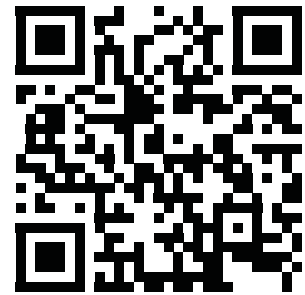

Scan here to video to wall mounting the power unit.
<https://youtu.be/QiTcf-GyVK5Q?t=8m3s>

Once the power unit is firmly attached, plug it in and pull the cable out to reach the center

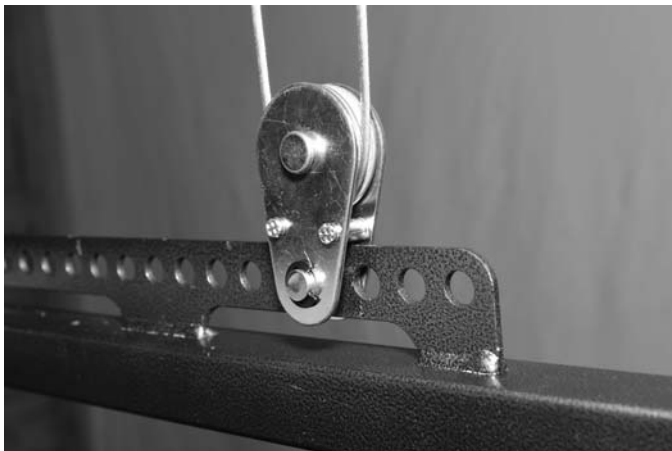

mounting pulley in your garage. Note that the cable will not go up if the stop fair-lead is interfered with. The Power Unit must be mounted at 90 degrees in line with this pulley to work properly.

Now remove the pulley wheel from the pulley and hook. Note: Remove the sear clip with pliers or a sear clip tool. Remove the center axle and replace while running the line through the pulley assembly. Make sure the safety stop (the red hockey puck) is on the same side of the cable as the power unit (closest to the power unit).

Now install the eye-lag (2a) in-line with the previously mounted pulley (9) and center in a stud

no less that 3 inches away. Drill a 9/32" hole in the rafter and tighten the eye-lag until you can't see threads. Keep in mind that the center of the pulley and eye-lag are your lifting point for removing the top. Clip the end of the Power Unit's safety hook into the eye-lag you've just installed. Let down some slack so you can install the hook/pulley (7a). The hook must be removed and discarded. To do this, remove the bolt holding the claw hook, discard the hook and replace the bolt and nut. Note: This is what will attach the cable to the lifting blade. Remove the pulley wheel from this assembly and place in-line between the ceiling pulley and eye lag bolt (see photo). Tighten and inspect all nuts on the pulley assembly. Test power unit with a dead load using either a person or a 100 pound weight.

During this process it's also a good idea to set the length of the safety stop (weighted red/black plastic or metal hockey puck). Lift the frame (after you've assembled it) as high as you want your top to hang and install the safety stop at the base of the power unit fair-lead and secure it in place by fastening the cable clamps tightly on either side of the safety stop. If the frame system hangs 180° out install the "quick link"(8a) on the end of the pulley to straighten out frame. The safety stop

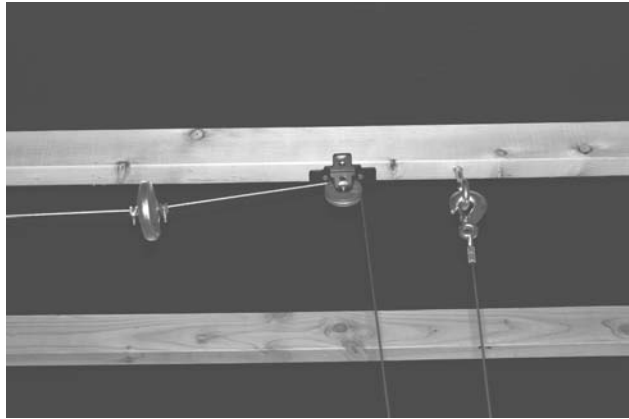

Safety stop, ceiling pulley, and end claw hook mounted in the lag bolt.

hits the fair-lead and auto-shuts off the power unit.

Frequently asked questions about power unit installation:

Q: What if my ceiling studs run parallel to the wall mount I'm installing instead of perpendicular as shown in your pictures?

A: Please see the diagram below

Q: On a ceiling mount can I rotate the power hoist to accommodate my studs being perpendicular or parallel with the garage door opening?

A: Yes, you can rotate a ceiling mount to accommodate your studs. As long as the cable doesn't interfere with the fair-lead.



Shown with optional "quick link" (8a) to rotate the frame 180 degrees

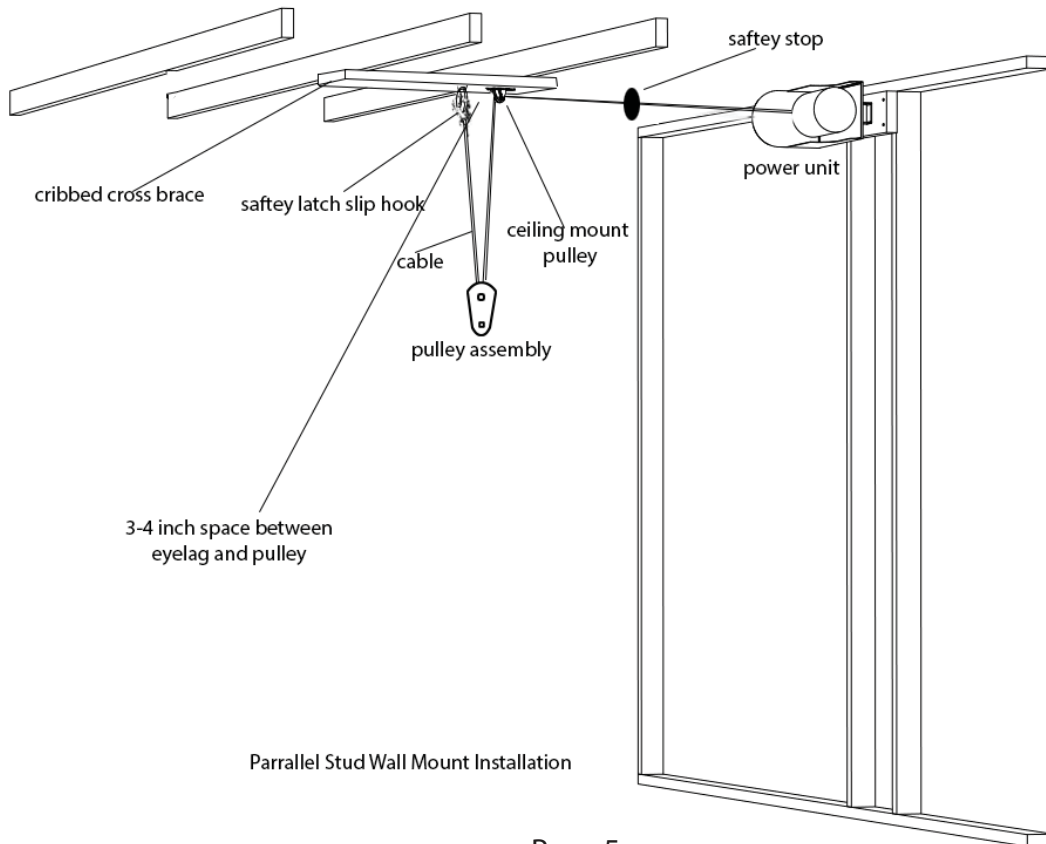

HOIST A TOP[®]

Frame Assembly

Begin frame assembly by locating the T shaped bar (2) depressing the spring buttons and sliding the front arms (1) into the T shaped bar with the spring button facing up (corresponding with the drilled holes in the T) and moving them to the appropriate holes (see frame assembly fig. 3). Slide the black round foam pieces on the arms. These will protect your Freedom Top pieces from touching the frame and space the frame from your hardtop. The black round foam pieces should be spaced directly under your freedom top pieces when the system is used to store them. Slide the "T" shaped white foam piece (2d) onto the base of the metal frame. There is a slit that allows you to do this. Pay close attention to the direction of the "T" foam in figure one, and orient it likewise. Put the rear bar (1) with spring button facing down, into the base of the metal T and click the spring button in the corresponding hole for your Jeep (Fig. 4). Put the J hooks in the front holes through one side of the grommet strap (4d) and thread nyloc nuts on so that 2 threads are past the nylon part of the nut. Find the rear Smart Hook™ and attach it to the rear arm of the frame by threading it into a nyloc nut until 2 threads show. Hook bungee cords to grommet straps, and any free hole in the lifting blade. Assemble long foam supports (3d) on the rear arm sliding the dovetail pieces together and the rectangle lined up with the rear arm. Insert plastic end caps.

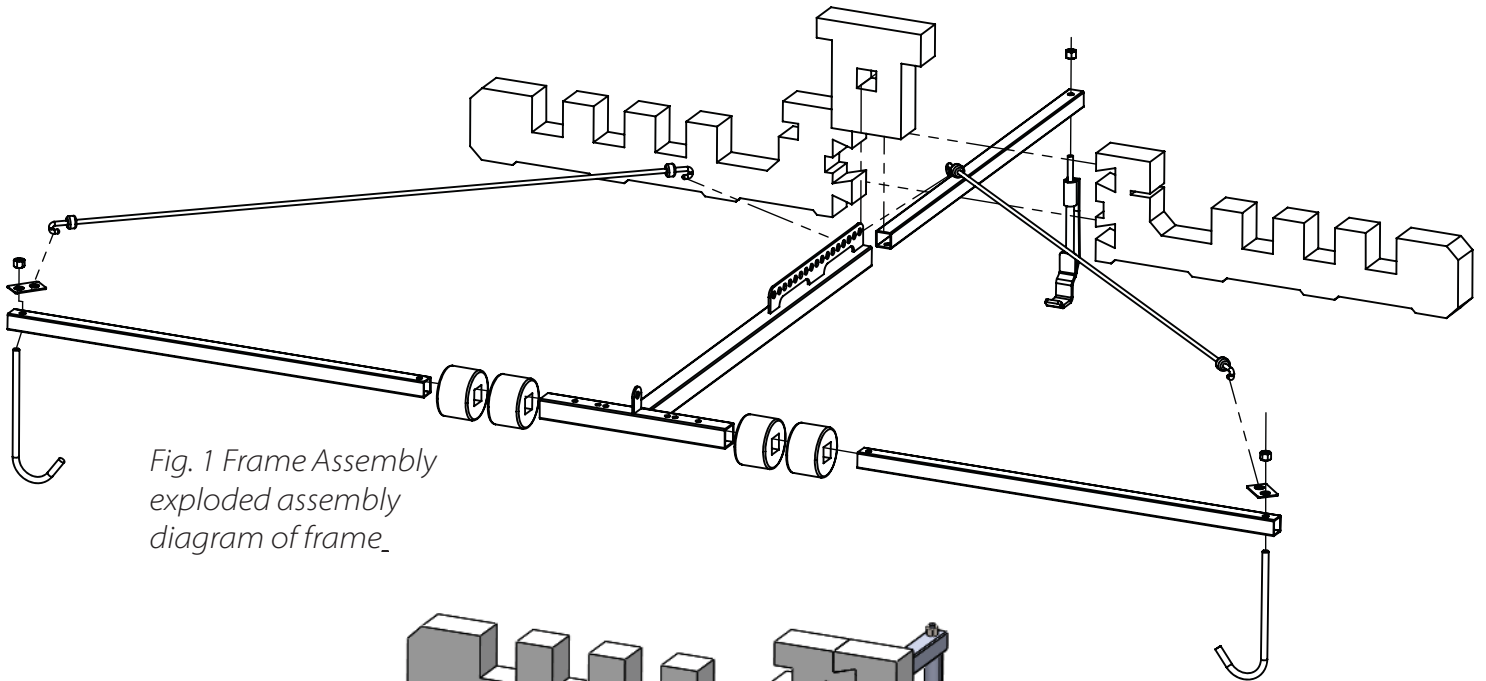

*Fig. 1 Frame Assembly
exploded assembly
diagram of frame_*

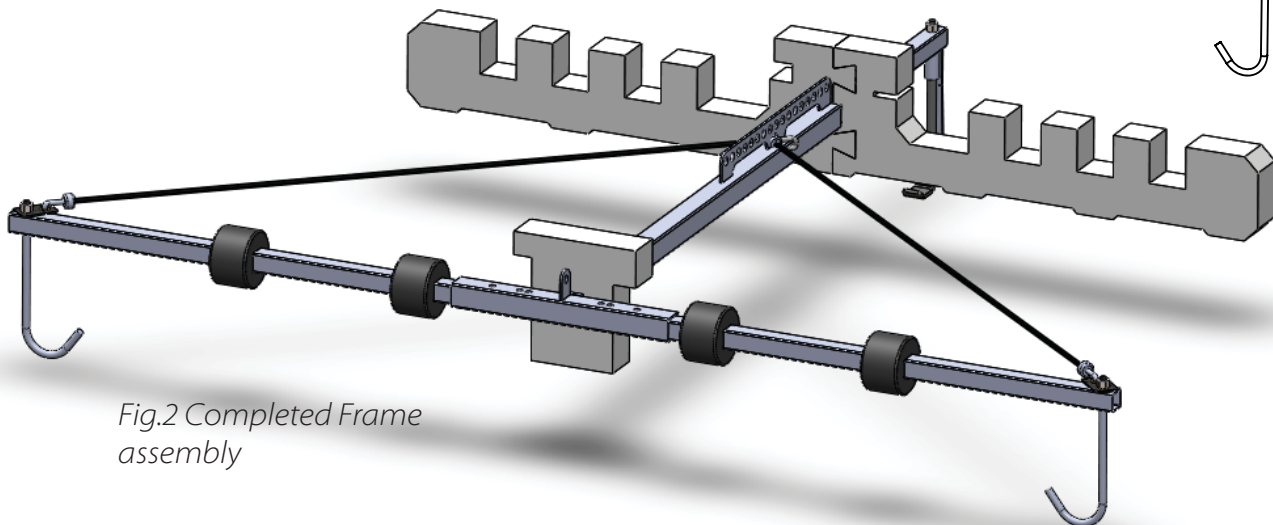

*Fig.2 Completed Frame
assembly*

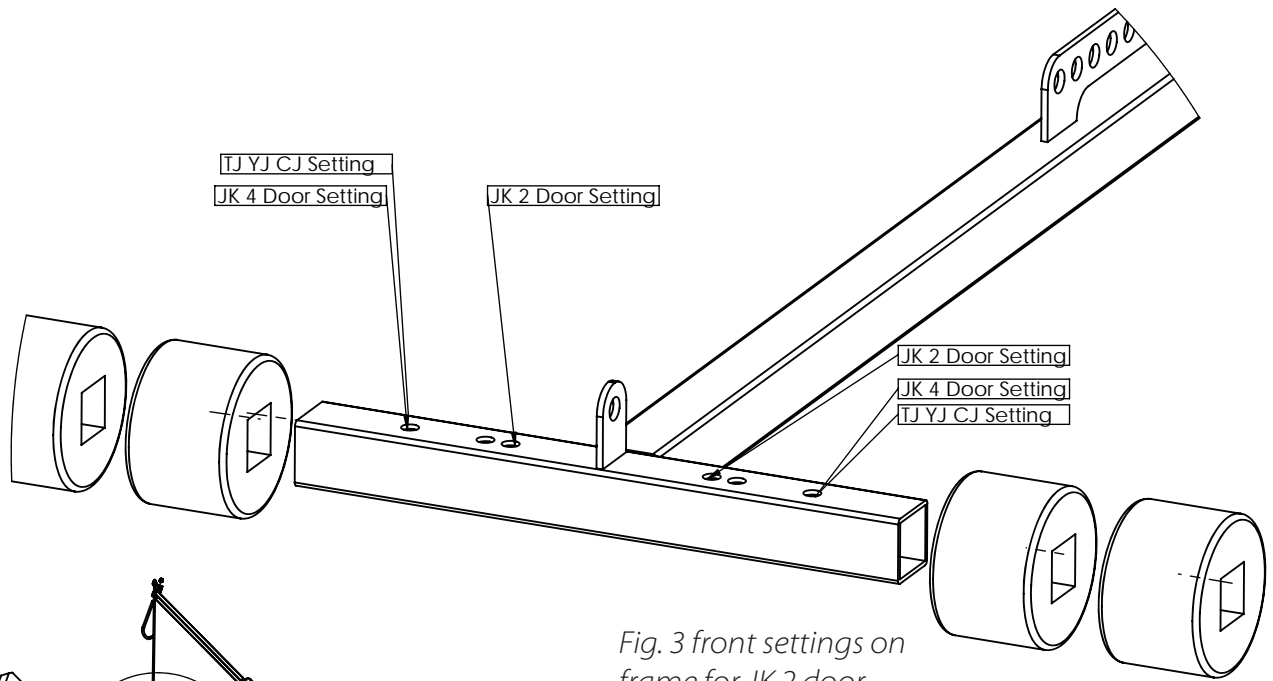

Fig. 3 front settings on frame for JK 2 door

Frame Assembly video
<https://youtu.be/QiTCFGyVK5Q>

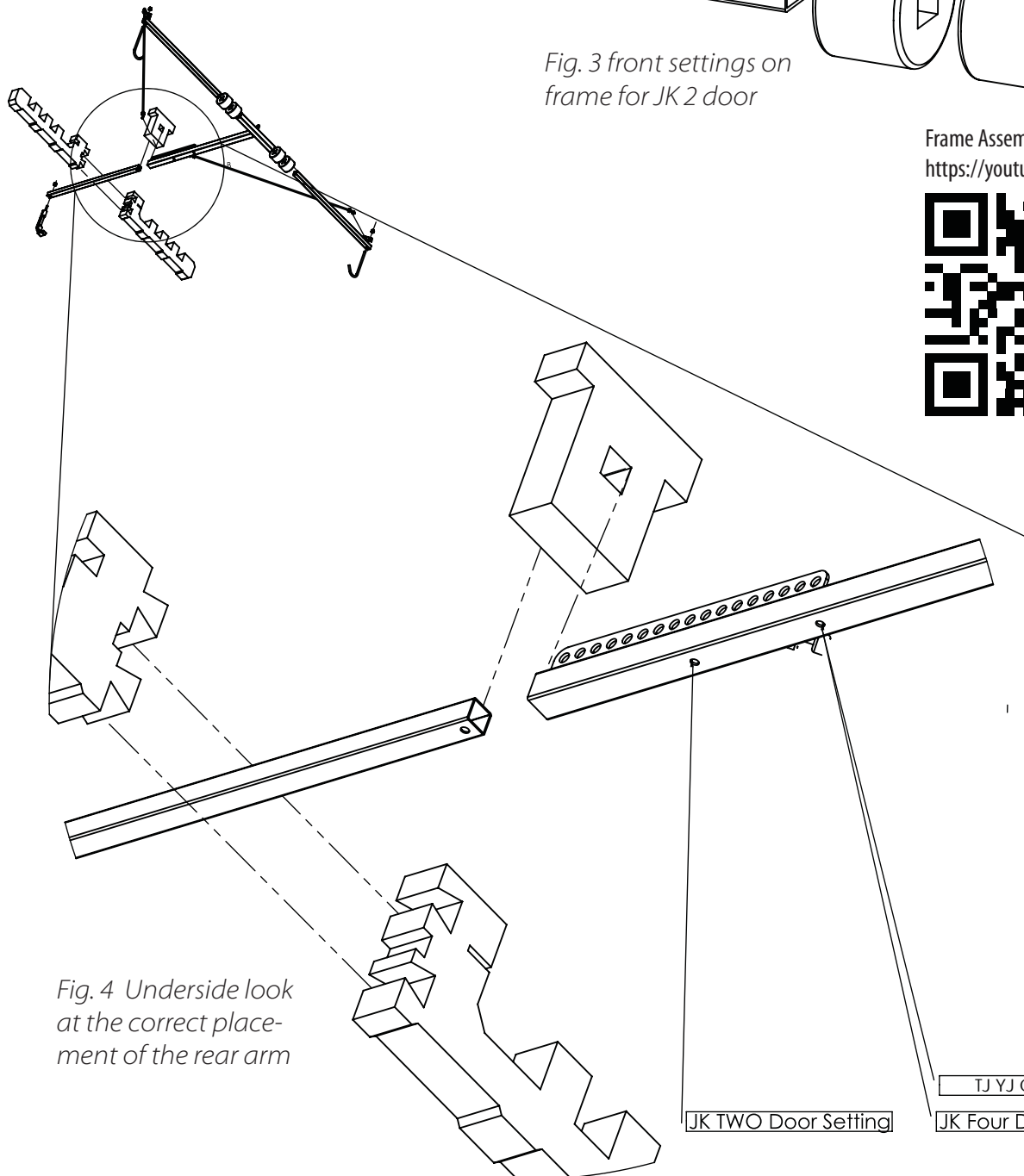

Fig. 4 Underside look at the correct placement of the rear arm

Removing Your Hardtop

Put your Hoist A Top frame on the hardtop of your Jeep, slide the rear hook between the glass of your window and the hard top and turn so it grapples the top. Make sure it is exactly centered so that your top doesn't lean to the right or left. The two J hooks in the front should grapple underneath the hard top just before the corner where the window goes. Make sure that all the torque bolts in the top, latches, windshield fluid tube, and wiring harnesses are disconnected before lifting. See our video for a helpful guide for this.



Removing the top with
Lange Hoist A Top™ system
<https://youtu.be/QiTCF-GyVK5Q?t=12m53s>

Balancing:

Lifting your hardtop is a vital step of this operation. Tested is critical. You must test the lift with at least a 100# weight.

Each Jeep hardtop has a different weight distribution.

Configuring differs with the back window open or closed, or the freedom top panel pieces on the hoist. Your top may be balanced at a different hole on the lifting blade, but here are some starting points: Four from the front is for JK Four doors with freedom top pieces on, and rear window closed. Fourteen holes from the front is where we start with the JK 2 door with freedom top pieces on the hoist and window closed. The TJ Jeep top starts 16 holes from the front (two from the rear). You may have to lift your top several times to find a balancing point. If it hangs unbalanced leaning toward the front of

your Jeep, move the pulley toward the front, and the reverse toward the rear to come back.

When removing your top your balance point may change depending on whether you have the rear window open, change the centering on the hoist frame, or leave your freedom top pieces off and will have to be rebalanced.

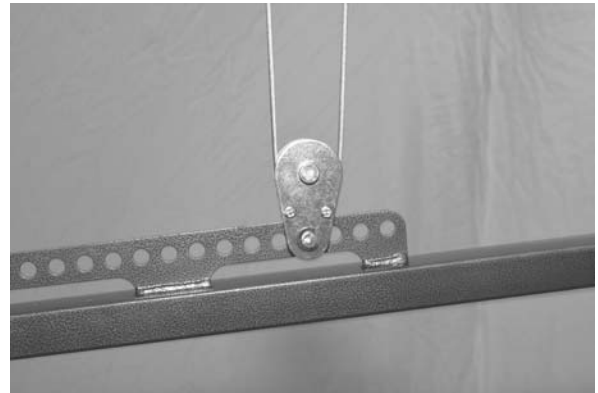

Shown here in the beginning balancing position for the JK four door with freedom pieces on.

Glossary of Terms

Cribbing: The act of cross bracing perpendicular with a piece of wood. In our case we are laying a 2x6 or wider flat across ceiling or wall joist; securing with four inch decking screws. This is an example of cribbing between wall joists on 16" centers with a 2x6. For ease of install and support we recommend cribbing all power unit installations.



Plumb-Bob: A bob of lead or other heavy material forming the weight of a plumb line. It can be as simple as a sharpie or pencil tied to a string.

Jeep Wrangler "TJ" "YJ" "CJ" and "JK" Two or Four Door: Each Jeep Wrangler has a two letter designation that describes it's run series. The TJ ran from 1997-2007 JK is designated by how many doors it has and it's run is from 2007-2019. YJ is from 1987-1996. CJ owners know exactly what I'm talking about already ;)

Lifting Blade: Hockey skate blade shaped metal fin welded in the center of the "T" and drilled with several holes.