



Power Installation Instructions



Hoistatop.com
Lange Originals
3651 S. 700 E.
Salt Lake City, UT
801-262-7322



PLEASE READ ALL INSTRUCTION BEFORE INSTALLATION

Parts List

This list may include optional items, from other Hoist-a-Top® systems, as well as a list of common parts included in all hoists. Parts are listed by part number, description, and quantity. The part number may be referenced in the instructions designated by parenthesis () for your convenience. Parts are updated periodically and may have a different color or shape..

Part Number	Description	Qt
Common Parts (All systems have these parts)		
1	Support Arms	3
2	"T" Section	1
3	Black Foam Holes	3
4	Plastic End Caps	3
5	"J" Hooks	2
6a	Rear "Smart Hook™" JK only	1
6b	Rear Hook for CJ/YJ/TJ only	1
7	Nyloc Nuts	3
9	Ceiling Pulley	2
10	Wood Screws for pulleys	9
11	Zinc Plated 3.5" screws for lumber	14

Power Unit Additional Parts

1a	110V Winch	1
2a	Large Eye-lag	1
3a	Mounting Bar	1
4a	4" Lag Screws	2
5a	Wire Clamps	8
6c	3/8" Washer	2
7a	Weighted Saftey Stop	2
8a	3/16" thimble	2

Optional Parts for JK Jeep Hoists 2007-2018

1d	Black Foam Hole	1
2d	Foam "T" Support	1
3d	Long Foam Support Arms	2
4d	Strap w/Grommets	2
5d	Bungies	2

Optional Parts for JL Jeep Hoists 2018 and Newer

6d	JL rear "Smart Hook™"	1
7d	Wing Nut	1

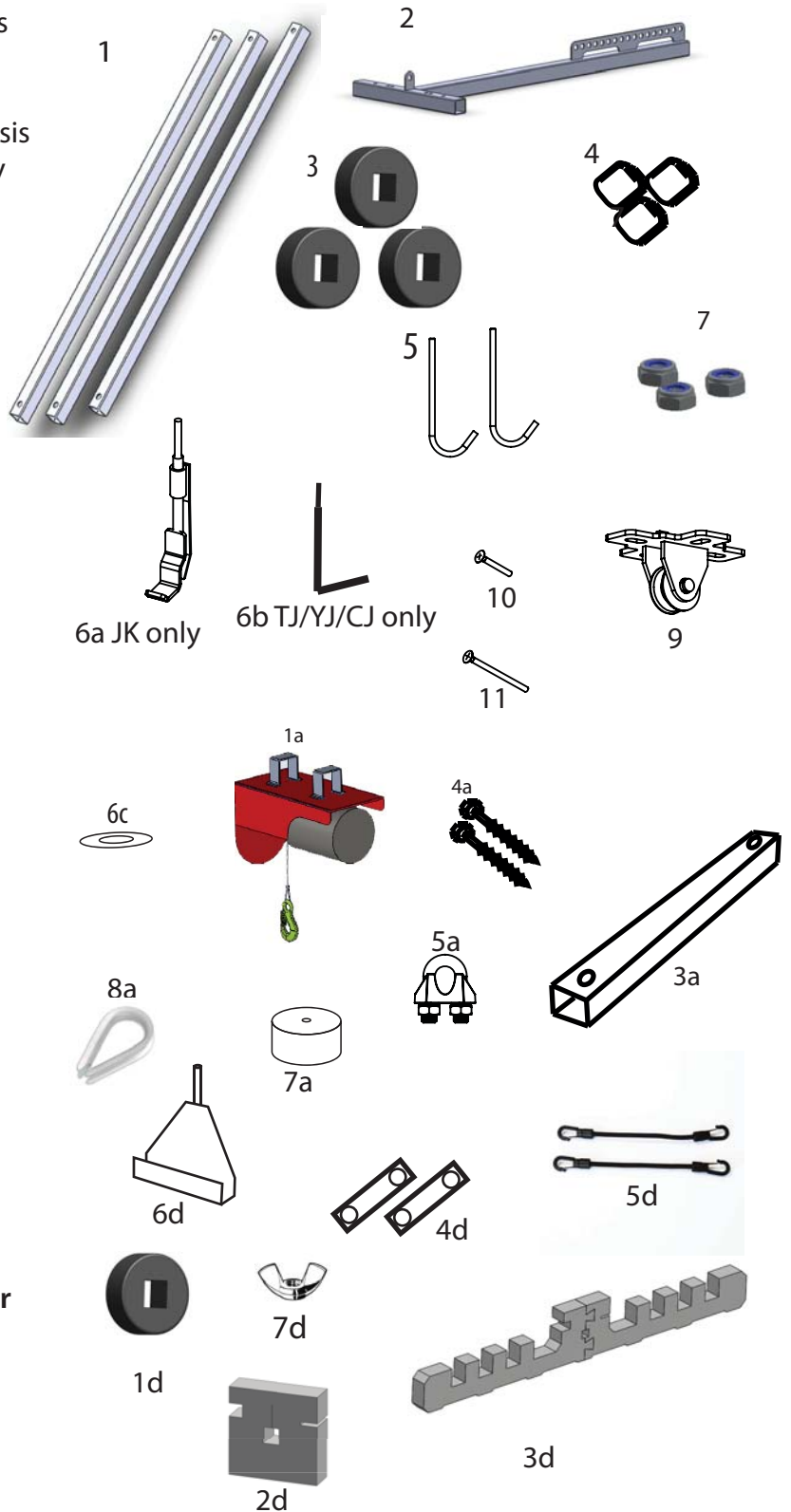



Lange Power Unit Installation Instructions

Tools needed: Safety glasses , gloves, screwdrivers, socket wrench set with driver and sockets, drill, standard drill bits, stud-finder, and chop saw/skill saw.

Installation Time: 1-3 hours depending on experience

Installation Difficulty: 3 out of 5. Person should have a basic knowledge of common household tools and be able to find a wall stud without difficulty. Specialized tools not required. Note that text underlined in the installation guide is found in a glossary of terms in the back of the guide.

Lifting Cautions

Never lift your top so it is tight against the ceiling. This puts undue stress on the top and the hoist. Keep your body, especially your hands away from edges of the top. We recommend you push or pull the top from the side and not use the bottom edge. There is a natural tendency to align the top with your fingers under the edge.

Periodically check nuts and bolts on the Hoist-a-Top® system for tightness. Also, inspect the ceiling mounting points for damage, or bent parts.

All Garages are different. Carefully read and watch the video and written instructions before installing. If you are unsure or uncomfortable with installing this product contact a structural professional. Always test this mechanism using a static and live load. Never stand, allow children, or pets under a lifted object on this mechanism. Misuse or improper installation of this product can result in serious injury or death. Follow all safety rules and regulations of tools and ladders while installing this product. Wear safety glasses, gloves, and boots while installing this product. Never walk under or allow others to either play, stand, or work under the top.

If you need help or are missing a part **DO NOT CALL YOUR DEALER. You will receive faster support though the factory 1-866-284-7428** We offer technical support Monday through Friday 9:00 AM to 4:30 PM Mountain Standard Time. Send us an inquiry via our website hoistatop.com anytime, or contact 1@langeoriginals.com. No question or problem is trivial so we'll try and help any way we can. We use these products ourselves and like them, we hope you will too. Lange Originals® is not responsible for damage or personal injury due to improper installation, custom installation that doesn't follow the instructions, or neglect.

There is an online video that is extremely helpful for this product. Most questions are answered visually by watching us do it in the video. Scanning the QR codes will open an video menu page . You can also browse to langeinstructions.com. We also have a section in the video for removing the hard top latches and wiring etc. Which can be tricky the first couple of times.

Warranty: This product has a 1 year limited warranty from the invoice date of purchase for defective parts only. Lange will repair or replace parts at their discretion. For full warranty information please see langeoriginals.com and click on warranty, and find your specific ordered part number. Valid invoice/receipt required.

Site Preparation

Determine whether to do a side wall mount, or a directly-over-hardtop ceiling mount. The largest determining factor of this is ceiling height. Garages with 7-9 ft ceiling it is recommended that a side wall installation is done. Garages over 9 ft tall it is recommended that the power unit is installed in an overhead ceiling mount configuration. If your ceiling is vaulted, or abnormal (anything other than parallel to the floor) consult a contractor/professional, you will be required to build additional supports for your power unit. Plug your power unit into a wall and test it up and down while holding the cable centered in the fair-lead before beginning installation.



*Huh? What's this thing? It's a QR code!
Scan it with your phone to get video help,
or additional instructions. Or go to:
www.langeinstructions.com*

Ceiling Mounting

Overhead mounting the power unit: To determine a suitable lifting point from the ceiling, back your Jeep in the garage to a suitable parking spot and run a plumb-bob from the center of your hardtop to the ceiling and make a mark with a pencil. Make sure you still have room to open your tailgate.

Using a stud-finder or your preferred method determine the closest stud/TJI set to your mark. Install cross bracing appropriate to your garage configuration (see Fig. b-e) Install the pulley on a separate 2x6 cross brace using the 4 provided long wood screws. Install "U" brackets on the back of the power unit using the provided bolts and lock washers that are in your power unit box. Using a 15/64" drill bit, use your mounting bar (3a) as a template to drill pilot holes into your cribbed cross brace and install one side of the mounting bar fairly loosely with the lag bolt (4a) and washer (6c). (With a helper) slide power unit onto the open side of the mounting bar.

Thread the other lag bolt(4a) with washer (6c) through the mounting bracket hole, and into the pre-drilled wood cross brace. Alternate tightening bolts until they are snug. Extend the cable to release some slack , thread pulley cable (see Fig. e) through the hole in the casing and spool through the offset pulley in the housing (see Fig. b-e). Leave the drop cable hanging down toward the floor. We will go over attaching the frame and balancing in the sections to follow.



Install one side of the mounting bar fairly loosely with the lag bolt (4a). (With a helper) slide power unit onto the open side of the mounting bar.



Scan here to access video instructions page that breaks down this section or go to:

www.langeinstructions.com

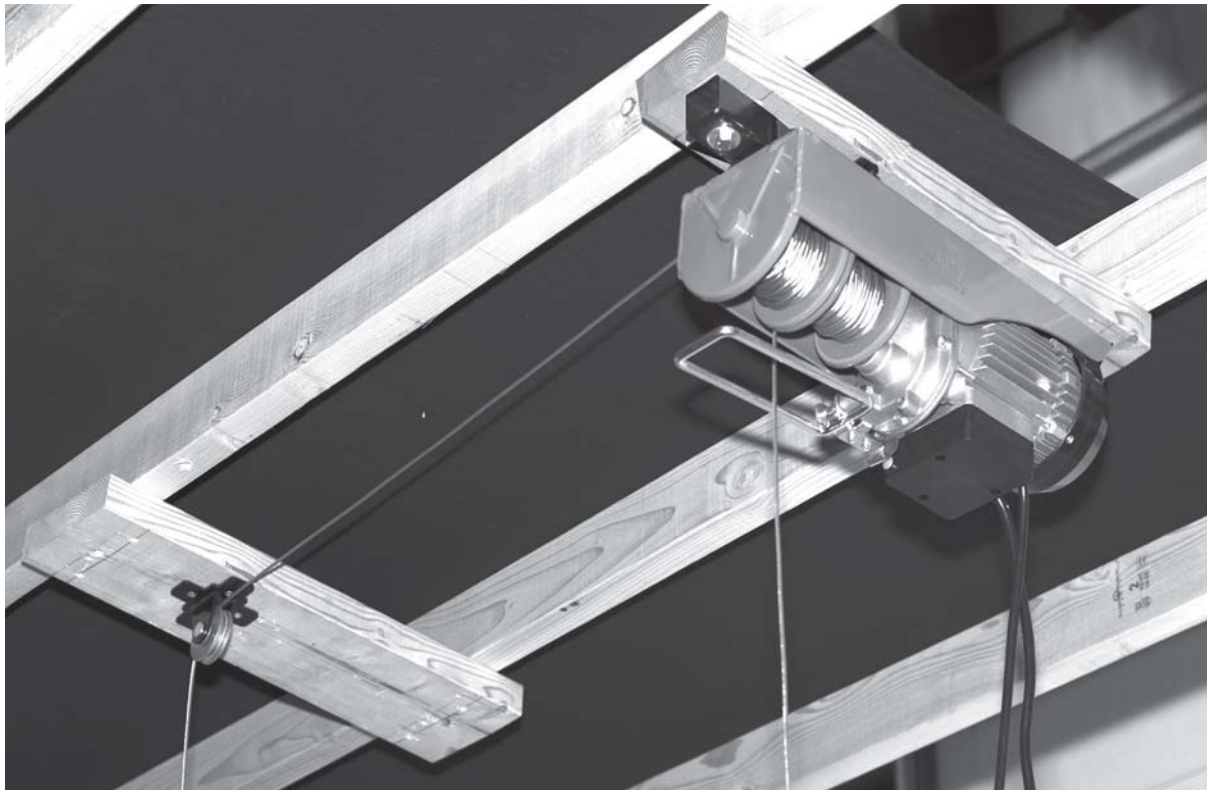

Determine if your studs run perpendicular or Parallel with your garage door. If your studs run perpendicular to (or the opposite direction as your garage door).

Center the two 2x6's between the area you marked with the plumb bob (center of your hard top measured from the ceiling down.) 2 X 6 boards are 27 inches apart.

With the mounting lag screws (4a) provided, mount the mounting bar (3a) to one 2x6 and one of the single pulleys in the center of another 2x6.

Mount the pulley offset so it lines up with the drop cable otherwise the frame will not center properly.

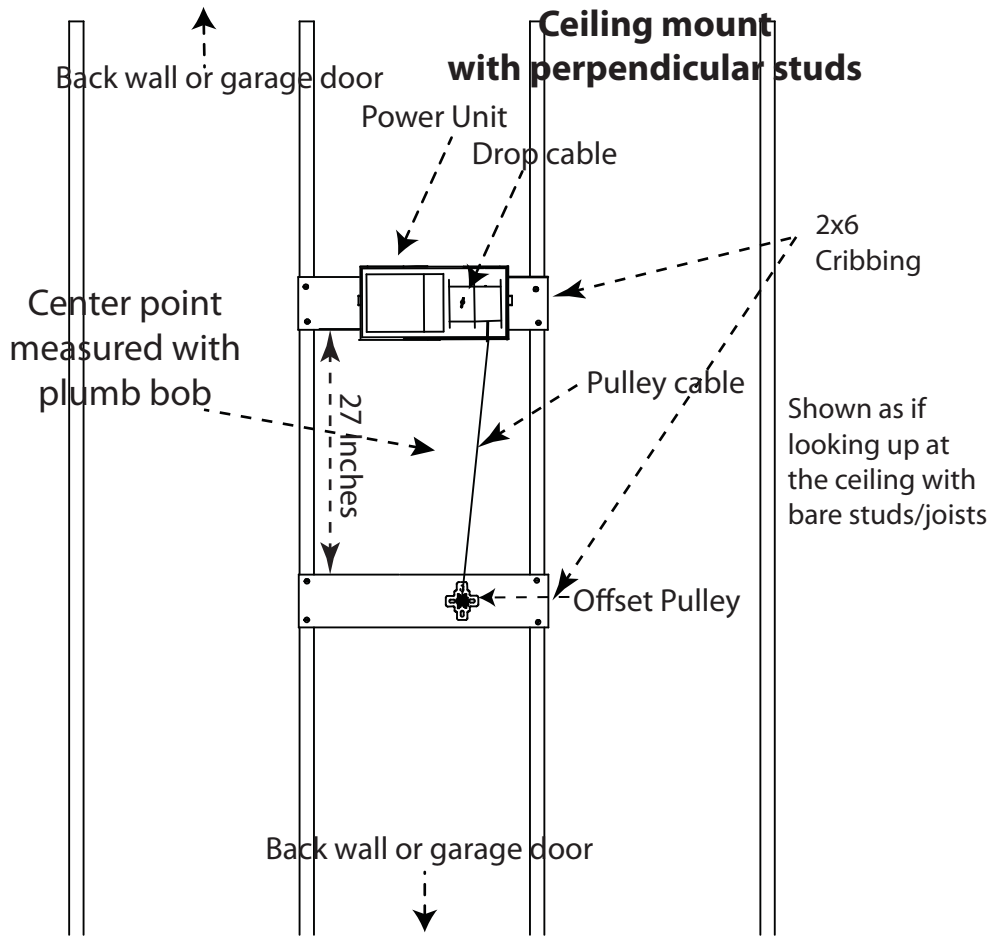

Fig. b

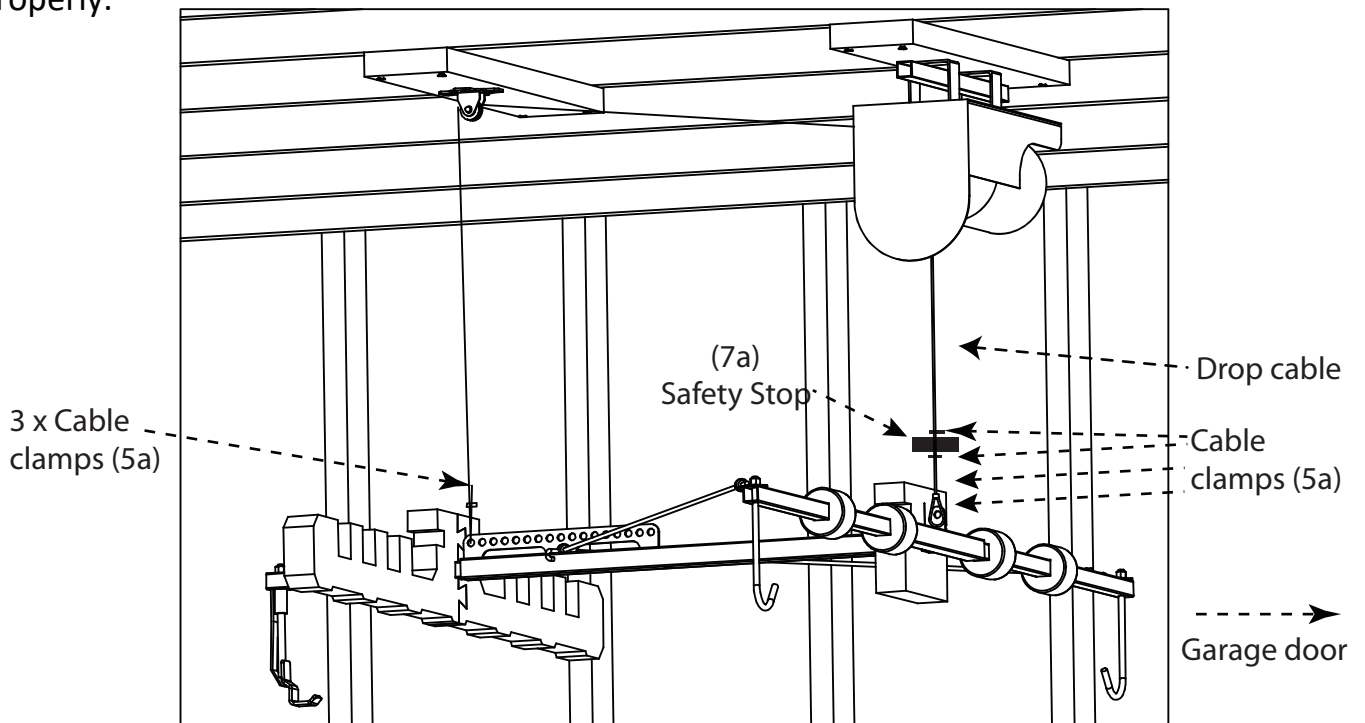

Fig. c

Parallel stud configuration

Install two cross braced 2x4's laying flat longer than the length of the gap between studs (typically 16 or 24 inch). Install mounting bracket as shown in Fig. d spanning the two 2x4's. Install the 2x6 in between two ceiling joists centering it with the drop cable. Install the pulley in the center of this 2x6 board 27 inches from the hoist casing.

Let some slack out of the spool. Thread the pulley cable through the hole in the casing then thread through the pulley. We will go over attaching to the frame in the balancing portion of the instructions.

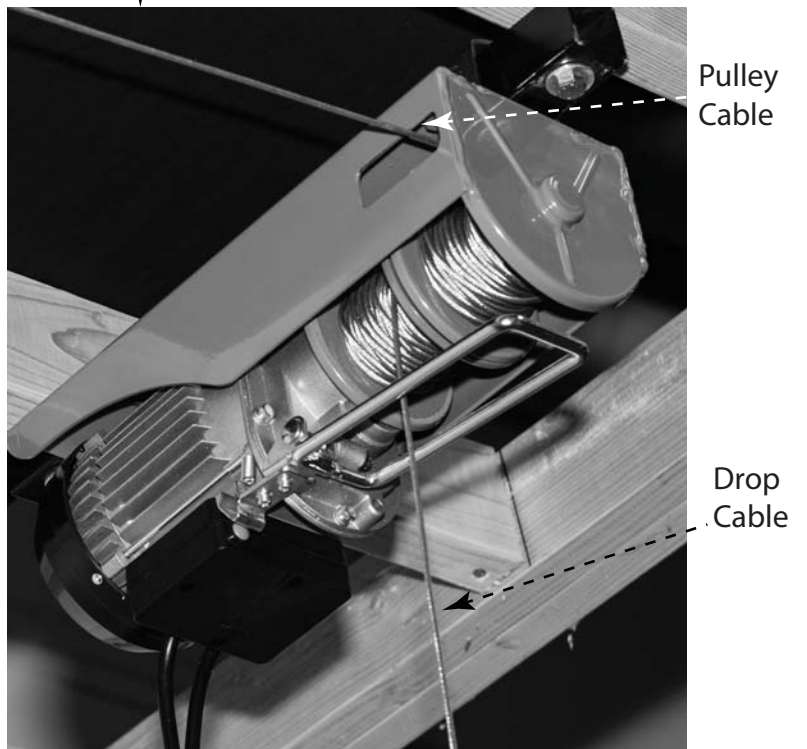
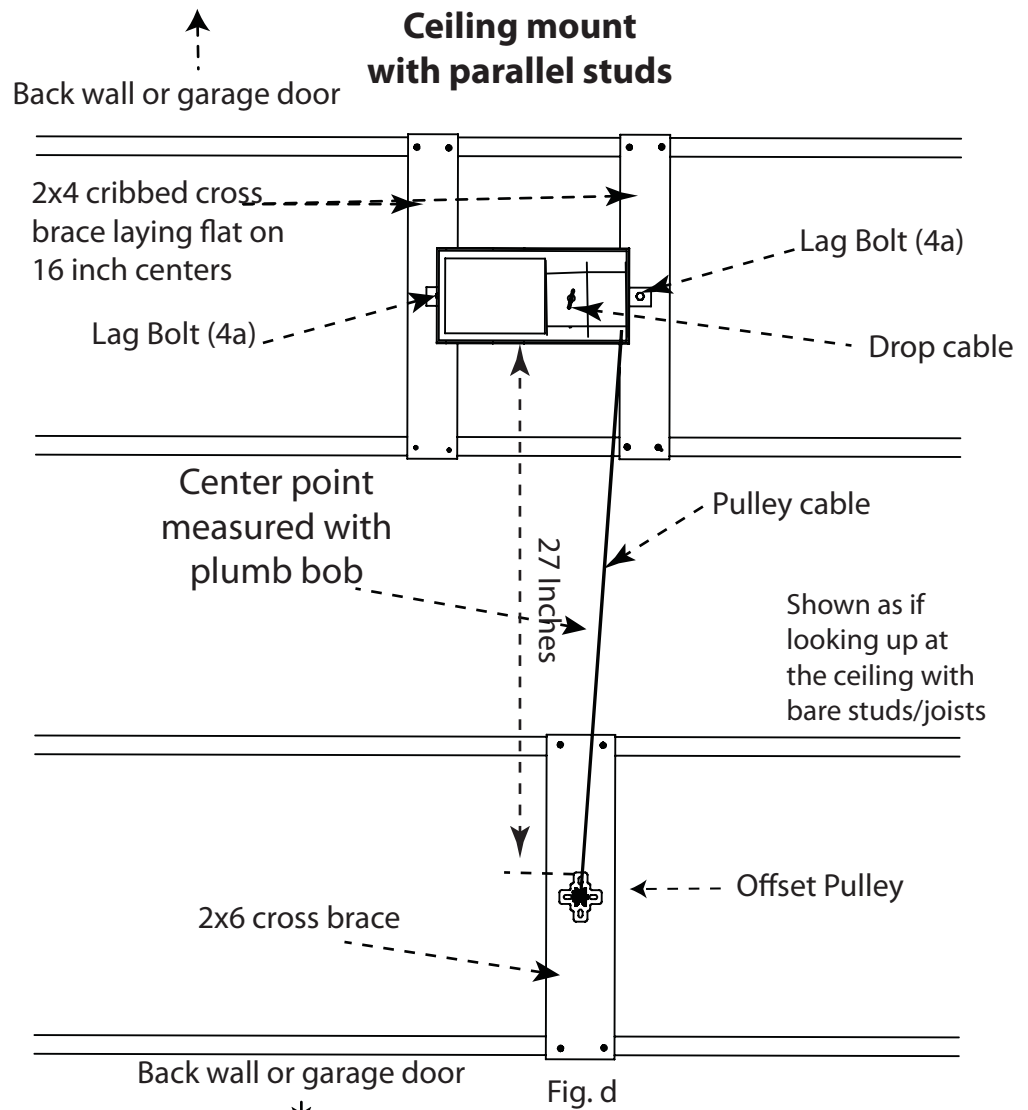

Fig. e

Sidewall/Back-wall mount:

Back your Jeep into your garage and determine a lifting point from the ceiling. Run a plumb-bob from the center of your hardtop to the ceiling and make a mark with a pencil. Draw a straight line to the wall you want your power unit on. Going back to the plumb bob mark use a stud finder or your preferred method, find which way the studs/joists are running and mark them. Reference figure j and k to install



cross braces. After we've prepared the ceiling determine the length between wall studs. Cut a 2x6 longer than the span and screw it flush with the ceiling with the provided longer screws. The mounting bar (3a), which is an 18 inch bar drilled with two holes on 16" centers, can be used as a template to mark holes to drill 15/64" pilot holes into your 2x6. If your studs are wider than 16 on center you will be required to cut a longer cross brace. Plug in and test your power unit, making sure you guide the cables out through the center of the fair-lead. Your power unit should be mounted 3 1/2 inches from the ceiling. Install one side of the power bar with the lag bolt (4a) and 3/8" washer (6c). Only install this 1 lag bolt turned a few threads in, enough to stay in the wall while you get the power unit. Install "U" brackets on the back of the power unit using the provided bolts and lock washers that are in your power unit box. With a helper slide power unit onto the open side of the mounting bar through the "U" brackets. Thread the other lag bolt/washer in the wall on the other side of the power unit. Alternate tightening bolts until they are reasonably snug.

Once the power unit is firmly attached plug it in and pull the cables out to reach the center mounting point in your garage. Note that the cable will not go up if the stop fair-lead is interfered with. Install cross braces in ceiling as depicted in figure j and k. Then thread cable through both pulleys.

Make sure the safety stop is on the longest cable and close to the power unit don't install with the cable clamps yet. Install the two pulleys on different cribbed cross braces 32 inches apart (see Fig. f) Keep in mind that the center of the pulleys is your lifting point for removing the top.



Scan here to access video instructions page that breaks down this section or go to: langeinstructions.com

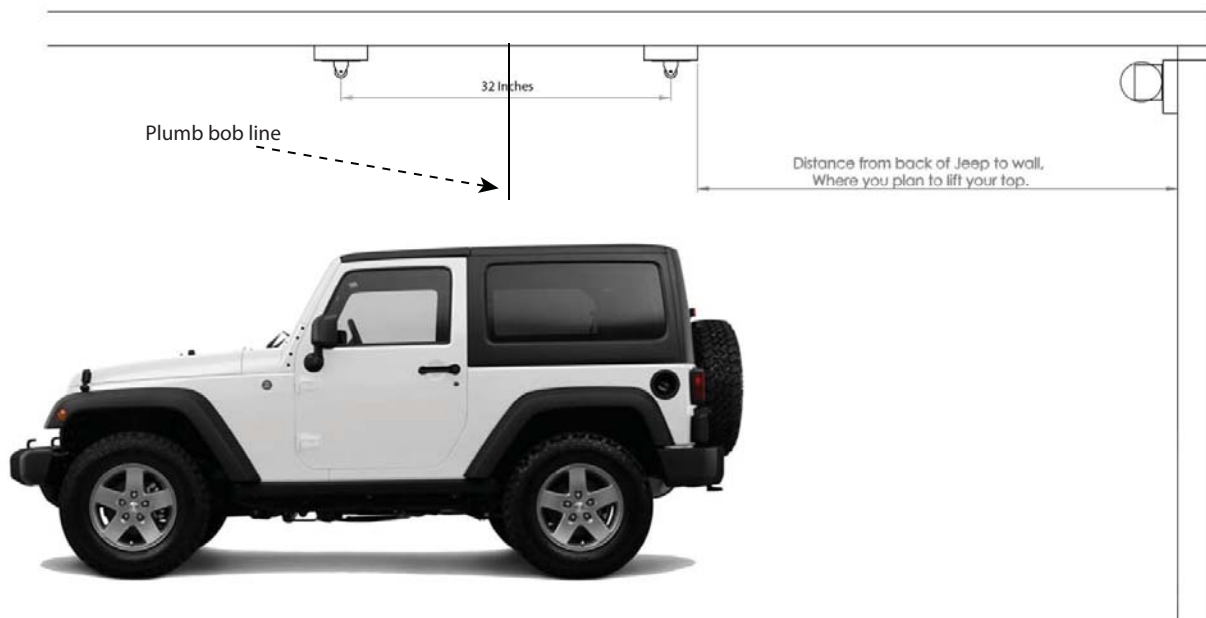

Install two cross braced 2x6's laying flat longer than the length of the gap between studs centered on the middle mark you drew with your pencil and plumb bob. The pulleys should be installed 32 inches apart centering the pulley wheels. Be sure to have a 1/2 inch offset on the two pulleys this insures that the cable will not bind. Install 2x6's with provided long screws. These figures are shown as if you were looking up at the ceiling and the studs were exposed without Sheetrock.

Perpendicular Stud Wall Mounting

Parallel stud wall mounting

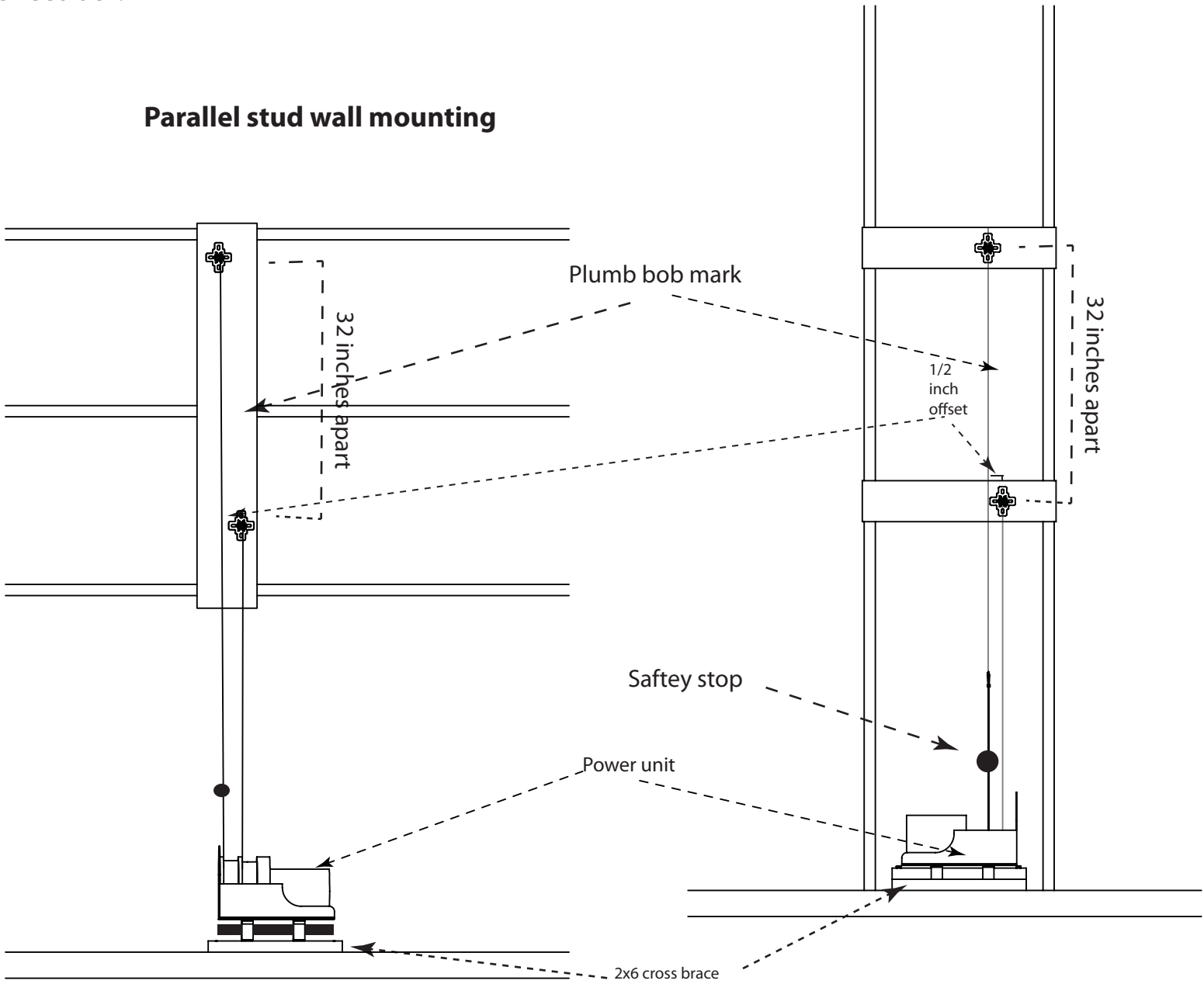

Fig. j

Fig. k

HOIST A TOP[®]

Frame Assembly

Begin frame assembly by locating the T shaped bar (2) depressing the spring buttons and sliding the front arms (1) into the T shaped bar with the spring button facing up (corresponding with the drilled holes in the T) and moving them to the appropriate holes (see frame assembly fig. 3). Slide the black round foam pieces on the arms these will protect your freedom top pieces from touching the frame and space the frame from your hardtop. The black round foam pieces should be spaced directly under your freedom top pieces when the system is used to store them. Slide the t shaped white foam piece (2d) on the base of the T over the lifting blade. There is a slit that allows you to do this. Pay close attention to the direction of the t foam in figure one, and orient it likewise. Put the rear bar (1) with spring button facing down, into the base of the T and click the spring button in the corresponding hole for your Jeep (Fig. 4). Put the J hooks in the front holes through one side of the grommet strap (4d) and thread nyloc nuts on so that 3 threads are past the nylon part of the nut. Find the rear Smart Hook™ and attach it to the base of the T shaped frame by threading it into a nyloc nut until three thread show. Do not over-tighten these hooks. Hook bungee cord to grommet strap, and any free hole in the lifting blade. Assemble long foam supports (3d) on the rear arm sliding the dovetail pieces together and the rectangle lined up with the rear arm. Insert plastic end caps. PLEASE NOTE: CJ/YJ/TJ will not have additional JK/JL parts shown. Specifically: Long foam support arms (3d) the foam t support (2d) straps with grommet, (4d) and one less black foam hole (1d).

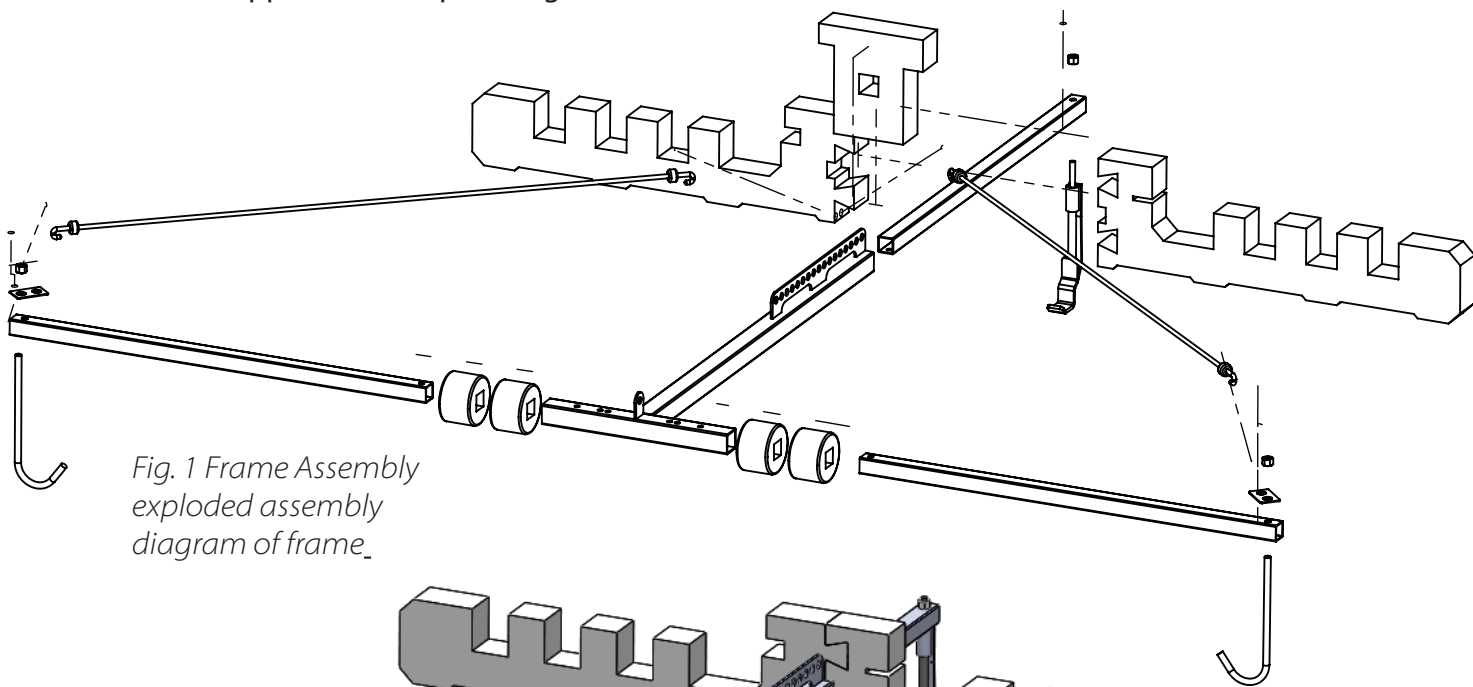

Fig. 1 Frame Assembly exploded assembly diagram of frame.

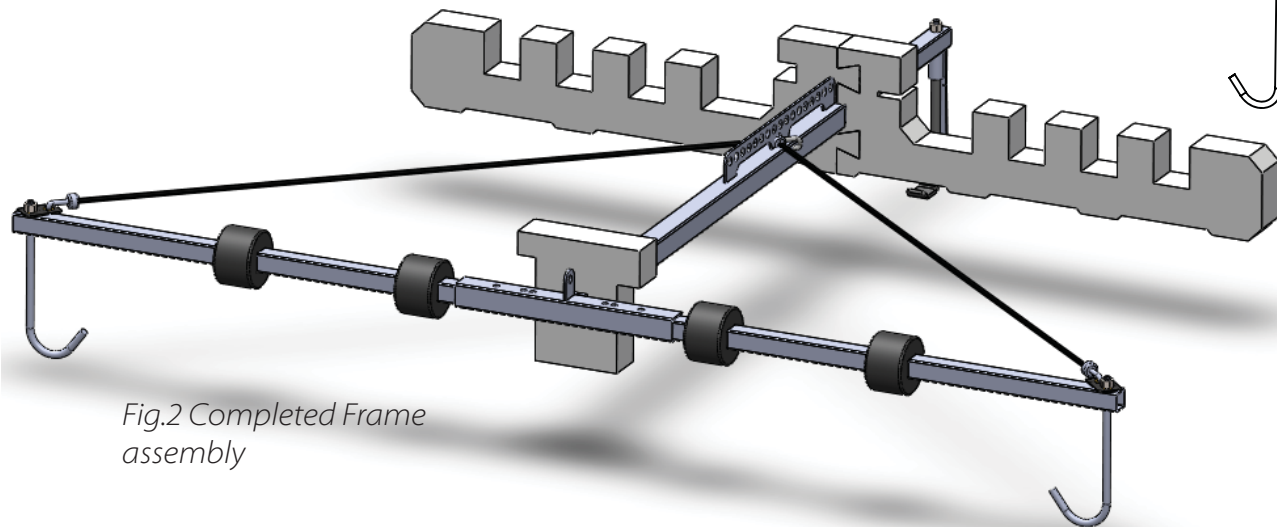

Fig.2 Completed Frame assembly

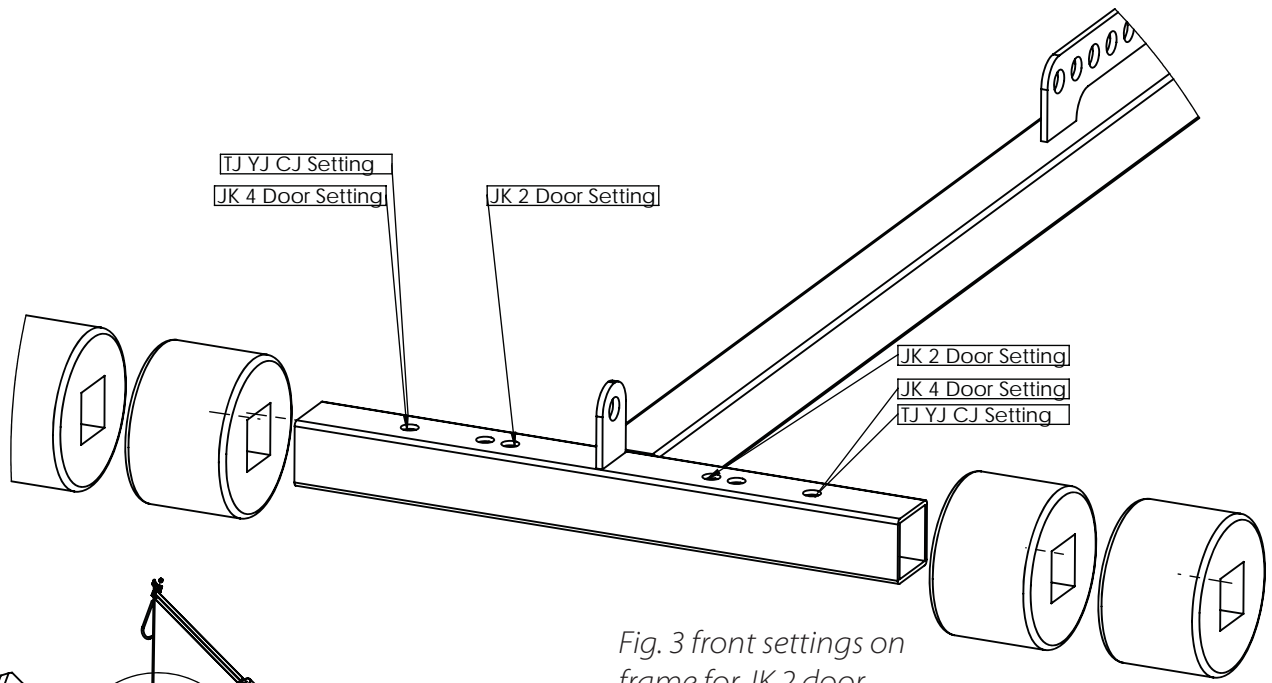

Fig. 3 front settings on frame for JK 2 door

Frame Assembly video
www.langeinstructions.com

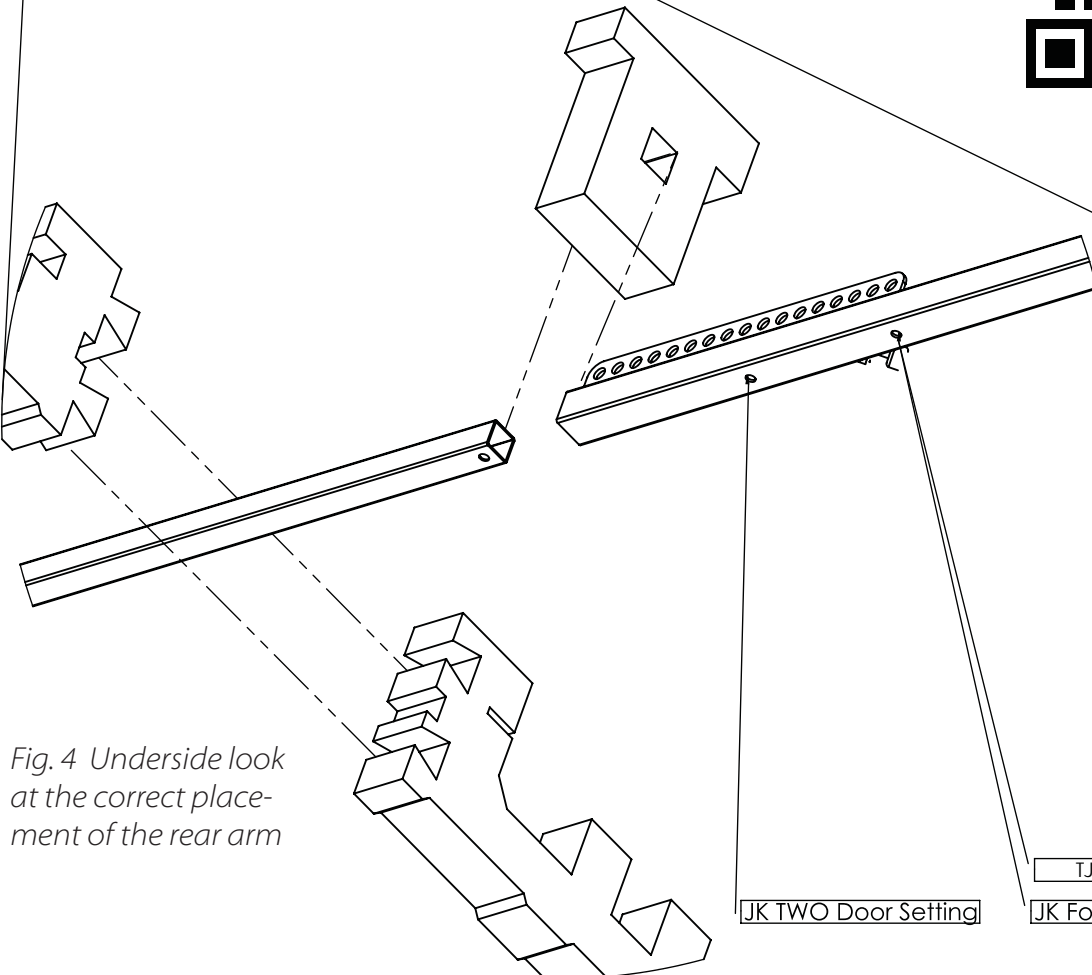
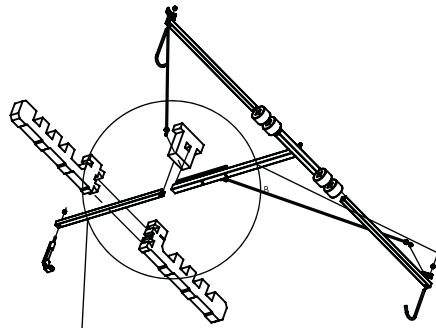

Fig. 4 Underside look at the correct placement of the rear arm

Balancing and attaching the frame

TEST YOUR INSTALL WITH WEIGHT AND INSPECT BEFORE CONTINUING!

If you have not done so put your safety stop loosely in place before this step.

With your frame assembled (see Fig. 1-4) lay it on the floor directly below the cables with the top of the "T" shape of the frame facing your garage door. If you have not done so yet let yourself out slack so we can thread the cables through the appropriate holes. (Fig. f) Insert the thimbles on the rear most hole on the lifting blade. The rear cable threads through the last hole on the lifting blade. The front cable goes on the tab on the top of the "T".



Fig. f

As shown in Fig. g wrap the cable through the hole and thimble, install cable clamps loosley at first, in order to balance the frame. With the frame flat/level on the floor pull the cable taut and tighten the cable clamps in the order shown in figure g. Be careful to not over tighten these as they will strip. If they do become stripped or are suspect do not use them, they can be inexpensively obtained at any hardware store. Inspect these and all hardware before each use.

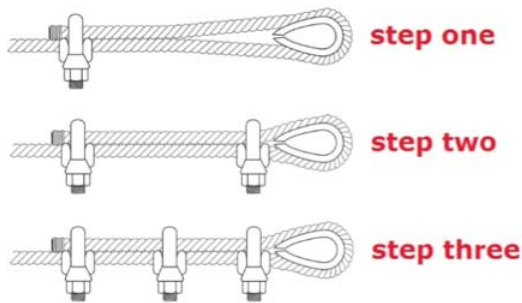

Fig. g

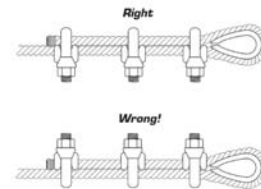

Fig. h

Now that we have our frame preliminarily balanced, it also needs to be balanced on our hardtop. If this is the first time removing your hardtop, head to our video instruction page and click on the video removing your hardtop. Put your Hoist A Top frame on the hardtop of your Jeep, slide the rear hook between the glass of your window and the hard top and turn so it grapples top. Make sure it is exactly centered so that your top doesn't lean to the right or left. The rear hook for the JK is equipped with a window placement lever that is magnetized on the top. IT SHOULD ALWAYS BE IN THE UP POSITION MAGNETIZED TO THE STEEL FRAME T WHEN MANIPULATING THE BACK WINDOW. The two J hooks in the front should grapple underneath the hard top just before the corner where the window goes. Make sure that all the torque bolts in the top, latches, windshield fluid tube, and wiring harnesses are disconnected before lifting. Have the hardtop in the configuration that you plan to store it in. Usually customers like to have the rear window closed with the roof panels on the frame. The foam supports are designed to have the white part of the freedom top pieces

facing up flipped directly on the frame and foam on the same side from where they were removed. The bungee cords hook from the grommet straps to any free hole in the lifting blade, holding them in place.

Final leveling of the hard top is achieved by loosening the cable clamps and removing some slack from the dipping side. Do this until the top is parallel to the ceiling. This is a trial and error basis and takes some fiddling, but you only have to do it once. When you are satisfied that the top is level inspect and tighten all cable clamp bolts.

Addendum for JL Jeep Hoists

This is to explain the procedure to put the rear hook on the Jeep top. Due to the unique shape, and tolerances between the glass and the top edges of the window frame the rear hook must be set in place before attaching to the frame. This is a tight fit, and some compression of the window gasket is normal.

Step 1: After assembling your frame and attaching it to the lifting mechanism. Place the assembled frame on the top of the Jeep WITHOUT the patented rear JL hook attached.

Step 2: with the window open, take the hook under the window and through the gap carefully with the threads up (fig 1.) Put the threads through the hole in the frame (fig. 2)

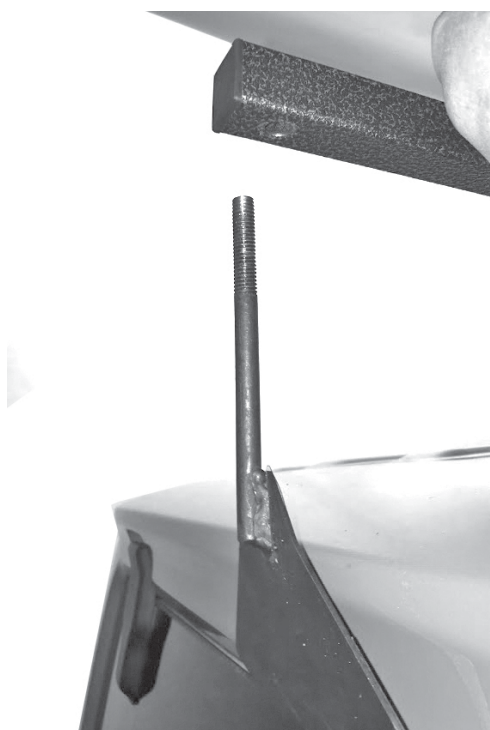

Fig. 1



Fig. 2

Step 3: Using the wing-nut thread it on the hook until you can see three to four threads out of the top of the wing-nut. Do not over tighten, this causes uneven lifting

There is also a change with the foam from the instructions. The JL foam pieces need to be put in front of the lifting blade as pictured here instead of the back of the lifting blade, also to note is the front foam is shaped slightly different than the pictured foam in the instructions. If looking at the back of the frame the small slot on the foam should be oriented on the left, or driver side.

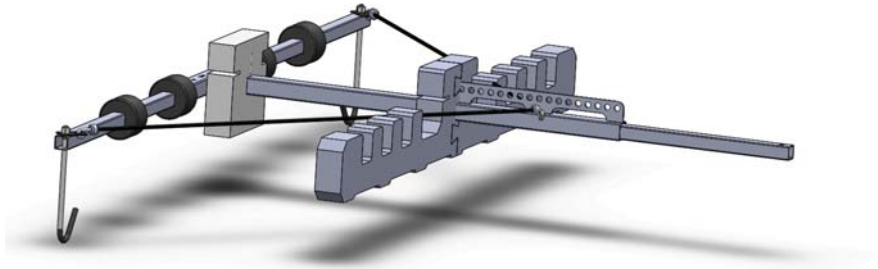

Glossary of Terms

Cribbing: The act of cross bracing perpendicular with a piece of wood. In our case we are laying a 2x6 or wider flat across ceiling or wall joist; securing with four inch decking screws. This is an example of cribbing between wall joists on 16" centers with a 2x6. For ease of install and support we recommend cribbing all power unit installations.



Plumb-Bob: A bob of lead or other heavy material forming the weight of a plumb line. It can be as simple as a sharpie or pencil tied to a string.

Jeep Wrangler "JL" "TJ" "YJ" "CJ" and "JK" Two or Four Door: Each Jeep Wrangler has a two letter designation that describes it's run series. The TJ ran from 1997-2007 JK is designated by how many doors it has and it's run is from 2007-2019. JL Jeeps are 2018 and up. YJ is from 1987-1996. CJ owners know exactly what I'm talking about already ;)

Lifting Blade: Hockey skate blade shaped metal fin welded in the center of the "T" and drilled with several holes.

The documents and instructions in this product are subject to copyright ©2016 all rights reserved. Hoist A Top, Off With Your Top, Lange Originals, are registered trademarks of Lange Originals LLC.

Hoist A Top, Hoist A Cart, Hoist A Top Simple, are protected by the following patents 009932209B2

Chrysler, Dodge, Jeep, Ram, Mopar and SRT are registered trademarks of FCA US LLC. ALFA ROMEO and FIAT are registered trademarks of FCA Group Marketing S.p.A., ©2018 FCA US LLC. All Rights Reserved.



WARNING: This product can expose you to bisphenol, a chemical known to the state of California to cause cancer or reproductive harm. For more information go to: www.p65warnings.ca.gov

Lange Originals Limited Warranty

What the Warranty Covers:

This warranty covers defects from the manufacturing process that would render the product unusable. It also covers items missing from the packaging unless the damage or loss is the result of mishandling by the shipper. This warranty supersedes all other product warranties in the instructions page.

Who is Covered?

This warranty covers the original purchaser of this device with a invoice of purchase or receipt from a valid current dealer.

How Long Does the Coverage Last?

This warranty remains in force for one year, to the original purchaser, from the date of purchase on the invoice or receipt. This warranty applies only to approved dealers of Lange's products.

What We Will do to Correct the Problem:

Lange Originals will repair or replace, at their discretion parts or the whole. Warranty does not cover 3rd party labor, or return shipping.

How do I Get Service?

To obtain warranty repairs, you must obtain authorization from Lange Originals for either a return, or replacement part. If you wish to make other arrangements for repairs/replacement, notify us on our form via our website langeoriginals.com and click on the warranty tab. We will respond in writing on how to proceed. Please do not contact your dealer, contact Lange Originals directly to avoid delays. Please note you will be asked to provide information such as dealer receipt/invoice and sometimes pictures of the item. Return shipping is not covered. We will ship any repaired or replacement items at no cost.

Normal Responsibilities of the Buyer:

Buyer is responsible for the inspection and tightening of bolts, nuts, screws, lag screws, gears, pulleys, casters, u-clamps, hooks and any other parts that require regular attention. Lubricating of some parts is necessary such as the crank type worm gear, on crank type lifting units.

This Warranty Does Not Cover:

1. Any defect caused by abuse, misuse, neglect, carelessness, or accident.
2. Loss of time, loss of use, towing charges, bus fare, car rentals, labor costs of installers, or other incidental damages of property.
3. Damage as a result of not properly following directions, or common safety practices with tools, ladders, and other instruments or tools during installation.
4. Deterioration from wear or exposure.
5. Any defect caused by alteration or modification of the home/garage.
6. Any defect which would not have occurred if instructions in the instruct manual had been followed.
7. Failure of an Chrysler product due to lack of understanding. For example if a buyer does not correctly unfasten electrical cables
8. All disputes concerning this warranty would take place in Utah courts and under Utah law.
9. Shipping damage is covered under our customer satisfaction 30 day return policy, but is not covered after this period of time.
10. Minor cosmetic issues such as paint flaws, mis-shaped foam pieces that do not affect the function of the product as determined by Lange.

Lange Originals LLC reserves the right to change this document at any time and is not limited to the terms and conditions described here. For a comprehensive warranty on your specific part number/product please visit us at www.langeoriginals.com and click on the warranties page.