



## SPEEDOMETER RING SIDE MOUNT ASSEMBLY INSTRUCTIONS

For technical support contact Joker Machine

2245 Kiowa Blvd N. Ste. 100, Lake Havasu City, AZ 86403  
PHONE: 909-596-9690, FAX: 909-596-9693  
sales@jokermachine.com, www.jokermachine.com

**IMPORTANT!** Sportster Custom and Forty-Eight models require the Harley-Davidson speedo back plate and cushioning (HD #67320-95 & 67104- 95).

Mount clamp and speedo housing on left fork

Swivel Clamp Installation skip steps 1-2.

If using the swivel clamp you do not have to lift the bike on a bike stand or remove the front wheel to lower the fork tubes.

1. Lift bike on a bike stand high enough the front wheel is off the ground.
2. Loosen upper and lower triple clamp pinch bolts.  
Slide fork tubes down far enough to place clamp on left fork tube. Slide fork tubes back into place and torque to factory spec. 30' - 35' lbs.
3. Slide fork clamp bolt through the fork clamp mount into the speedometer mount ring using a 6mm hex driver/key.
4. Remove speedo from stock bracket by removing back plate, reset switch, plug and cushioning from OEM speedometer clamp.

5. Reassemble to the Joker speedometer side mount.

**IMPORTANT!** Sportster Custom and Forty-Eight models require the Harley-Davidson speedo back plate and cushioning (HD #67320-95 & 67104- 95).

6. Using BLUE LOCTITE mount speedo side mount to fork clamp.
7. Make sure you clear the gas tank before tightening down mounting screws.
8. We like to cover the wires with a plastic bellows style loom using small tie-wraps about every 1-1/2" inches. This helps the bundle stay a smooth curve.

Try our Indicator Clamp for mounting stock indicators. No electrical work required. Part number 10-306.

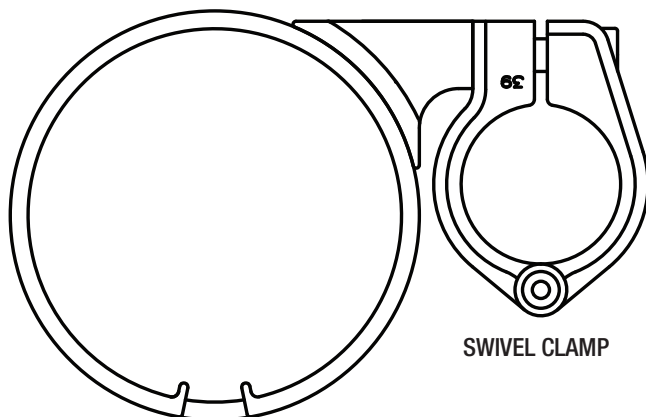

SWIVEL CLAMP

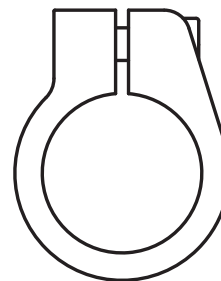

SOLID CLAMP

M8-1.25 SOCKET CAP SCREW, CAD  
NOTE: BLUE LOCTITE BEFORE FINAL INSTALLATION  
USE 6MM HEX DRIVER/KEY