



## 2013-EARLIER HD SPEEDOMETER SIDE MOUNT ASSEMBLY INSTRUCTIONS

For technical support contact Joker Machine

2245 Kiowa Blvd N. Ste. 100, Lake Havasu City, AZ 86403  
PHONE: 909-596-9690, FAX: 909-596-9693  
sales@jokermachine.com, www.jokermachine.com

**IMPORTANT!** Sportster Custom and Forty-Eight models require the Harley-Davidson speedo back plate and cushioning (HD #67320-95 & 67104-95).

### Mount clamp and speedo housing on left fork

Swivel Clamp Installation skip steps 1-3.  
If using the swivel clamp you do not have to lift the bike on a bike stand to lower the fork tube legs.

1. Lift bike on bike stand to get the front wheel off the ground.
2. Loosen upper and lower triple clamp pinch bolts. Slide fork tubes down far enough to place clamp on left fork tube. Slide fork tubes back into place and torque to factory spec. 30' - 35' lbs.
3. Slide fork clamp bolt through the fork clamp mount into the speedometer mount using a 6mm hex driver/key.
4. Remove speedo from stock bracket by removing back plate, reset switch, plug and cushioning from OEM speedometer clamp.

5. Reassemble on the Joker speedometer side mount.
6. Cut the wires at the base of the stock indicator light module.
7. Now the wires from the stock indicators must be matched up and trimmed to splice to the new indicators wires.
8. We supply the smallest butt connectors so be cautious that your crimper will work on these and not just smash them. You may choose to solder and heat shrink the wires.
9. We like to cover the wire bundle with a plastic bellows style loom using small tie-wraps about every 1-1/2" inches. This helps the bundle stay in a smooth curve.
10. Using BLUE LOCTITE mount speedo side mount to fork clamp.
11. Make sure you clear the gas tank before tightening down mounting screw.

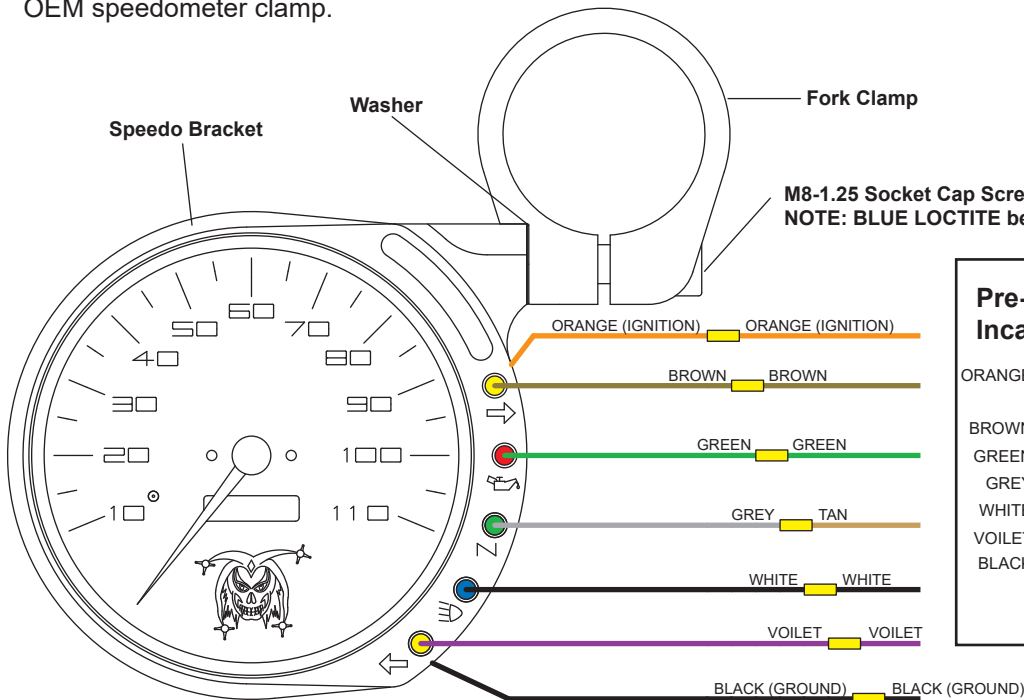

### WIRE CONNECTING NOTES:

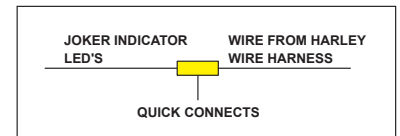

### Pre-2006 Sportster & Dyna Incandescent Lighting Wiring (10 wires)

