

Joker

MACHINE

SERRATED PASSENGER BOARD INSTRUCTIONS

For technical support contact Joker Machine

2245 Kiowa Blvd N. Ste. 100, Lake Havasu City, AZ 86403

PHONE: 909-596-9690, FAX: 909-596-9693

sales@jokermachine.com, www.jokermachine.com

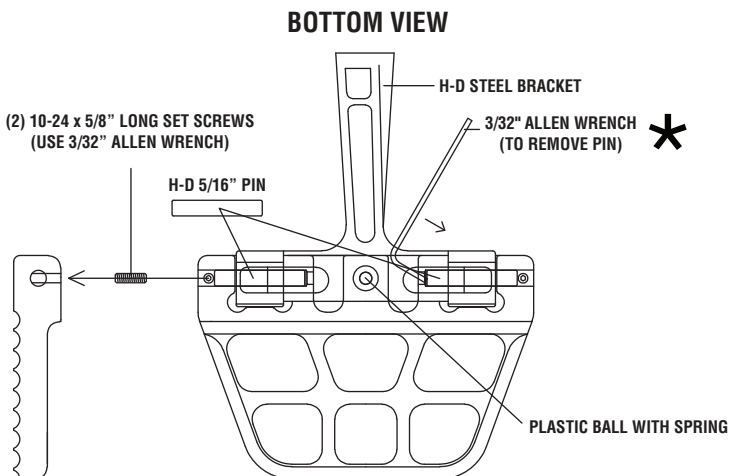

1. Remove all hardware from existing H-D cast floorboards. You will reuse the 2 pins and ball with spring on the Joker passenger boards.
2. Place plastic ball with spring into steel bracket.
3. Lay the Joker passenger boards onto the steel bracket while pushing down on the ball.
4. Now insert the H-D 5/16" pins thru the side holes until they bottom out.
5. Using a medium strength thread locker install the (2) 10-24 x 5/8" set screws with a 3/32" allen wrench in order to retain the pins in place.

* NOTE: If you want to remove these boards from the brackets for whatever reason, use the 3/32" allen wrench as shown in diagram to push the pins out.