

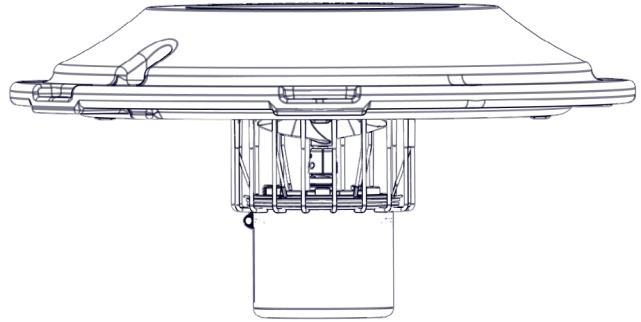

4400AF SURFACE AERATOR

OVERVIEW

- Complete package includes assembled motor unit, float, three mooring lines, and power cable.
- Operates in 19" (48cm) of water.
- Total package Listed by ETL to UL/CSA standards
- Corrosion protection for saltwater applications
- Intake near surface allows for shallow operation
- Optional lighting



MOTOR UNIT

- 1HP, 120V, single phase
- 1750 RPM
- Oil cooled, continuous duty rated
- 17mm top and bottom bearings
- Thermal overload protection
- Fully unitized heavy-duty carbon ceramic mechanical seal
- Series 300 Austenitic stainless steel can with engineering grade thermoplastic top
- Sacrificial anode
- Custom-engineered UV-resistant thermoplastic 4-blade propeller

POWER CABLE

- UL, CSA & NEC approved underwater rated cable
- 3 wire (L, N, G)
- Quick Disconnect standard on 12+ AWG cords, optional on smaller gauge cords
- Stainless steel strain relief on 12+ AWG cords
- 6' flex sleeving protection standard; optional for entire cord length

FLOAT

- UV-resistant linear low-density polyethylene
- Single-piece float
- Series 300 coated stainless steel hardware
- Three 50' braided nylon mooring ropes
- Optional coated stainless steel bottom screen

OPTIONAL CONTROL PANEL

- UL 508 Listed
- UL Type 3R/4X thermoplastic enclosure
- GFCI protection with 5ma trip level
- 24-hour mechanical aerator timer
- Photo eye for optional lighting
- 120V plug on 3' power cord

4400AF SURFACE AERATOR

HP	Voltage / Phase / Hz	Running Amps	Locked Rotor Amps	Suggested Pond Size (SA)*	Min. Depth of Operation (in.)
1	120V / 1 / 60	9.1	40	Up to 1	19"

*Surface Acreage; also consider pond shape, depth, and oxygen demand.

MODEL SPECIFICATIONS

Model	Cord Length	Cord Gauge	Number of Boxes	Shipping Weight
4400AF050	50 ft.	14/3	2	62 lbs.
4400AF100	100 ft.	12/3	3	72 lbs.
4400AF150	150 ft.	10/3	3	95 lbs.
4400AF200	200 ft.	10/3	3	107 lbs.

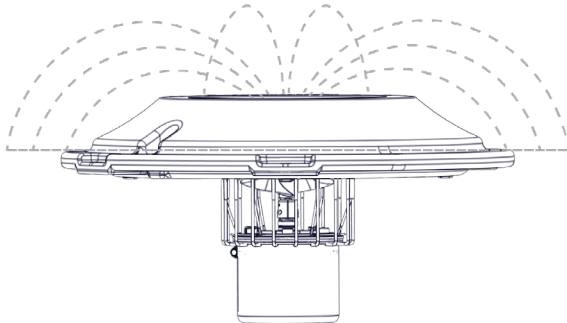

Unit + Pattern = 30" H x 50" W

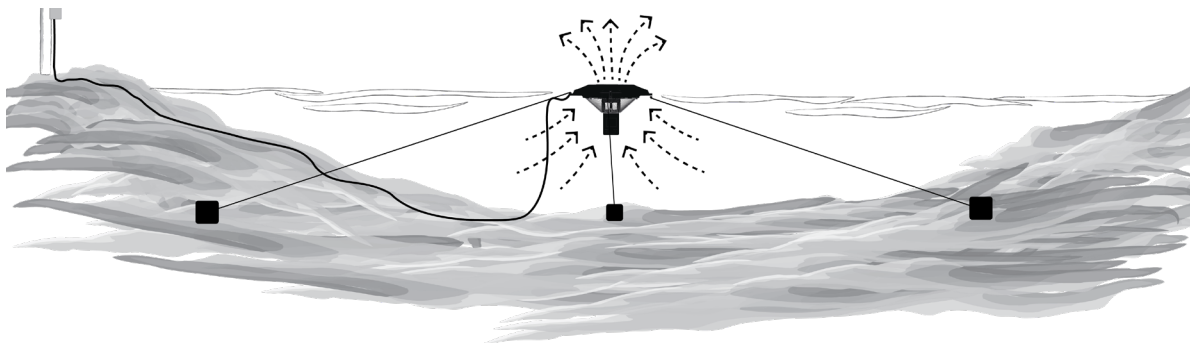
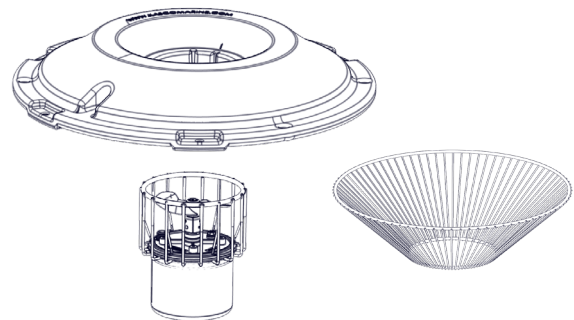

Kasco[®]

800 Deere Rd. Prescott, WI 54021

| 715.262.4488

| sales@kascomarine.com

| kascomarine.com

4400AF SURFACE AERATOR CUT SHEET



4400HAF SURFACE AERATOR

OVERVIEW

- Complete package includes assembled motor unit, float, three mooring lines, and power cable.
- Operates in 19" (48cm) of water.
- Total package Listed by ETL to UL/CSA standards
- Corrosion protection for saltwater applications
- Intake near surface allows for shallow operation
- Optional lighting

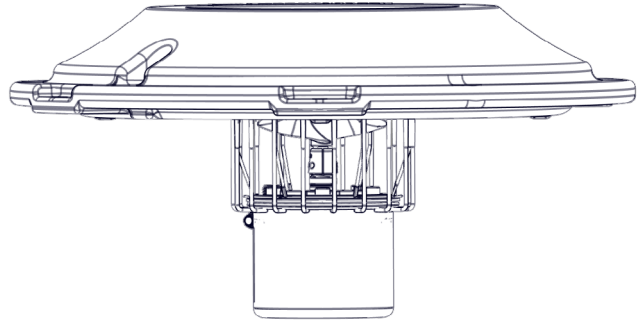

MOTOR UNIT

- 1HP, 208-240V, single phase
- 1750 RPM
- Oil cooled, continuous duty rated
- 17mm top and bottom bearings
- Thermal overload protection
- Fully unitized heavy-duty carbon ceramic mechanical seal
- Series 300 Austenitic stainless steel can with engineering grade thermoplastic top
- Sacrificial anode
- Custom-engineered UV-resistant thermoplastic 4-blade propeller

POWER CABLE

- UL, CSA & NEC approved underwater rated cable
- 3 wire (L1, L2, G)
- Quick Disconnect standard on 12+ AWG cords
- Stainless steel strain relief on 12+ AWG cords
- 6' flex sleeving protection

FLOAT

- UV-resistant linear low-density polyethylene
- Single piece float
- Series 300 coated stainless steel hardware
- Three 50' braided nylon mooring ropes
- Optional coated stainless steel bottom screen

OPTIONAL CONTROL PANEL

- UL 508 Listed
- UL Type 3R/4X thermoplastic enclosure
- 20-Amp breaker
- GFCI protection with 5ma trip level
- 24-hour mechanical aerator timer
- Surge protector
- Use C85 panel if purchasing optional lighting

Kasco[®]

4400HAF SURFACE AERATOR

HP	Voltage / Phase / Hz	Running Amps	Locked Rotor Amps	Suggested Pond Size (SA)*	Min. Depth of Operation (in.)
1	208-240V / 1 / 60	4.4	20	Up to 1	19"

*Surface Acreage; also consider pond shape, depth, and oxygen demand.

MODEL SPECIFICATIONS

Model	Cord Length	Cord Gauge	Number of Boxes	Shipping Weight
4400HAF050	50 ft.	14/3	2	66 lbs.
4400HAF100	100 ft.	14/3	2	70 lbs.
4400HAF150	150 ft.	12/3	3	85 lbs.
4400HAF200	200 ft.	12/3	3	93 lbs.
4400HAF250	250 ft.	12/3	3	99 lbs.
4400HAF300	300 ft.	12/3	3	106 lbs.
4400HAF400	400 ft.	12/3	3	120 lbs.
4400HAF500	500 ft.	10/3	3	134 lbs.

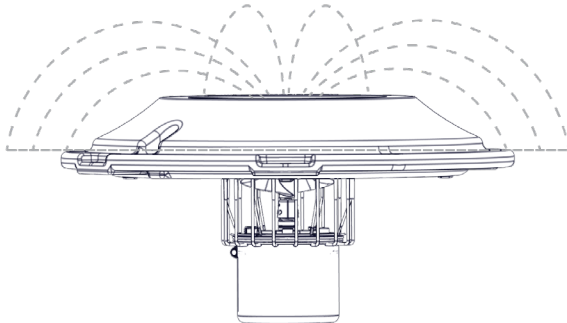

Unit + Pattern = 30" H x 50" W

