

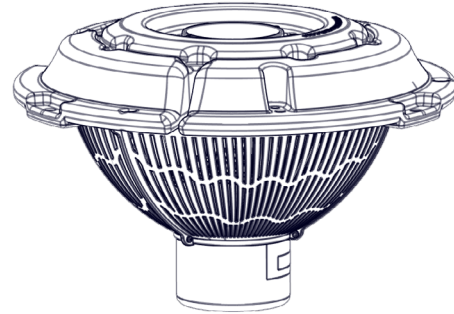

# 3400VFX FOUNTAIN

## OVERVIEW

- Complete package includes motor unit, control panel, float with screen, mooring lines, cable.
- Cable is UL, CSA & NEC rated for underwater use.
- Total package Listed by ETL to UL/CSA standards.
- Intake near surface allows for shallow operation
- Saltwater compatible
- Packaged for convenient shipping
- Optional lighting available



## Dimensions

Float diameter: 28"

Unit height with float: 18.5"

## FLOAT

- UV-resistant polyethylene
- Single-piece float
- Series 300 stainless steel hardware
- Thermoplastic protective bottom screen
- Three 50' braided nylon mooring ropes

## FOUNTAIN COMPONENTS

- Custom thermoplastic propeller
- UV-resistant thermoplastic draft tube and fountain disc
- Series 300 stainless steel hardware

## POWER CABLE

- 3 wire (L, N, G)
- Quick Disconnect standard on 12+ AWG cords (otherwise optional)
- Stainless steel strain relief on 12+ AWG cords
- 6' flex sleeving protection standard (optional for entire cord length)

## MOTOR UNIT

- 3/4HP, 120Vac operating voltage, single phase
- 1750 RPM
- Oil cooled
- Continuous duty rated
- 17mm top and bottom bearings
- Thermal overload protection
- Fully unitized heavy-duty carbon-ceramic mechanical seal
- Series 300 stainless steel can
- Engineering grade thermoplastic top
- Sacrificial anode installed on 316 stainless shaft

## CONTROL PANEL

- UL type 3R/4X thermoplastic enclosure
- Human-rated GFCI protection
- 24-hour mechanical fountain timer
- Photo eye for optional lighting
- 120V plug on 3' power cord

# 3400VFX FOUNTAIN

## OVERVIEW

HP	Voltage / Phase / Hz	Running Amps	Lock Rotor Amps	Suggested Pond Size (SA)	Min. Depth of Operation (in.)
3/4	120V / 1 / 60	7	24	Up to 1/3*	17.5"

\*Surface Acreage; also consider pond shape, depth, and oxygen demand.

## MODEL SPECIFICATIONS

Model	Cord Length (ft.)	Cord Gauge	Number of Boxes
3400VFX050	50	16/3	2
3400VFX100	100	14/3	2
3400VFX150	150	12/3	3
3400VFX200	200	12/3	3

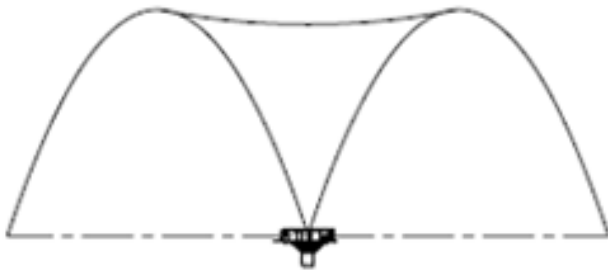

Pattern size: 5.5' H x 21' W

Easy assembly

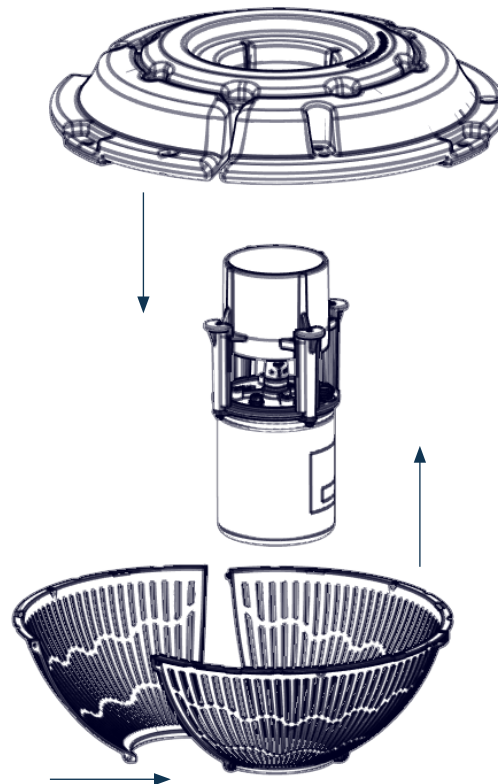

**Kasco**<sup>®</sup>



# 3400HVFX FOUNTAIN

## OVERVIEW

- Complete package includes motor unit, control panel, float with screen, mooring lines, cable.
- Cable is UL, CSA & NEC rated for underwater use.
- Total package Listed by ETL to UL/CSA standards.
- Intake near surface allows for shallow operation
- Saltwater compatible
- Packaged for convenient shipping
- Optional lighting available

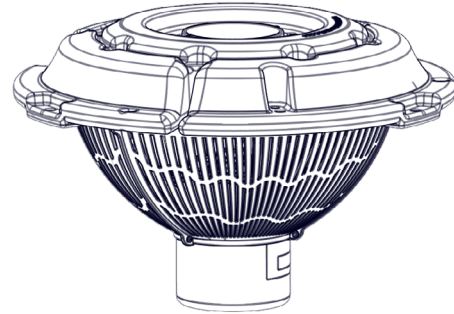

## Dimensions

Float diameter: 28"

Unit height with float: 18.5"

## FLOAT

- UV-resistant polyethylene
- Single-piece float
- Series 300 stainless steel hardware
- Thermoplastic protective bottom screen
- Three 50' braided nylon mooring ropes

## FOUNTAIN COMPONENTS

- Custom thermoplastic propeller
- UV-resistant thermoplastic draft tube and fountain disc
- Series 300 stainless steel hardware

## POWER CABLE

- 3 wire (L1, L2, G)
- Quick Disconnect standard on 12+ AWG cords (otherwise optional)
- Stainless steel strain relief on 12+ AWG cords
- 6' flex sleeving protection standard (optional for entire cord length)

## MOTOR UNIT

- 3/4HP, 208-240Vac operating voltage range, single phase
- 1750 RPM
- Oil cooled
- Continuous duty rated
- 17mm top and bottom bearings
- Thermal overload protection
- Fully unitized heavy-duty carbon-ceramic mechanical seal
- Series 300 stainless steel can
- Engineering grade thermoplastic top
- Sacrificial anode installed on 316 stainless shaft

## CONTROL PANEL

- UL 508 Listed
- UL type 3R/4X thermoplastic enclosure
- 20 amp breaker
- Human-rated GFCI protection
- Surge protector
- 24-hour mechanical timers (fountain & lights)
- Terminal block wiring
- 4-wire power required (L1, L2, N, G)

# 3400HVFX FOUNTAIN

## OVERVIEW

HP	Voltage / Phase / Hz	Running Amps	Lock Rotor Amps	Suggested Pond Size (SA)	Min. Depth of Operation (in.)
3/4	208-240V / 1 / 60	4	12	Up to 1/3*	17.5"

\*Surface Acreage; also consider pond shape, depth, and oxygen demand.

## MODEL SPECIFICATIONS

Model	Cord Length (ft.)	Cord Gauge	Number of Boxes
3400HVFX050	50	14/3	3
3400HVFX100	100	14/3	3
3400HVFX150	150	12/3	4
3400HVFX200	200	12/3	4
3400HVFX250	250	12/3	4
3400HVFX300	300	12/3	4
3400HVFX400	400	12/3	4
3400HVFX500	500	12/3	4

\*500' and longer cords available by custom order only.

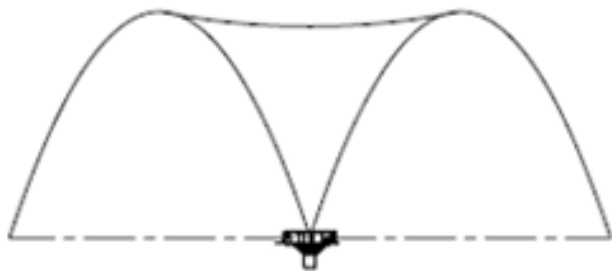

Pattern size: 5.5' H x 21' W

Easy assembly

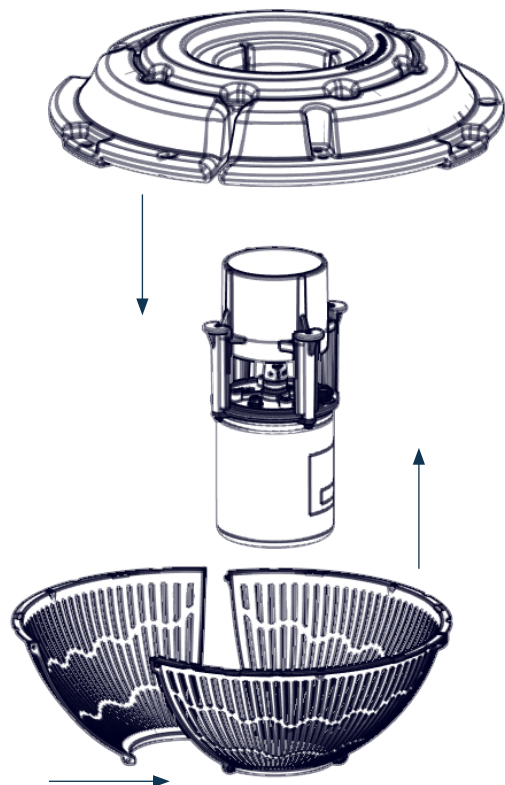

**Kasco**<sup>®</sup>

800 Deere Rd. Prescott, WI 54021

| 715.262.4488

| sales@kascomarine.com

| kascomarine.com

3400HVFX FOUNTAIN CUT SHEET