

Shallow Water Stand | Assembly Instructions

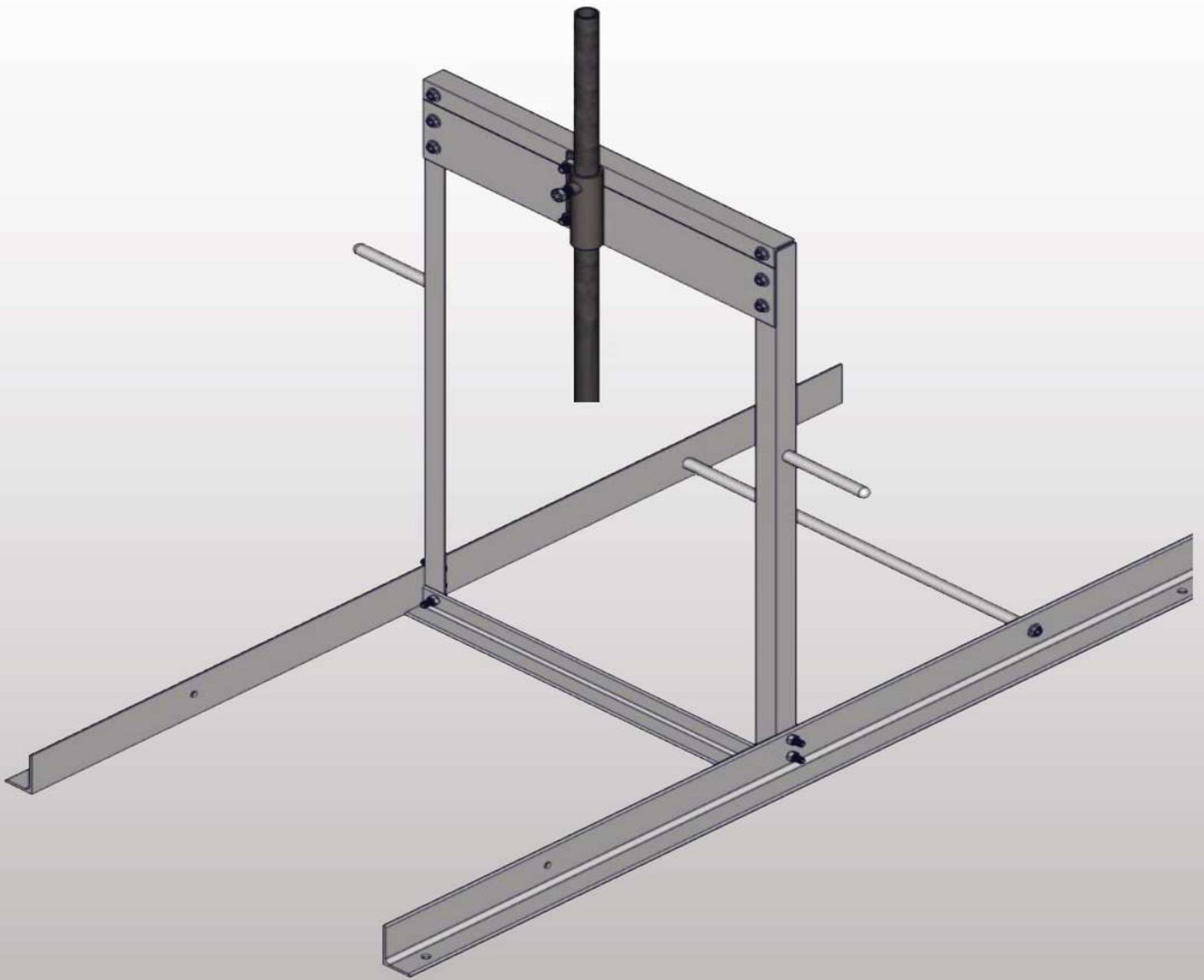

Parts

STAND PIECES

QTY	DESCRIPTION
A 2	Foot (angle): 2" x 3" x 60"
B 1	Left Vertical Bar (angle): 1 1/2" x 1 1/2" x 40"
C 1	Right Vertical Bar (angle): 1 1/2" x 1 1/2" x 40"
D 1	Bottom Horizontal Bar (angle): 1 1/2" x 1 1/2" x 26"
E 1	Support Bar: 0.75" diameter; 26"
F 1	Horizontal Brace
G 2	Handle
H 1	Bail
J 1	Pipe: 1" diameter; 26 1/2"

HARDWARE

QTY	DESCRIPTION
1	1/2-13 x 1 1/4" Bolt
1	3/8-16 x 2 1/4" Bolt
16	3/8-16 x 1" Bolt
13	3/8" Nut
16	3/8" Washer



Horizontal Brace comes preassembled to the Pipe Holder using:

QTY	Description
3	1/2-13 X 1 1/4" Bolts
3	1/2" Washers
3	1/2" Lockwasher
3	1/2" Nut

*drawings not to scale

*(2) 9/16 wrenches for assembly (not included)

Frame



Step One:

Attach the Bottom Horizontal Bar (D) to the Left Vertical Bar (B) and Right Vertical Bar (C) with $\frac{3}{8}$ "-16 x 1" bolts, washers & nuts.

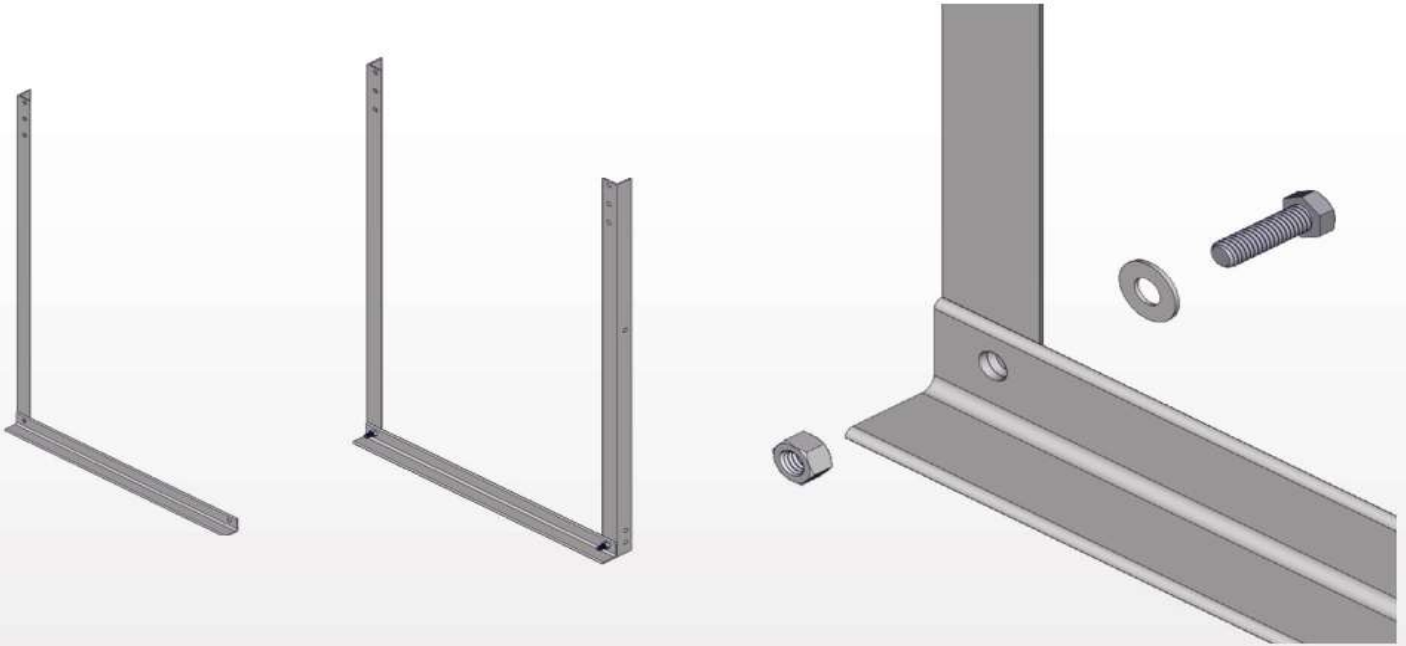

Step Two:

Attach Foot (A) with $\frac{3}{8}$ "-16 x 1" bolts, washers & nuts.

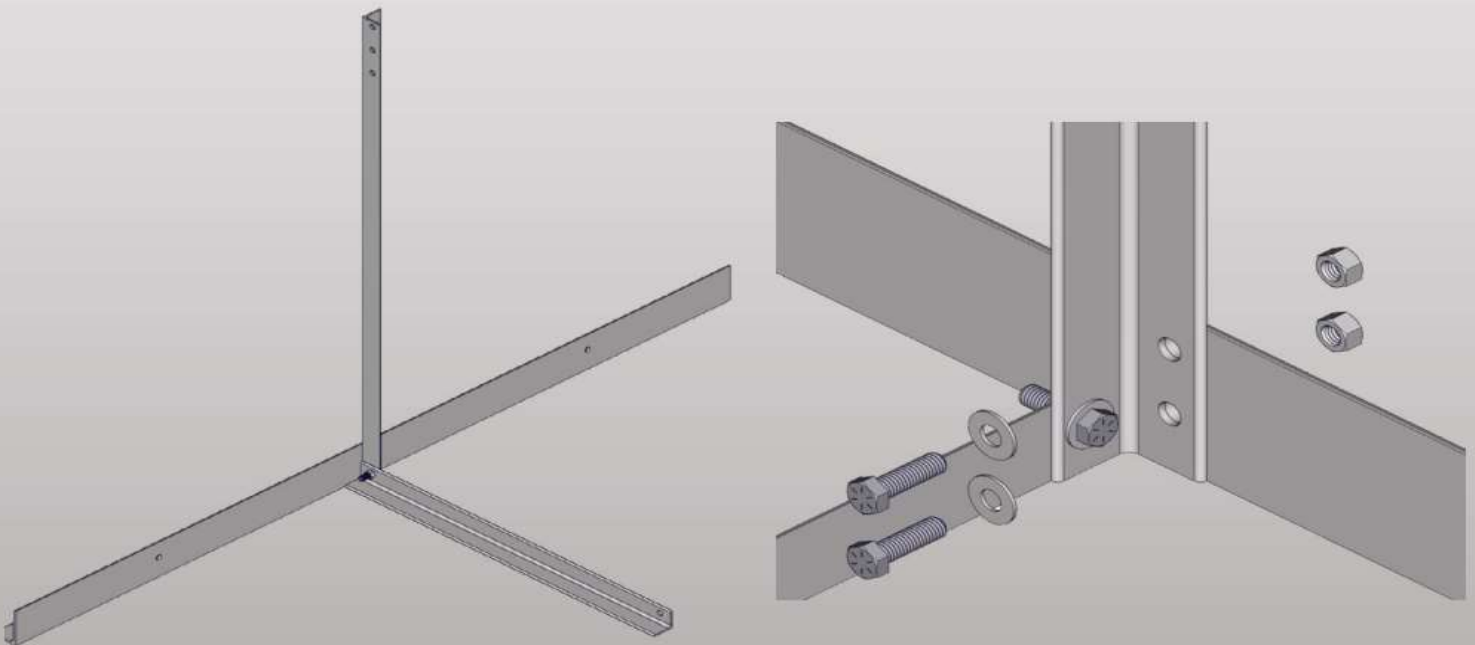

Step Three:

Attach Foot (A) with $\frac{3}{8}$ "-16 x 1" bolts, washers & nuts.

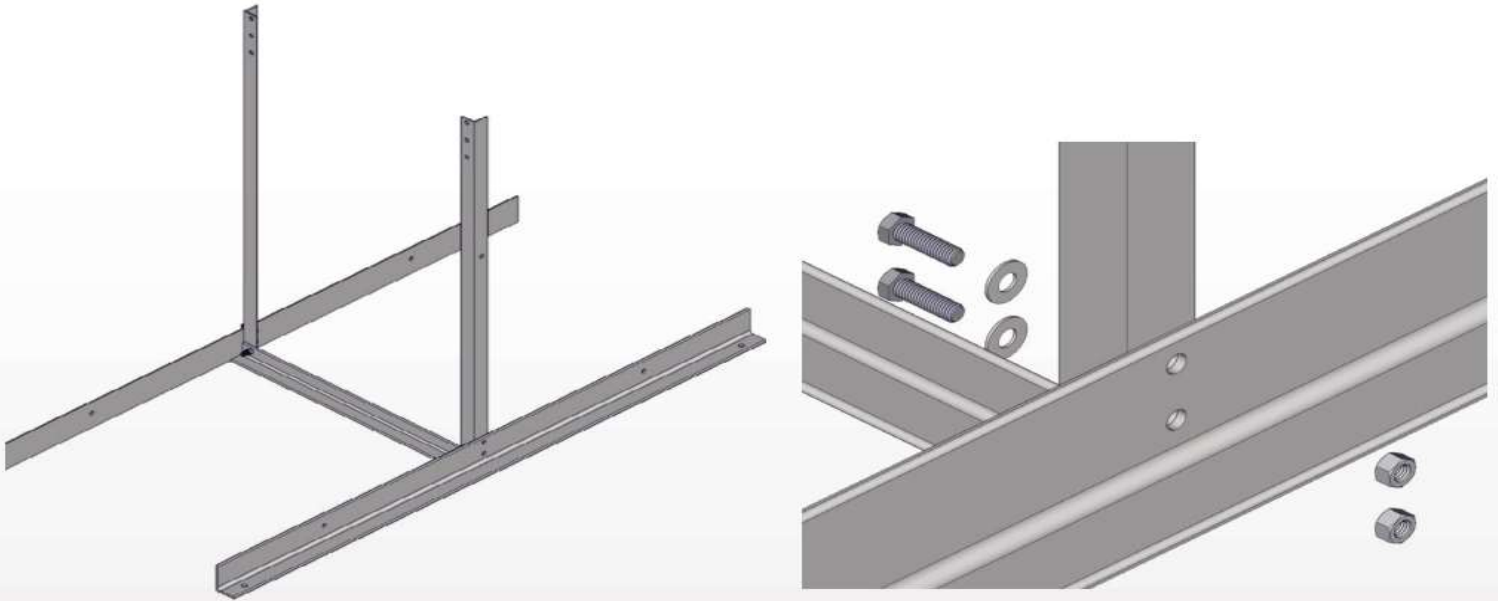

Step Four:

Attach Support Bar (E) to the Left and Right Feet with $\frac{3}{8}$ "-16 x 1" bolts & washers.

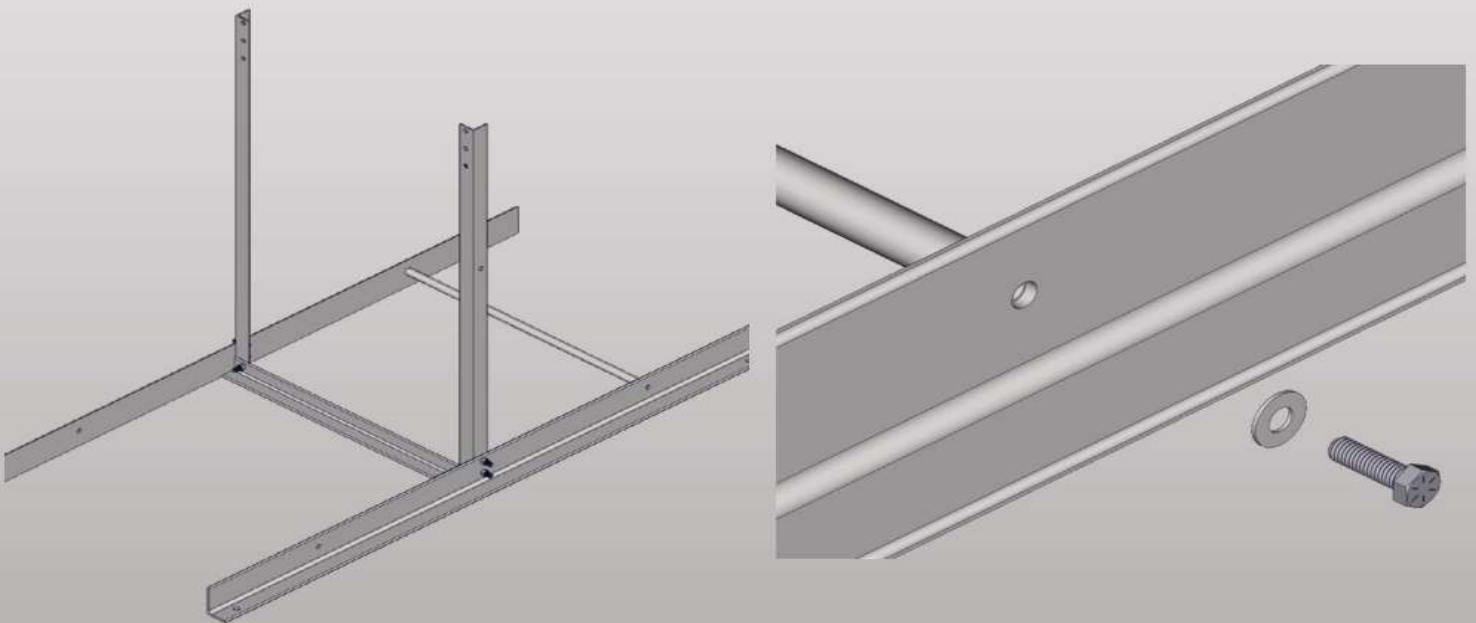

Step Five:

Attach Horizontal Brace (F) to the Left Vertical Bar (B) and Right Vertical Bar (C) with $\frac{3}{8}$ "-16 x 1" bolts, washers & nuts.

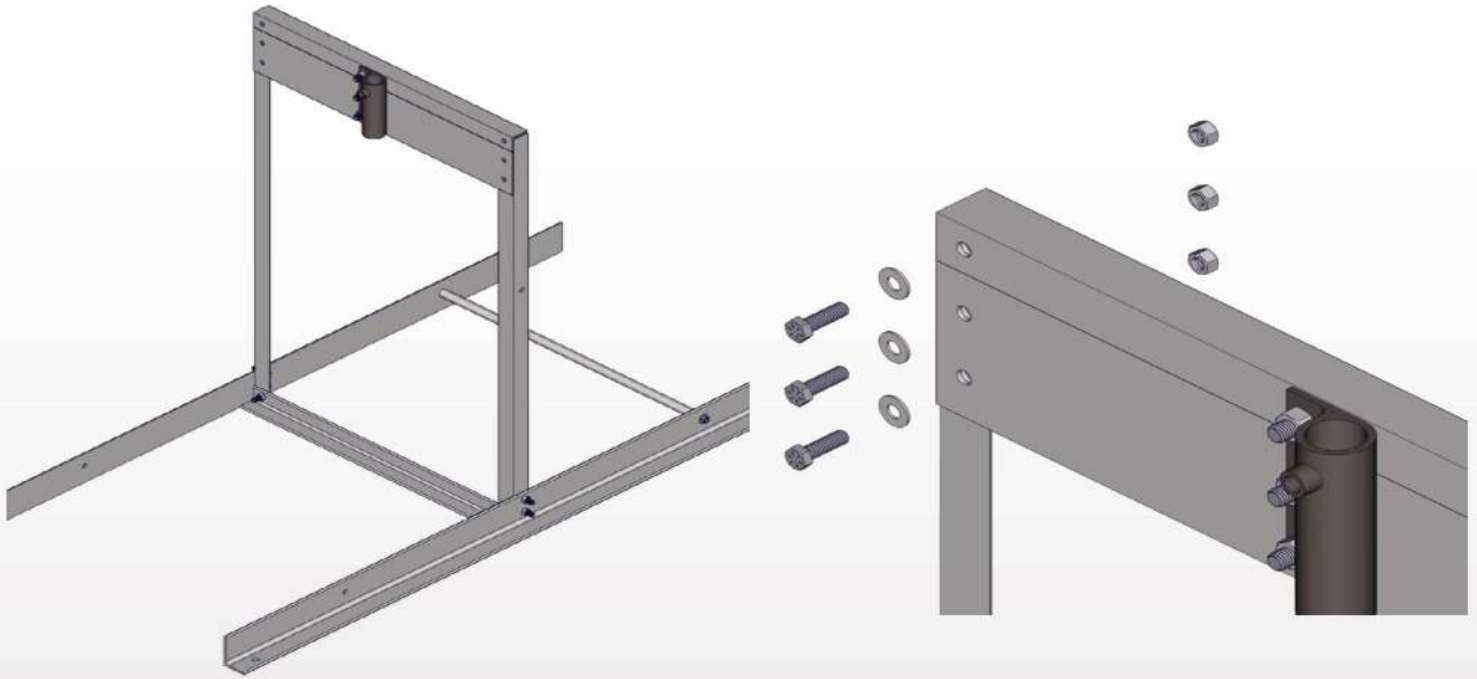

Step Six:

Attach Handles (G) to the Left and Right Vertical Bars with $\frac{3}{8}$ "-16 x 1" bolts & washers.

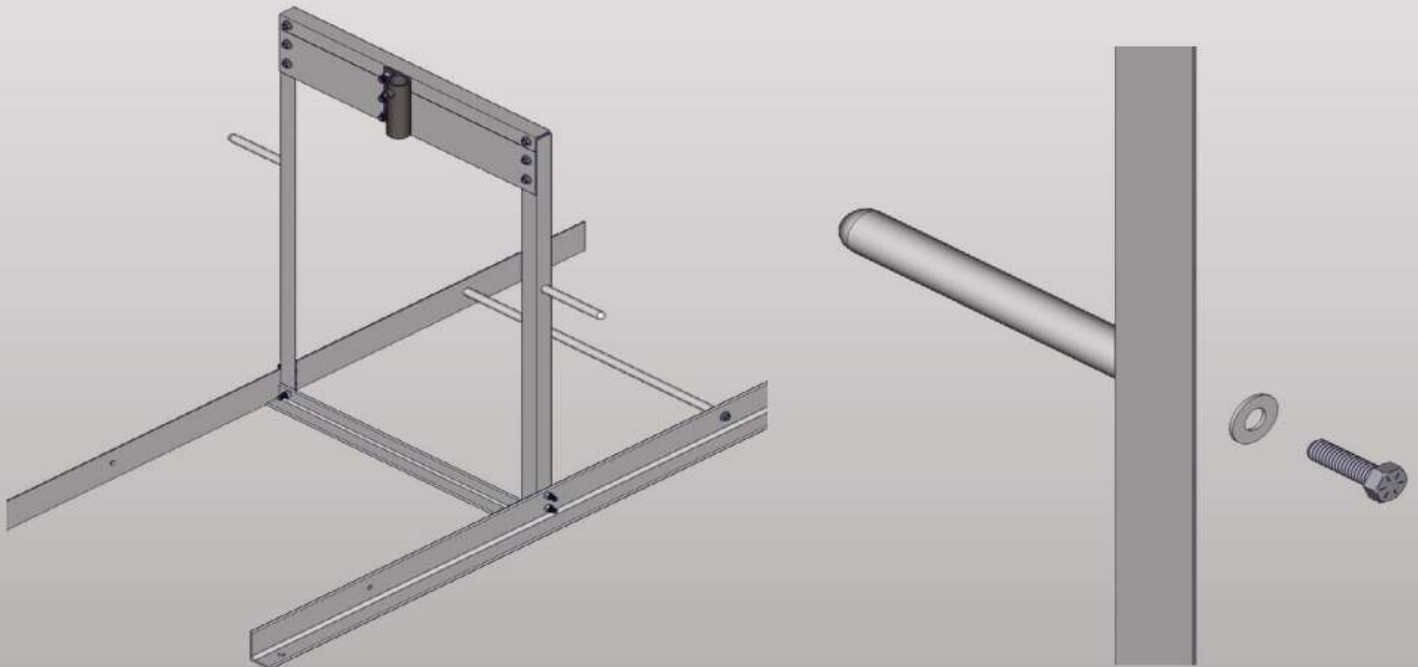

Step Seven:

Slide Pipe (J) into Horizontal Brace (F) and secure with the ½"-13 x 1 ¼" Bolt.

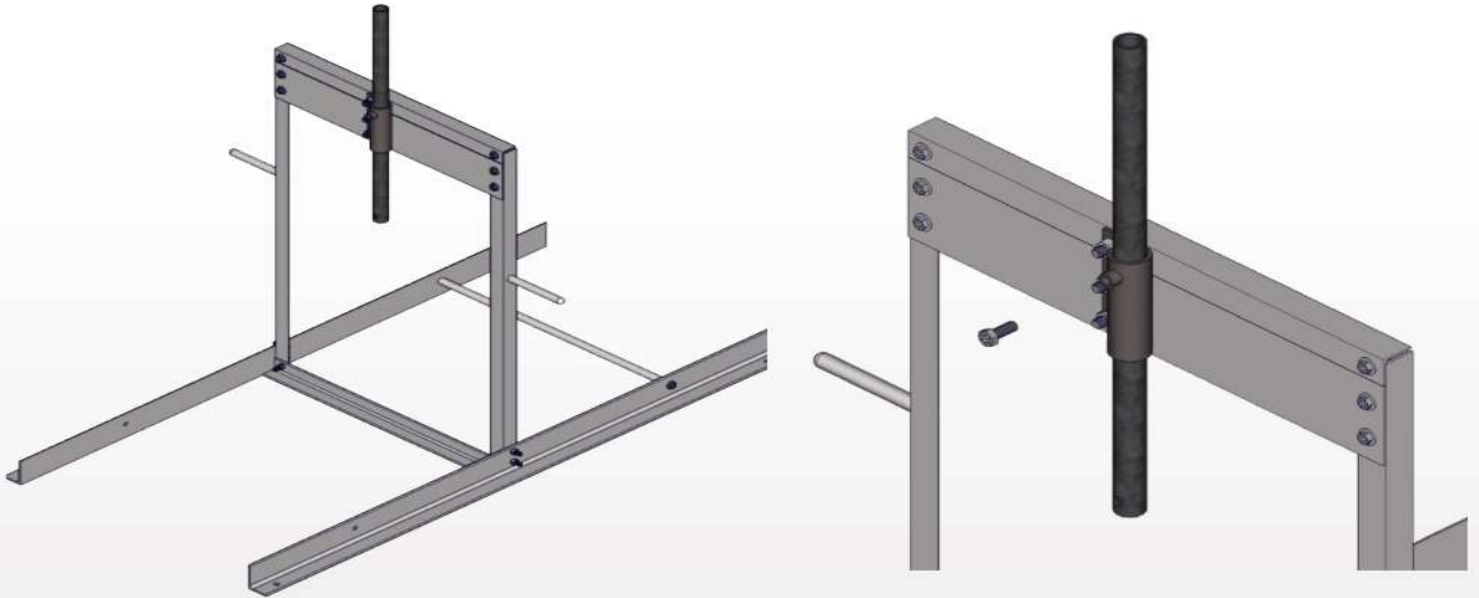

Kasco Underwater Motor Mount

A	Plate	1
B	U-bolt	2
C	5/16"-18 serrated flange nut	4
D	3/8"-16 x 1" serrated flange screw	2
E	3/8"-16 serrated flange nut	2
F	Can strap	1

