

DRONIUM ONE AP™ DRONE WITH CAMERA

INSTRUCTION MANUAL

PROTOCOL®
AIR *FLY FIRST*™

THANK YOU.

Thank you for your purchase of Protocol's **Dronium One AP With Camera**. You are about to experience the best of what remote control flight has to offer. We strongly recommend that you take the time to read this manual thoroughly. It contains many tips and instructions on how to get the most out of this aircraft and maintain it for a long life.

As with any aircraft, this is a precision flying machine. Treat it well and enjoy all the fun it has to offer, flight after flight.



TABLE OF CONTENTS

01	Safety and Precautions
02	Parts
04	Remote Battery Installation
05	Installing the Blade Guard
06	Charging the Drone
07	Power-On Procedure
08	Altitude Sensor Calibration
09	Operation
11	Tips on 360° Flips
13	Speed Modes
14	Trim Adjustment
15	Troubleshooting
16	Flying Outdoors
17	Shooting Photo/Video
18	Replacement Parts & Limited Warranty

HAVE FUN, BUT SAFETY FIRST!

PRECAUTIONARY SAFETY WARNINGS:

- Read and follow instructions on how to synchronize electronics before each flight.
- To prevent damage to people or property, always avoid contact with other objects while in flight.
- Inspect aircraft prior to each flight and do not fly if damaged.
- Never expose product or any of its electronic parts to moisture, water or heat sources.
- Charge device in a cool, dry place and under adult supervision.
- Never leave the device unattended while charging.
- To prevent overheating, allow battery a cool-down period before recharging.
- To prolong engine life, allow a cool-down period between flights.
- Use only the charger and/or charging cable that is supplied with this item.
- Do not strike, cut or pierce the internal battery or subject it to hard impacts.
- Do not mix old and new batteries or mix different types of batteries.
- Never attempt to modify function of vehicle or controller or attempt repairs using parts other than those supplied by Protocol. Spare parts are available at www.protocolny.com

CAUTION:

**THIS DEVICE USES COMPONENTS THAT OPERATE AT HIGH SPEEDS.
AS WITH ANY SUCH DEVICE, USE CAUTION TO OPERATE SAFELY.**

**FAILURE TO FOLLOW ANY OF THESE GUIDELINES MAY RESULT IN
BODILY INJURY OR DAMAGE TO PERSONAL OR PUBLIC PROPERTY.**

PARTS



DRONE

1. Canopy
2. Blade Guard
3. Blade
4. Landing Gear
5. Battery Compartment
6. Camera

PARTS

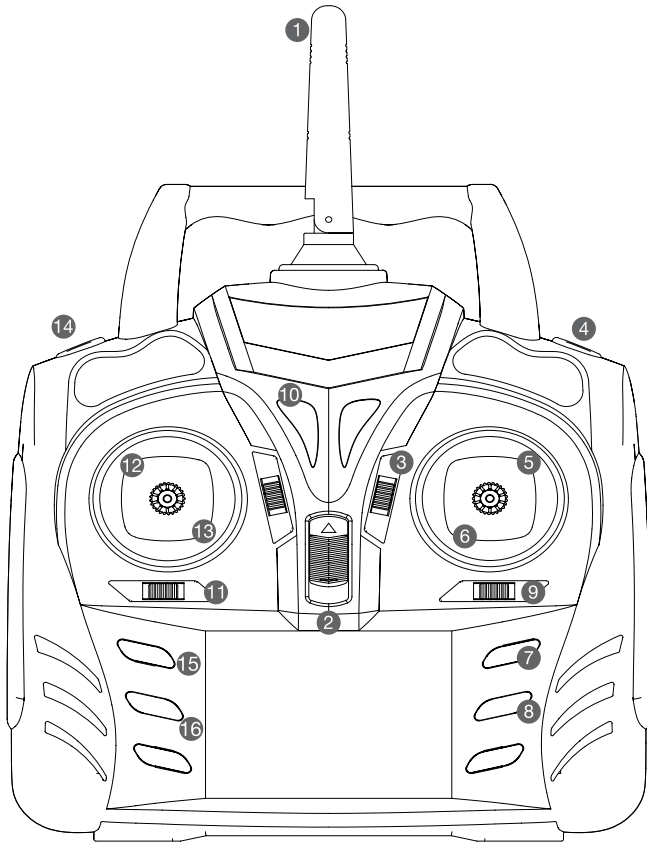

REMOTE

- | | |
|---|----------------------|
| 1. 2.4G Antenna | 15. Take Off/Landing |
| 2. Power Switch | 16. Calibration |
| 3. Trim Forward/Backward | |
| 4. Flip 360° | |
| 5. Forward/Backward | |
| 6. Bank Left/Right | |
| 7. Video | |
| 8. Photo | |
| 9. Trim Bank Left/Right | |
| 10. Indicator Light | |
| 11. Trim Turn Left/Right. The button on this unit is disabled as it was upgraded to auto trim for left/right turns. | |
| 12. Throttle | |
| 13. Turn Left/Right | |
| 14. Speed Mode Selector | |

REMOTE BATTERY INSTALLATION

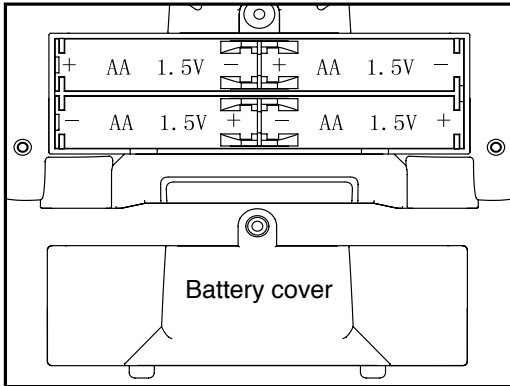

Unscrew and remove battery cover from controller. Insert 4 x 'AA' batteries according to indicated polarities. Replace and screw back in battery cover.

1. Install batteries carefully.
2. Do not mix old and new batteries.
3. Do not mix different types of batteries.

INSTALLING THE BLADE GUARD

If not already installed, install the included blade guards to every corner and tighten the screws. Make sure the blade guards are secure and snug.

NOTE: Loose blade guards may interfere with propeller movement and cause a crash. If the drone crashes, double check to make sure the blade guard is not loose. If it is, re-tighten before flying.



CHARGING THE DRONE BATTERY

1. Make sure the drone is turned off.
2. Open the battery cover and remove the battery.
3. Connect the USB charging cable to the battery.
4. Plug the charger into a USB port. The USB light will turn off while charging and will turn on once fully charged.
5. Plug the battery back into the drone and close the battery cover.
Charging time: 60 minutes --- Flying time: approximately 7 minutes.

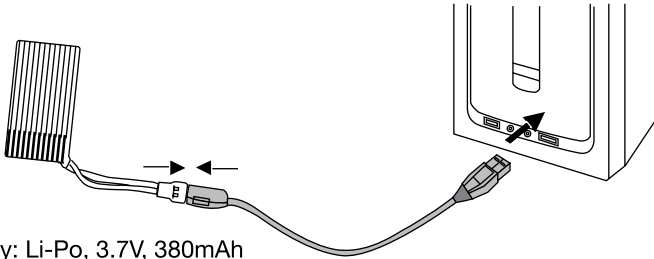

*Battery: Li-Po, 3.7V, 380mAh

If you purchased extra batteries, allow the engines to cool between flights in order to prolong engine life.

CAUTION WHEN CHARGING

1. When charging, place product on a dry, well-ventilated surface and keep away from heat sources.
2. Always use adult supervision while charging.
3. In order to increase battery longevity, avoid repeat charging and excessive discharging.
4. As battery temperature is high immediately after flight, charge after cooling down for higher efficiency.
5. Do not strike or subject battery to hard impacts or sharp surfaces.
6. Do not use any other charger than that which is supplied with this item.
7. Do not use or leave battery near a heat source such as fire or space heater; exposure to heat may result in reduced performance or in some cases dangerous conditions.
8. If battery is left in charging state for an extended period of time after being fully charged, the battery may automatically discharge.
9. Never leave the battery unattended during charging.
10. Do not disassemble battery.
11. Do not submerge battery in water.

POWER ON PROCEDURE

1. Turn on the drone and place it on an even surface.
2. Turn on the remote control.
3. Both indicators on the drone and the remote will flash while they are syncing.
4. Push the throttle up and then down to sync. You will hear two beeps and the lights will go steady.
5. Next, you must calibrate the Altitude Sensor. Press the calibration button once. Lights will flash quickly and then will go steady when finished. Your drone is now synchronized, calibrated, and in stand-by mode awaiting Engine Idle command.

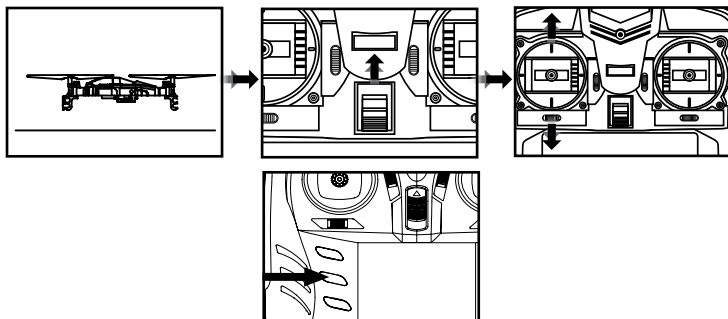

NOTE

1. While the drone is in process of synchronizing or calibrating, the lights will flash quickly. When the process is completed, the lights will go steady. This is your indication that the process is completed.
2. If after 30 seconds, it has not recognized the drone, turn off the controller and repeat Power-On procedure.
3. If the Dronium One AP is unsteady in flight, it may not have been able to calibrate properly. Power down both drone and remote and restart pre-flight procedure, including re-calibration of the altitude sensor.
4. For the Altitude Sensor to calibrate properly, the drone must be synchronized already, but the engines not spinning yet. You cannot calibrate while the propellers are turning. You have to calibrate before you start the engines.

ALTITUDE SENSOR CALIBRATION

**BEFORE STARTING THE ENGINES,
CALIBRATE THE ALTITUDE SENSOR.
DO THIS BEFORE EACH FLIGHT
EVERY TIME!**

TO CALIBRATE ALTITUDE SENSOR

Press the calibration button down once. (Fig.1)

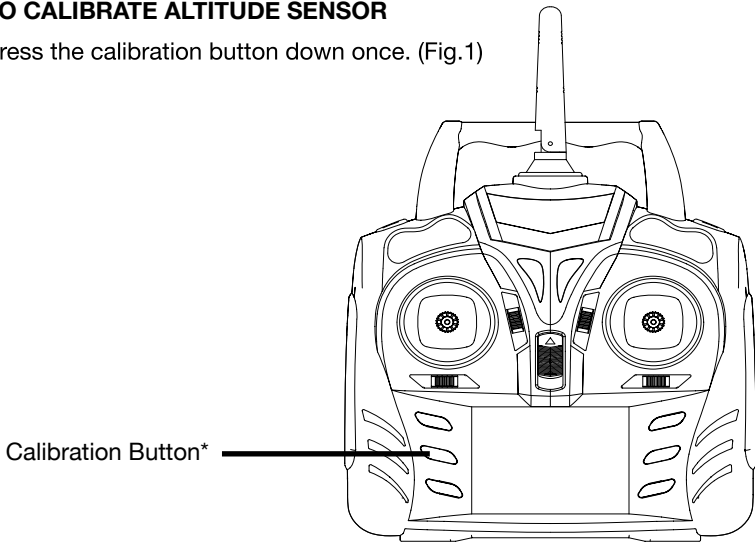

Fig. 1

* Press down once to calibrate. Lights will flash quickly during calibration and then go steady when completed. Don't worry if you press it again as it will simply recalibrate again.

NOTE:

The Altitude Sensor assists pilots by stabilizing altitude fluctuations. This stabilizing technology reduces, but does not eliminate all fluctuations. The drone may drift upwards or downwards somewhat during flight. This is normal. Manual adjustments to altitude are part of the normal piloting process.

OPERATION: FLYING THE DRONE

Starting the Engine; Engine Idle

1. After synchronizing and calibrating the drone, move the throttle and direction sticks to the lower left and lower right corners (blue lines) and release to go into Idle mode. The blades will rotate but the drone will not lift.

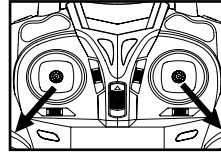

Take – Off:

1. Press the take off button. The remote will beep and the drone will hover a few feet off the ground. Then gently advance the throttle to a desired height and release. The drone will hover at that height.*

OR

2. From Idle mode, gently advance the throttle up to a desired height and release. The drone will hover at that height.*

Landing:

1. Press the landing button to lower the drone to the ground.

OR

2. Push down on the throttle until the drone is on the ground.

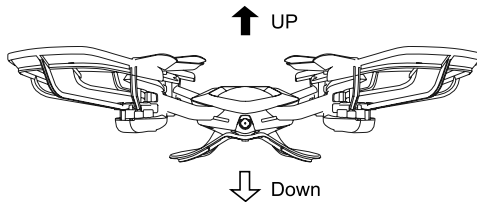
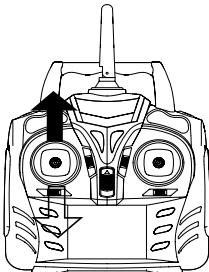

NOTE:

- The engine will shut off if you choose to hold the throttle down for 3 seconds.

- **Emergency Shut Off: When in flight, pull the throttle and direction stick to the center at the same time (red lines) and the drone will shut off.**

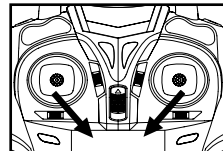

- The drone may drift a bit, especially in the first 30 seconds until the altitude sensor gets a good fix on the position. Some drift is normal.

OPERATION: FLYING THE DRONE

FIRST TIME FLYERS!!! TAKE YOUR TIME! GO SLOW!

Practice hovering until you are comfortable with flight before attempting any other maneuvers. Make small movements letting the stick return to the center. If you start to lose control, don't panic. Just press land.

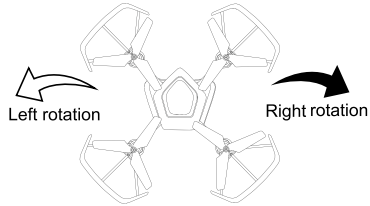
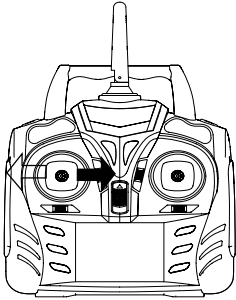

Pull the throttle left or right,
the drone turns to the left or right.

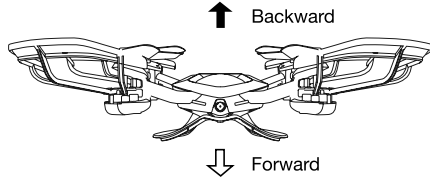
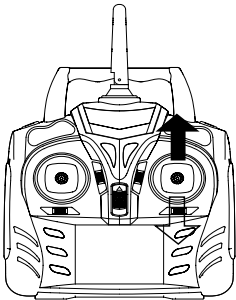

Push the direction lever up or down, the
drone flies forward or backward.

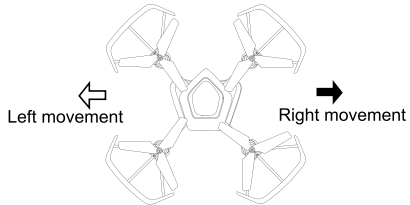
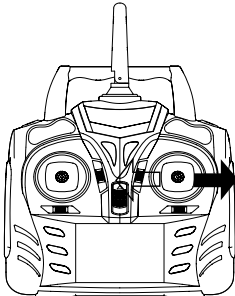

Pull the direction lever to the left or right,
the drone banks to the left or right.

TIPS ON 3D FLIPS

Once you are familiar with the basics of drone flight, you can try some advanced maneuvers! At a height of at least 10 feet, press the Flip mode button and move the direction lever in any desired direction to execute the flip. The remote will beep quickly when you are in stunt mode and will stop beeping once you have executed the flip.

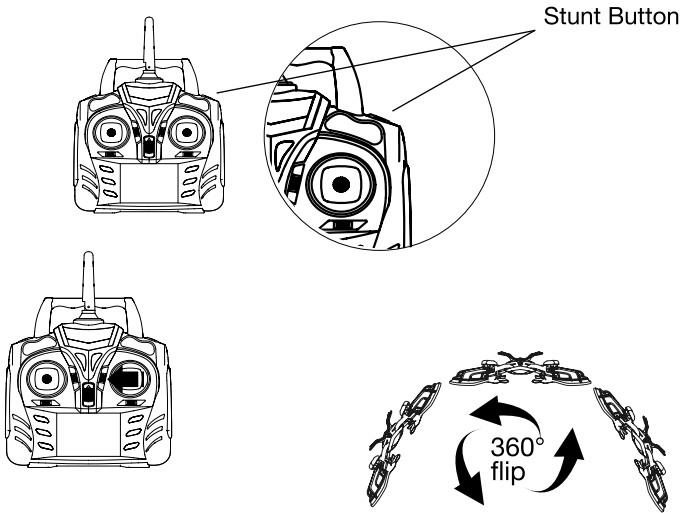

LEFT FLIP

Push the direction stick to the left and the drone will perform a 360° flip in that direction.

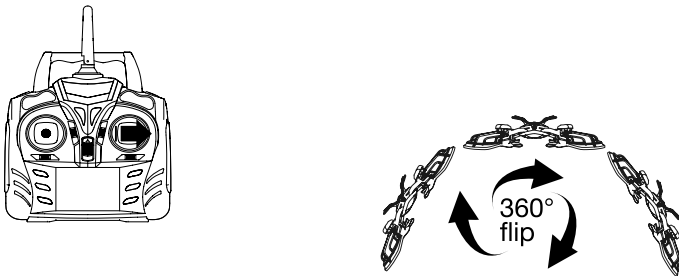

RIGHT FLIP

Push the direction stick to the right and the drone will perform a 360° flip in that direction.

TIPS ON 3D FLIPS

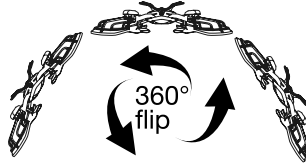
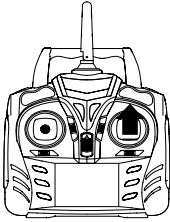

FORWARD FLIP

Push the direction stick forward and the drone will perform a 360° flip in that direction.

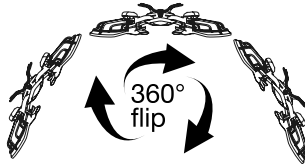
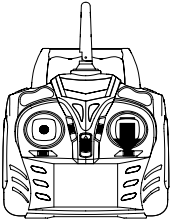

BACKWARD FLIP

Push the direction stick backward and the drone will perform a 360° flip in that direction.

SPEED MODES

The Dronium One AP features multiple speed modes. Choose the speed based on flight experience and level of comfort. At higher speeds, the drone will pitch more than at lower speeds. Dronium One AP is quite fast at its highest speed and requires more piloting skills to fly competently. For safety take time to develop advanced skills by practicing at lower speeds first. Press the Speed +/- button to change the speed mode. The remote control indicator will beep once at slowest speed mode and multiple times as speed mode is increased.

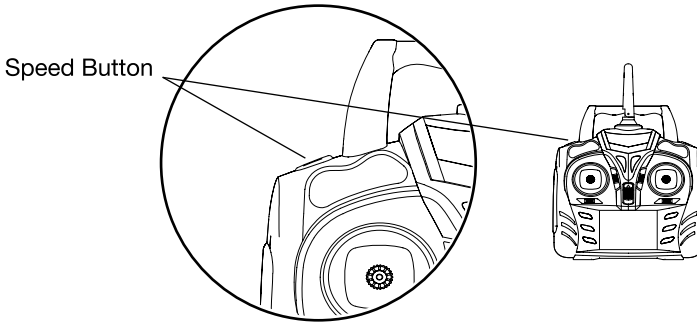

TRIM ADJUSTMENT

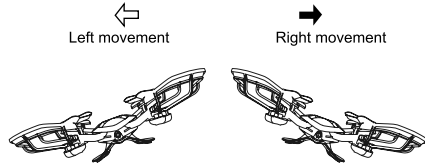
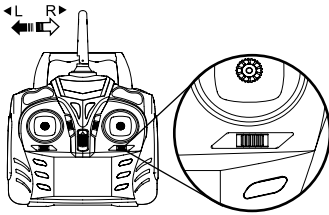

SIDWAYS TRIM

When the drone drifts to the left or right side unintentionally, you can correct it by pressing the trim button in the opposite direction until it evens out.

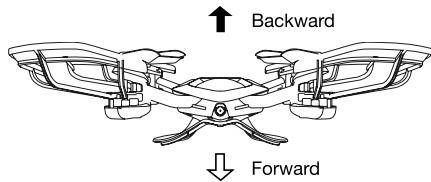
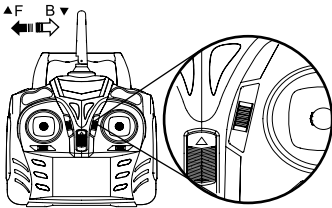

FORWARD/BACKWARD TRIM

When the drone drifts forward/backward unintentionally, you can correct it by pressing the trim button in the opposite direction until it evens out.

*NOTE: Trim adjustments are designed to counter drifts not caused by wind.

TROUBLESHOOTING

*Allow 15 minutes to pass between full flights as this will give the motors a chance to cool down. Failure to do so could wear out and shorten the life of the motors.

SYMPTOM	POSSIBLE CAUSE	POTENTIAL SOLUTION
Dronium One AP does not respond	<ol style="list-style-type: none">1. Communication between controller and aircraft was not synchronized during set up2. Battery power depleted on aircraft, controller or both.	<ol style="list-style-type: none">1. To synchronize, turn on aircraft first, place it on level ground, and then turn on controller.2. Charge aircraft and/or replace batteries in controller
Response to control inputs intermittent or erratic	<ol style="list-style-type: none">1. Controller battery power nearly depleted.	<ol style="list-style-type: none">1. Replace batteries in controller.
Dronium One AP will not hover or strafe correctly	<ol style="list-style-type: none">1. The aircraft was not on level ground during synchronization.2. Trim settings are incorrect.	<ol style="list-style-type: none">1. Re-synchronize aircraft and controller.2. Recalibrate the Altitude Sensor.3. Reset the trim buttons on the controller and re-trim flight controls.

FLYING OUTDOORS

HOW TO PREVENT FLY AWAYS

To prevent “fly-away” situations (where drones seem to fly away out of control) it is important to first test and practice within close range before letting the drone fly too far away.

Each drone is designed land if the radio signal is lost. (But, this should not be considered a landing procedure or normal flight practice.) It is important to know and test the range of your drone before flying. We recommend turning on and syncing the drone and walking away while testing the engines. Keep walking and testing until it is obvious when you reach the point where the signal is not controlling the drone. This will be the control limit for the conditions in which you are flying. Distance does vary somewhat based on environmental and weather conditions, so testing the limit is advised. Fly in a range that is good for easy visual operation of the drone.

IF YOU CAN'T SEE YOUR DRONE, THEN YOU CAN'T CONTROL YOUR DRONE.

* Fly-aways are not covered by warranty as they are overwhelmingly caused by pilot error.

SHOOTING PHOTO/VIDEO

SHOOTING PHOTOS AND VIDEO

1. Turn on the drone, synchronize, and calibrate.
2. Photo: Push the Photo button and the camera will take a photo. The red indicator on the back of the drone will flash once as it's taking the picture.
3. Video: Push the Video and the camera will begin to record. The red indicator will continuously flash while recording video. Push the Video button again and the camera will stop recording.
4. Connect the USB transfer cable to the drone and plug it into the USB port of your computer. If you are using Windows, the USB will come up on the removable drive. If you are using OS, then the USB will come up as "Untitled".
5. Open the drive and then open the Video or Photo folders to access the .AVI or JPEG files.
6. .AVI movies can be played in several different formats including Quick-time, Windows Media Player, and RealPlayer.

WARNING: Never remove the card from the video camera while the drone is turned on

REPLACEMENT PARTS

Thank you for your purchase of Protocol's **Dronium One AP with Camera**. We know that accidents can sometimes happen and that is why we offer spare parts kits on our website: **ProtocolNY.com**.

LIMITED WARRANTY

At Protocol, we're dedicated to bringing you innovative and well-designed products that make living fun and easy. We stand behind all of our products and warrant this to be free from defects in workmanship and materials for 30 days from the date of purchase. The warranty does not cover transportation damage, misuse, accident, or similar events. Specific legal rights pertaining to this warranty may vary by state.

For service claims or questions please consult our website **ProtocolNY.com**.

PROTOCOL®