

PROTOCOL®

VERT I™

VERTICAL TAKE OFF / LANDING RC PLANE

INSTRUCTION MANUAL

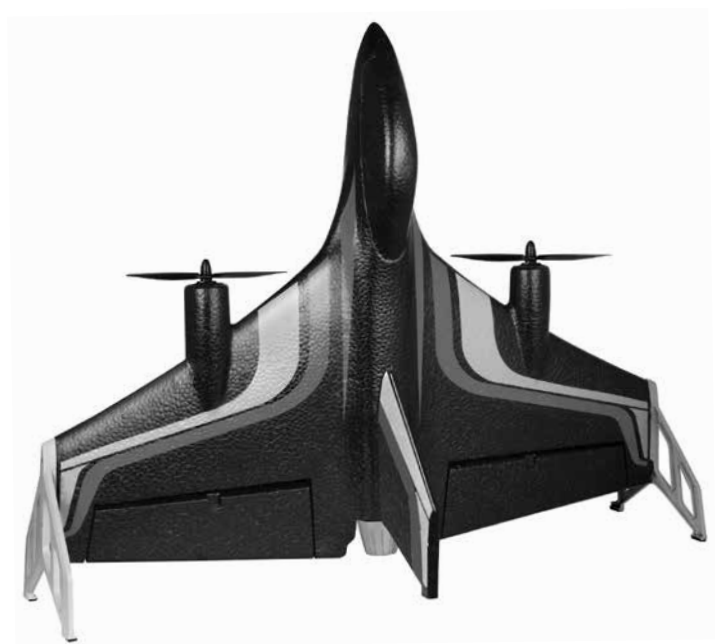

THANK YOU.

Thank you for your purchase of Protocol's **Vert I Vertical Take Off / Landing RC Plane**. You are about to experience the best of what remote control flight has to offer. We strongly recommend that you take the time to read this manual thoroughly. It contains many tips and instructions on how to get the most out of this aircraft and maintain it for a long life.

As with any aircraft, this is a precision flying machine. Treat it well and enjoy all the fun it has to offer, flight after flight.

TABLE OF CONTENTS

01	Safety & Precautions
02	Parts
04	Remote Battery Installation
05	Plane Set Up
06	Charging the Plane
07	Start-Up Procedure
08	Flying the Plane
10	3D Stunt Mode
11	Trim Adjustment
12	Troubleshooting
13	Flying Outdoors
14	Replacement Parts & Limited Warranty

SAFETY WARNINGS

HAVE FUN, BUT SAFETY FIRST!

- Read and follow instructions on how to synchronize electronics before each flight.
- To prevent damage to people or property, always avoid contact with other objects while in flight.
- Inspect aircraft prior to each flight and do not fly if damaged.
- Never expose product or any of its electronic parts to moisture, water, or heat sources.
- To prevent overheating, allow battery a cool-down period before recharging.
- To prolong engine life, allow a cool-down period between flights.
- Use only the charger and/or charging cable that is supplied with this item.
- Do not strike, cut, or pierce the internal battery or subject it to hard impacts.
- Do not mix old and new batteries or mix different types of batteries.
- Never attempt to modify function of vehicle or controller or attempt repairs using parts other than those supplied by Protocol. Spare parts are available at www.ProtocolNY.com

**THIS DEVICE USES COMPONENTS THAT OPERATE AT HIGH SPEEDS.
AS WITH ANY SUCH DEVICE, USE CAUTION TO OPERATE SAFELY.**

**FAILURE TO FOLLOW ANY OF THESE GUIDELINES MAY RESULT IN BODILY
INJURY OR DAMAGE TO PERSONAL OR PUBLIC PROPERTY.**

PARTS

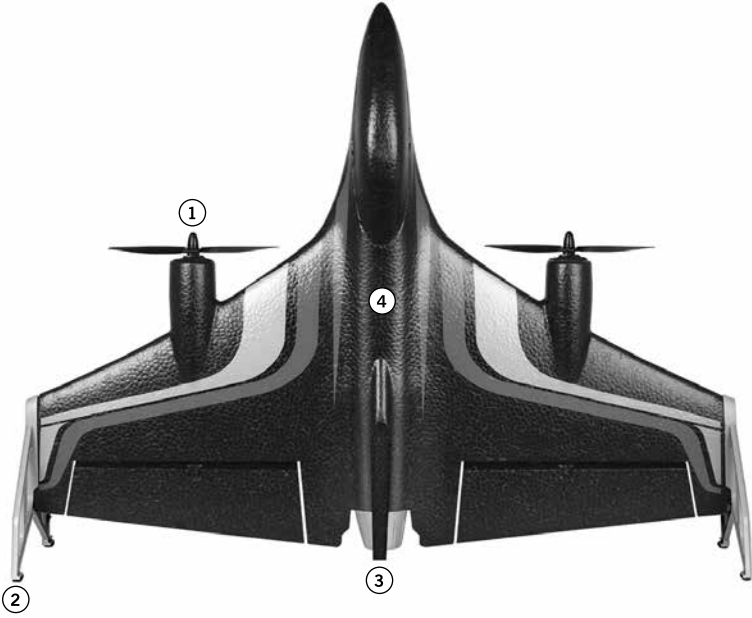

PLANE

1. Propeller
2. Vertical Wing
3. Vertical Tail
4. Body

- * Not pictured
- Landing Gear
 - Battery Compartment

PARTS

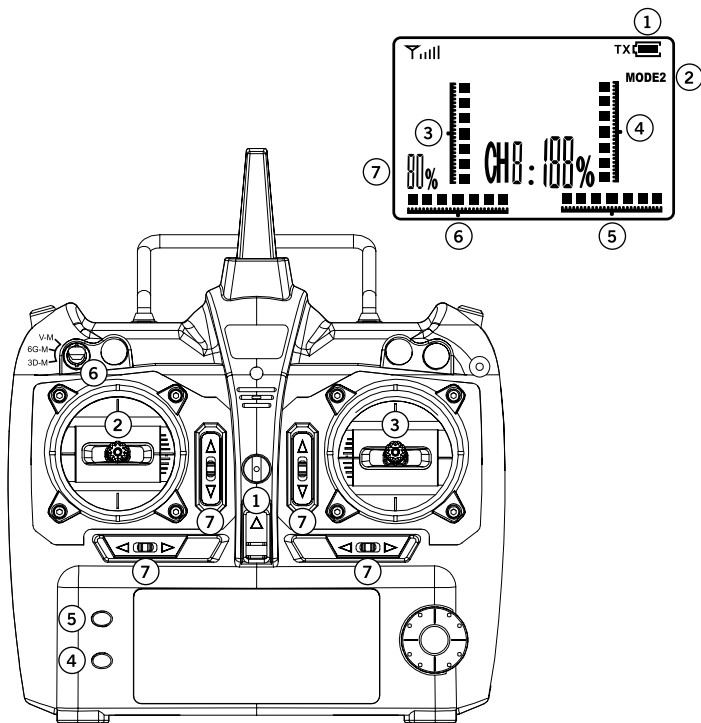

REMOTE

1. Power On/Off
2. Throttle (Mode 2);
Direction Stick (Mode 1)
3. Direction Stick (Mode 2);
Throttle (Mode 1)
4. Take Off/Land
5. Mode/Throttle Adjustment
6. Vertical, 6G, 3D Flight Switch
7. Trimmer

MODE 1 & MODE 2 ADJUSTMENT (Optional)

The plane is preset to Mode 2.
Switching between Mode 2 and
1 is optional.

LCD SCREEN

1. Remote Battery Level
2. Mode Indicator
3. Throttle Trim
4. Forward/Backward Trim
5. Bank Left/Right Trim
6. Spin L/R Trim
7. Rudder Adjustment – press
to adjust sensitivity to either
80% or 100%.

SPARE PARTS INCLUDED

- Replacement Blades

REMOTE BATTERY INSTALLATION

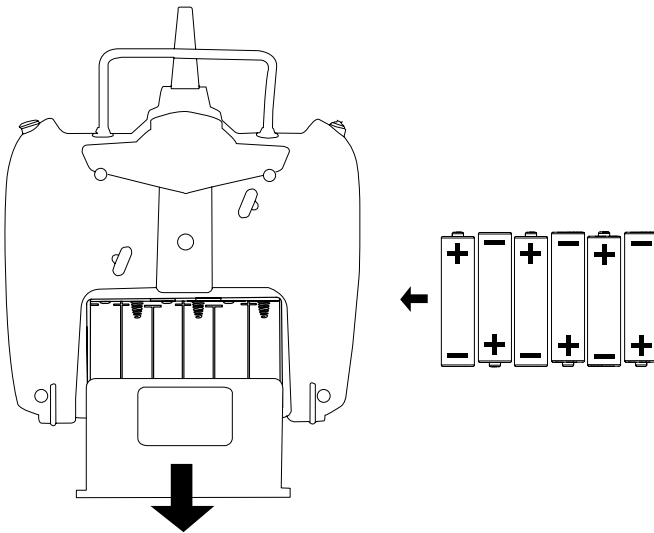

Remove battery cover from controller. Insert 6 x 'AA' batteries according to indicated polarities. Replace and screw back in battery cover.

1. Install batteries carefully.
2. Do not mix old and new batteries.
3. Do not mix different types of batteries.

MODE 1 & MODE 2 ADJUSTMENT (OPTIONAL)

1. The plane is preset to Mode 2. If you want to switch the functions of the left and right joysticks, press and hold the mode button while turning on the remote.
2. The throttle stick in either mode must be tight while the direction stick in either mode must be loose.
3. To adjust the screws, open the tabs on the back of the remote (Fig 1).
4. Using the screwdriver, loosen or tighten the screws. Do not loosen the screws too much as they will fall out.
5. If you're switching from Mode 2 to Mode 1, loosen the left stick and tighten the right. To switch back to Mode 2, re-tighten the left stick and loosen the right.
6. Place the tabs back into place.

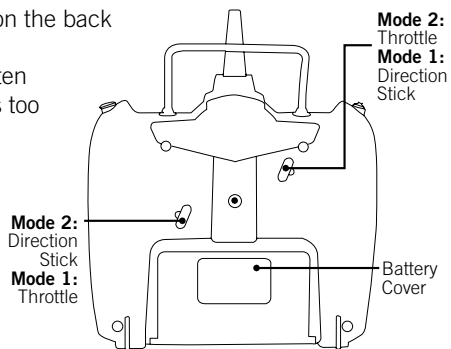

FIG. 1

PLANE SET UP

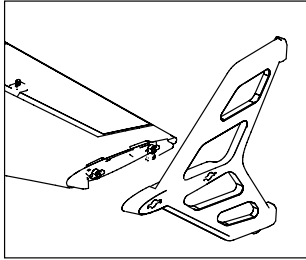

FIG. 1

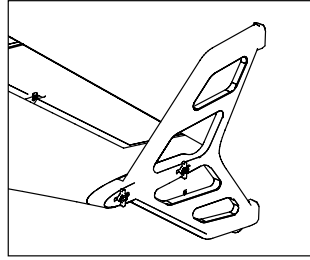
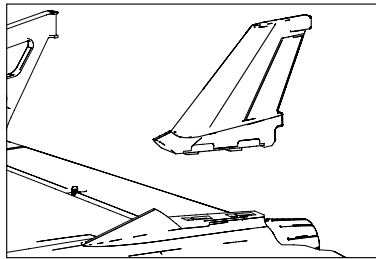

FIG. 2

Installing Wingtips

1. Slide each wingtip onto the wing of the plane (Fig.1).
2. Loosen the screws and flip the locks (Fig. 2).
3. Re-tighten the screws.



Installing Vertical Tail

Place the vertical tail into the slots on the plane and slide forward until it locks into place.

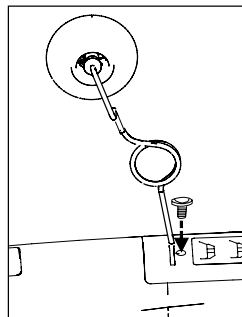
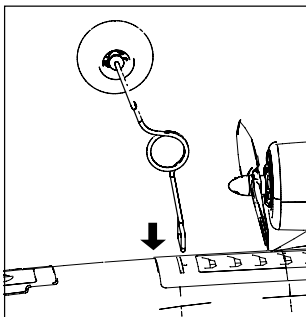

Installing Landing Gear

Slide the landing gear into the slot on the plane and screw into place.

CHARGING THE PLANE BATTERY

1. Plug the battery into the power pack and connect the power pack to the charging cord.
2. Plug the cord into an outlet. The red light on the pack will turn on while charging and turn off once charged.
3. Remove the battery from the pack once charged.

Charging time: 90 minutes --- Flying time: approximately 12 minutes

*Low Battery Signal:
The plane will start
to slow down.

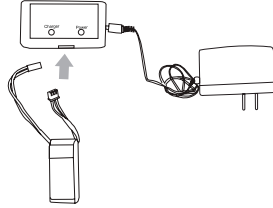

DO NOT CHARGE OVERNIGHT OR BEYOND THE CHARGING TIME STATED.
DO NOT LEAVE BATTERY UNATTENDED.

*Battery: Li-Po, 7.4V, 900mAh

If you purchased extra batteries, allow the engines to cool between flights
in order to prolong engine life.

CAUTION WHEN CHARGING

1. When charging, place product on a dry, well-ventilated surface and keep away from heat sources.
2. Always use adult supervision while charging.
3. In order to increase battery longevity, avoid repeat charging and excessive discharging.
4. As battery temperature is high immediately after flight, charge after cooling down for higher efficiency.
5. Do not strike or subject battery to hard impacts or sharp surfaces.
6. Do not use any other charger than that which is supplied with this item.
7. Do not use or leave battery near a heat source such as fire or space heater; exposure to heat may result in reduced performance or in some cases dangerous conditions.
8. If battery is left in charging state for an extended period of time after being fully charged, the battery may automatically discharge.
9. Never leave the battery unattended during charging.
10. Do not disassemble battery.
11. Do not submerge battery in water.

START-UP PROCEDURE

Before flying, the plane and transmitter must be turned on in sequence and synchronized.

1. Plug the battery into the plane to turn it on and place it on flat ground in front of you.
2. Turn on the remote control.
3. Switch the remote to:
 - a. V-Mode – Vertical Flight
 - b. 6G-Mode – Horizontal Flight – make sure to have area cleared to serve as a runway
 - c. 3D-Mode – Stunt Flight
4. Push the throttle up and then down to sync.

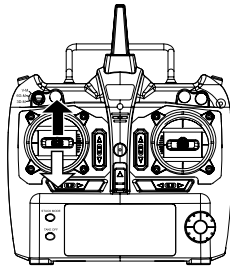

NOTE:

If after 30 seconds, it has not recognized the plane, turn off the controller and repeat Start-Up procedure.

STARTING THE ENGINE

After synchronizing the plane, pull the throttle and direction stick to lower outer corners at the same time and release. The blades will rotate but the plane will not lift.

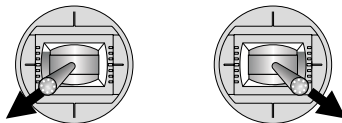

OPERATION: FLYING THE PLANE

TAKE-OFF:

1. Make sure the throttle is in the center position. Press and hold the take off button. The plane will hover a few feet off the ground. Then gently advance the throttle to a desired height and release. The plane will hover at that height.*

Or

2. From Idle mode, gently advance the throttle up to a desired height and release. The plane will hover at that height.*

LANDING:

1. Press and hold the take off button again to lower the plane to the ground.

OR

2. Push down on the throttle until the plane is on the ground.

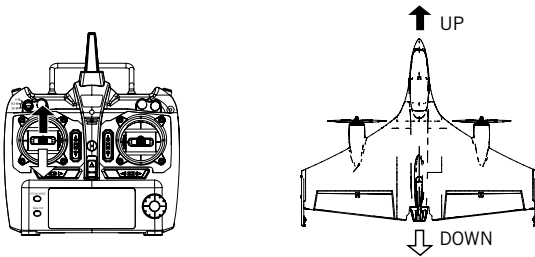

NOTE:

- **Emergency Shut Off: When in flight, press the Take Off button and the circle button at the same time and the plane will shut off.**

* The plane may drift a bit, especially in the first 30 seconds until the altitude sensor gets a good fix on the position. Some drift is normal.

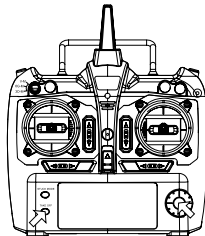

OPERATION: FLYING THE PLANE

Note: You can switch between V, 6G, and 3D mode during flight.

FIRST TIME FLYERS!!! TAKE YOUR TIME! GO SLOW!

Practice hovering until you are comfortable with flight before attempting any other maneuvers. Make small movements letting the stick return to the center. If you start to lose control, don't panic. Just pull down the throttle.

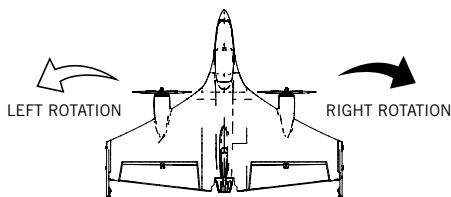
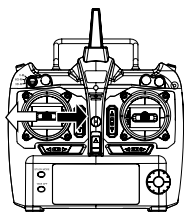

Pull the throttle left or right,
the plane turns to the left or right.

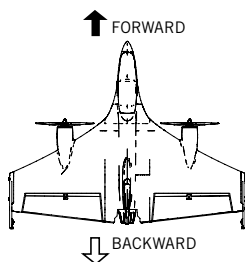
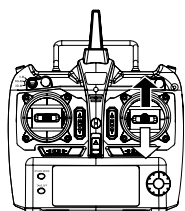

Push the direction lever up or down,
the plane flies forward or backward.

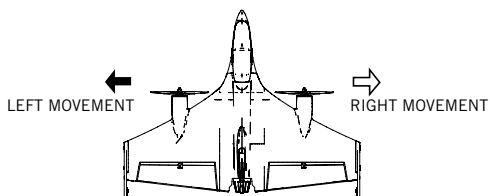
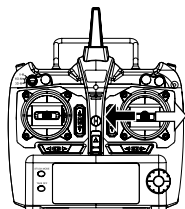

Pull the direction lever to the left or right,
the plane banks to the left or right.

3D STUNT MODE

3D Mode will remove the auto-stabilizers and allow the plane to perform stunts. This is best for advanced users as it is more difficult to control the plane in this mode.

Make sure you have plenty of space to perform the stunts and the area is clear of people and obstacles.

In 3D Stunt Mode, you can perform loops and rolls:

Loop:

1. Fly straight and level with the throttle at its center.
2. Push the throttle to full power and hold.
3. Gently pull back all the way on the direction stick and hold.
4. When the plane is completely upside down, gently pull the throttle all the way down while leaving the direction stick in place.
5. Next, gently push the direction stick back to its center and increase the throttle to even out the plane.

Roll:

1. Fly straight and level with the throttle at its center.
2. Push the direction stick up and then to the left or right immediately after.
3. Return the direction to the center immediately after the plane completes a roll.

TRIM ADJUSTMENT

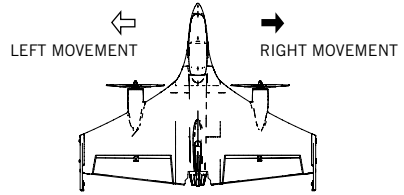
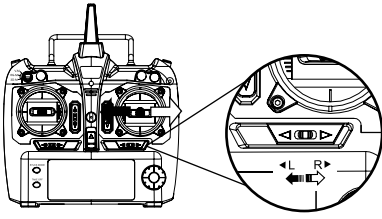

SIDEWAYS TRIM

When the plane drifts to the left or right side unintentionally, you can correct it by pressing the trim button in the opposite direction until it evens out.

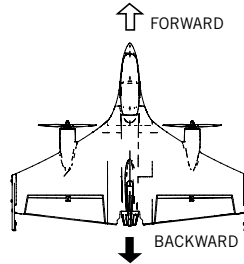
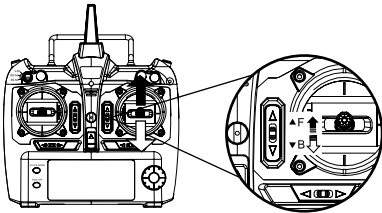

FORWARD/BACKWARD TRIM

When the plane drifts forward/backward unintentionally, you can correct it by pressing the trim button in the opposite direction until it evens out.

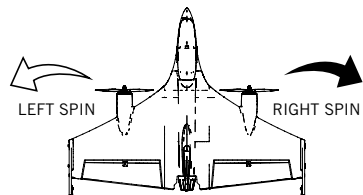
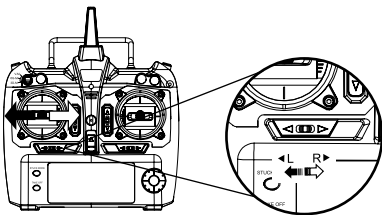

LEFT/RIGHT SPIN TRIM

When the plane spins left/right unintentionally, you can correct it by pressing the trim button in the opposite direction until it evens out.

*NOTE: Trim adjustments are designed to counter drifts not caused by wind.

THROTTLE TRIM

You can adjust the power level of the throttle by pressing the throttle trim button up or down.

TROUBLESHOOTING

*Allow 15 minutes to pass between full flights as this will give the motors a chance to cool down. Failure to do so could wear out and shorten the life of the motors.

SYMPTOM	POSSIBLE CAUSE	POTENTIAL SOLUTION
Vert I does not respond	<ol style="list-style-type: none"> 1. Communication between controller and aircraft was not synchronized during set up 2. Battery power depleted on aircraft, controller or both. 	<ol style="list-style-type: none"> 1. To synchronize, turn on aircraft first, place it on level ground, and then turn on controller. 2. Charge aircraft and/or replace batteries in controller.
Response to control inputs intermittent or erratic	<ol style="list-style-type: none"> 1. Controller battery power nearly depleted. 	<ol style="list-style-type: none"> 1. Replace batteries in controller.
Vert I will not hover or strafe correctly	<ol style="list-style-type: none"> 1. The aircraft was not on level ground during synchronization. 2. Trim settings are incorrect. 	<ol style="list-style-type: none"> 1. Re-synchronize aircraft and controller. 2. Re-trim flight controls.

HOW TO CHANGE THE BLADES

- Slide the screwdriver into the hole on the blade cap and twist to remove cap.
- Align the arrows on the blades to match the diagram.
- Slide the new blades on and screw on the blade caps.

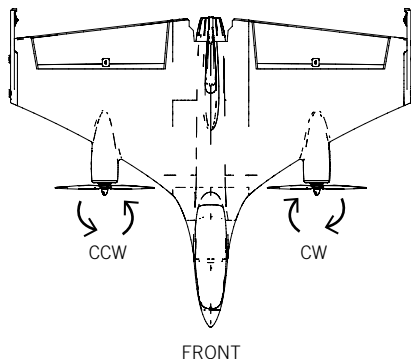

FLYING OUTDOORS

HOW TO PREVENT FLY AWAYS

To prevent “fly-away” situations (where planes seem to fly away out of control) it is important to first test and practice within close range before letting the plane fly too far away.

Each plane is designed to land if the radio signal is lost. (But, this should not be considered a landing procedure or normal flight practice.) It is important to know and test the range of your plane before flying. We recommend turning on and syncing the plane and walking away while testing the engines. Keep walking and testing until it is obvious when you reach the point where the signal is not controlling the plane. This will be the control limit for the conditions in which you are flying. Distance does vary somewhat based on environmental and weather conditions, so testing the limit is advised. Fly in a range that is good for easy visual operation of the plane.

IF YOU CAN'T SEE YOUR PLANE, THEN YOU CAN'T CONTROL YOUR PLANE.

* Fly-aways are not covered by warranty as they are overwhelmingly caused by pilot error.

REPLACEMENT PARTS

Thank you for your purchase of Protocol's **Vert 1 Vertical Take Off/Landing RC Drone**. We know that accidents can sometimes happen and that is why we offer spare parts kits on our website: **ProtocolNY.com**.

LIMITED WARRANTY

At Protocol, we're dedicated to bringing you innovative and well-designed products that make living fun and easy. We stand behind all of our products and warrant this to be free from defects in workmanship and materials for 30 days from the date of purchase. The warranty does not cover transportation damage, misuse, accident, or similar events. Specific legal rights pertaining to this warranty may vary by state.

For service claims or questions please consult our website **www.ProtocolNY.com**.



