



Barneys Mani & Pedi Spa Treatment Chair

MODEL B84200

User Manual

Please read this user manual carefully before using the product.

www.barneyssalonsupplies.com.au | 1800 676 522

1. About This Manual

This manual should only be used in reference of the operation of this particular model. If the manual is used for other purposes, or instructions not followed correctly, Barneys Salon Supplies will not undertake any consequences or responsibility.

All information in this manual shall be protected by copyright and shall not be copied and translated in any part of this specification without the written consent of the manufacturer.

2. Warning

- Do not stand on the product.
- Do not allow children play with the product.
- Do not place the equipment in damp places such as bathroom or expose to direct sunlight.
- Do not use product on an unstable surface.

3. Precautions

- Read this manual carefully before installation, operation and adjustment.
- This product should be used by an experienced person who is familiar with the product structure and performance.
- The operator must use the product only for its intended use.
- Please operate the product strictly in accordance with the warning label stamped on it.
- Do not overload the product and ensure that the product has been correctly and safely installed.
- Tighten bolts and nuts regularly to avoid product failure and to keep product secure.
- Do not operate this product if faulty. Should the product appear to behave unusually, cease using the product and inspect immediately. Do not use the product until issues have been resolved.
- Regular maintenance and troubleshooting should be processed by trained professionals.
- After every treatment, clear the dust or stains on the product using a neutral cleaning solution.
- When adjusting parts of the equipment for positioning, please keep your hands, feet and head clear from the areas indicated as shown in the image below.

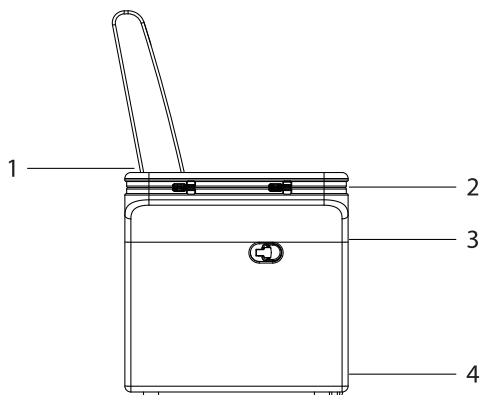

4. Installation

1. Place the product in a safe location, according to the overall layout of the treatment room.
Keep it in a clean, dry and cool environment.
2. Open the packing carton and remove all parts prior to installation.
3. Ensure all parts are included and the packing carton is checked thoroughly prior to disposing.
4. Installation:
Place the product in the proper position. Please note that it is unnecessary to install any extra screws to fasten the bed, as stability performance has been taken into consideration.
Please ensure the product is placed on a firm and flat surface for stability.
If the product seems to be unstable due to an uneven surface, please adjust the four pieces of plastic feet and nuts by using a hexagon open-end wrench to fasten on to the bottom panel.

● Installation Step:

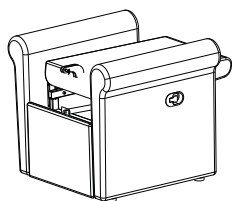

1. Take out the chair

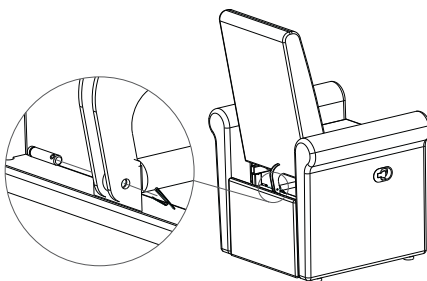

2. Pull up the backrest, connect the gas lift and backrest by pin and lock it by split cotter

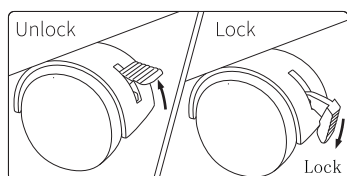

3. Fix the tray frame

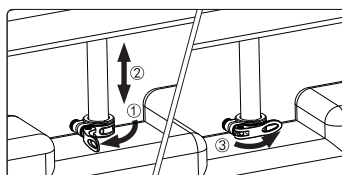

4. Adjust footrest

5. Operation Illustration

1. Open the package and take out the components, and assemble them as required before using the chair.
2. Backrest adjustment: open the right buckle of the seat to control the inclination of the backrest.
3. Tray frame adjustment: pull out the tray frame to the required position and step on the lock position on the wheel to fix it.
4. Footrest adjustment: open the handle below the footrest, adjust the footrest to the required height and push the handle to fix it.
5. If the footbath is needed, the size of the footbath should be 40×40×26cm. If the size exceeds 46×46×26cm, the footbath cannot be placed or stored in the seat.
6. Foot bath is not included.

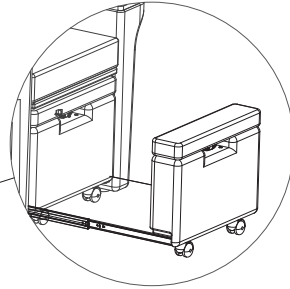
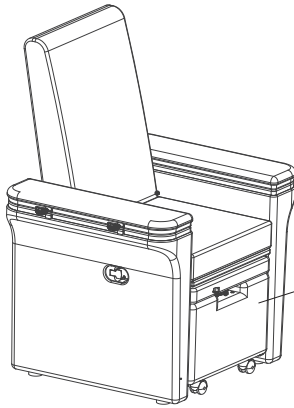
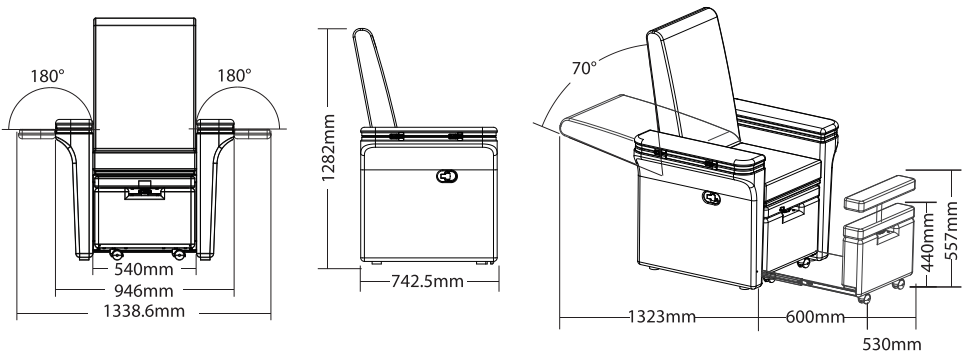

Plate for placing basin

6. Technical Parameters

Max loading capacity	Up to 175kg
Max loading capacity of Plate for placing basin	50kg

B84200



7. Maintenance

1. After every treatment, use a neutral solution to clean dust and stains.
Avoid using cleaning solutions such as alcohol, acid or alkaline solutions that could damage the surface. This is to prevent the lifetime of the components from being shortened.
2. Please lubricate the moving parts regularly (at least once a year).

8. Troubleshooting

Fault Reference	Reason	Solution
Abnormal Sound	1. The rotating parts are short of lubricating oil.	1. Add lubricating oil.
	2. Rotating positions (such as hinge, POM sets, gas lift) are short of lubricating oil.	2. Add lubricating oil.

If problems continue to persist after following above operations, please contact a qualified maintenance center or your supplier to resolve.



Do not dispose of old or defective appliances in domestic garbage; this should only be done through public collection points.

- ▲ Please check the product specification before use. This manual is for reference only. Specifications are subject to change without prior notice.