



Lincoln Beauty Trolley

MODEL B81014

User Manual

Please read this user manual carefully before using the product.

www.barneyssalonsupplies.com.au | 1800 676 522

1. About This Manual

This manual should only be used in reference of the operation of this particular model. If the manual is used for the other purposes, or instructions not followed correctly, Barneys Salon Supplies will not undertake any consequences or responsibility. All information in this manual shall be protected by copyright and shall not be copied and/or translated in any part of this specification without consent of the manufacturer.

2. Warning

- Do not stand on the product
- Do not allow children to play with the product
- Do not place equipment in damp places such as bathrooms, or expose to direct sunlight
- Do not use this product on an unstable surface









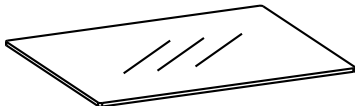

3. Precautions

- Read this manually carefully before installation, operation and/or adjustment
- Check casters, drawers, frames and screws daily, to ensure all are in safe working order
- The product must be used only for its intended use
- Please operate product strictly in accordance with the warning labels accompanying the product
- Do not overload the products, and ensure that the product has been correctly and safely installed
- Do not operate this product if faulty. Should the product appear to behave unusually, cease use and inspect immediately. Do not use the product again until issues have been resolved
- Regular maintenance and troubleshooting should be processed by trained professional
- After each treatment, remove dust or stains using a neutral cleaning solution

4. Assembly and Operation

1. Place the product in a safe location, according to the overall layout of the treatment room. Keep the product in a clean, dry and cool environment
2. Open the packing carton and remove all parts prior to installation
3. Ensure all part are included and the packaging carton is checked thoroughly prior to disposing
4. Installation:
Below graphics are for illustration purposes. Refer to actual product structure for assembly.

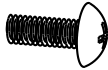
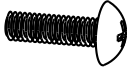
B81014 Components

NO.	Name	Sample	Quantity
A	Glass		3
B	Wheel		4
C	Baluster		3
D	Metal frame for left-1		1
E	Metal frame for right-1		1
F	Metal frame for left-2		1
G	Metal frame for right-2		1
H	Accessories-1		3
I	Screw (M6 × 20)		13
J	Screw (M6 × 35)		5
K	PVC Tray		13

B81014 Installation Procedure

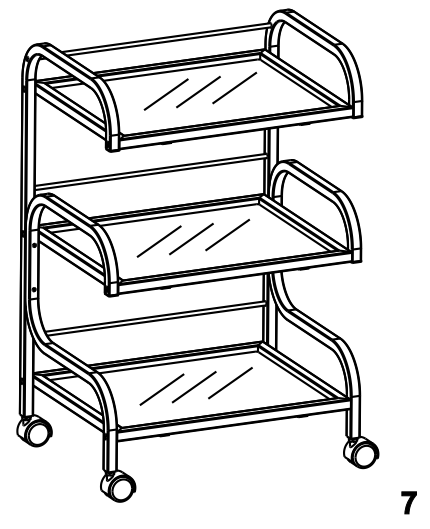
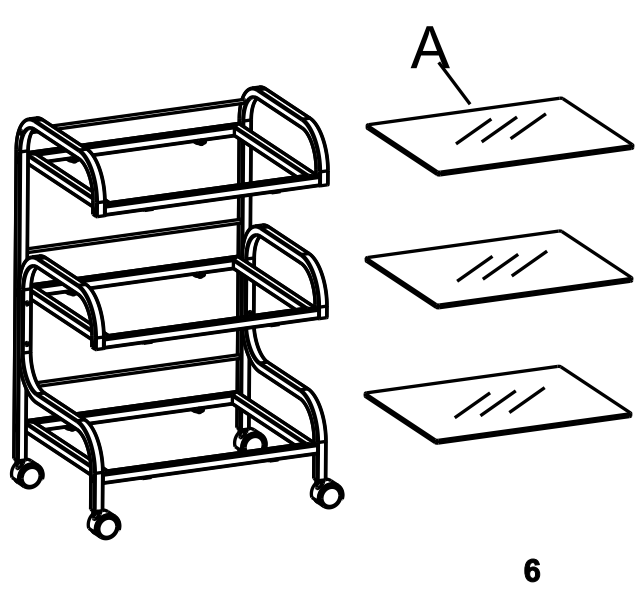
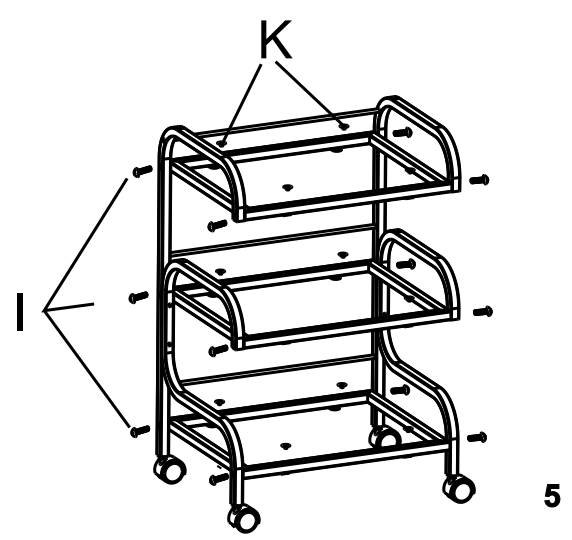
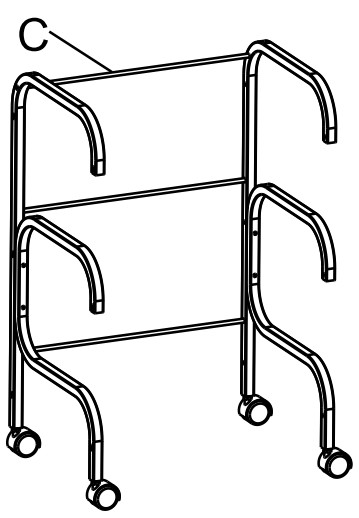
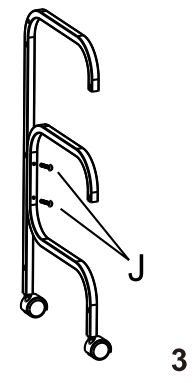
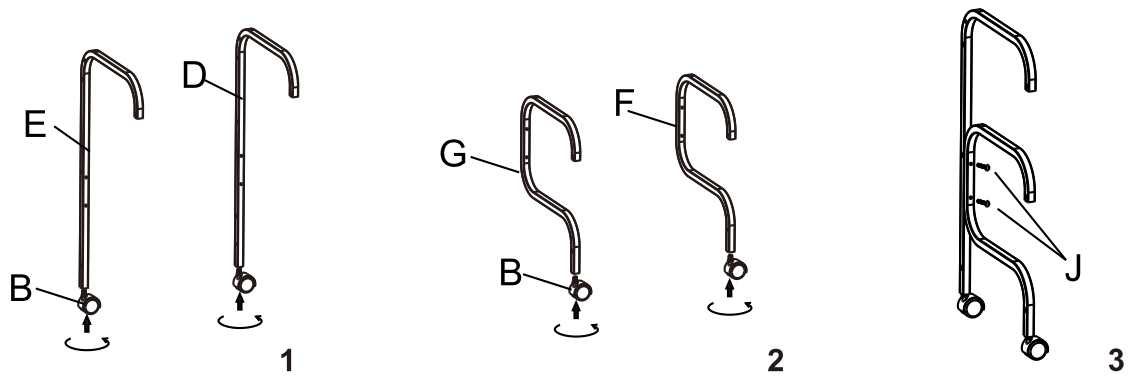

5. Technical Parameters

Lifting Rated Load	30kg
Package Size	850 x 440 x 140mm
Net Weight	13.5kg
Gross Weight	14.5kg

B81014

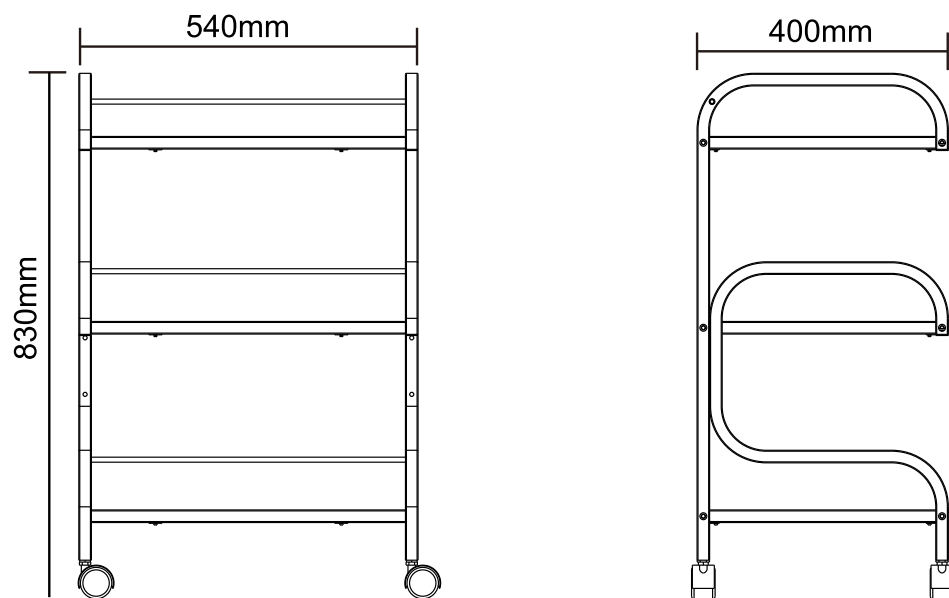

10. Maintenance

- After every treatment, use a neutral solution to clean dust and stains
- Avoid using cleaning solutions such as alcohol, acid or alkaline solutions that could damage the material. This is to prevent the lifetime of the components from being shortened
- Please lubricate the moving parts regularly (at least once a year)



Do not dispose of old or defective appliances in domestic garbage; this should only be done through public collection points.

▲ Please check the product specification before use. This manual is for reference only. Specifications are subject to change without prior notice.