

ITEM NO.	QTY. PER CALIPER	QTY. PER AXLE	PART NUMBER	USED ON	DESCRIPTION	FINISH	CALIPER ASSY REF'
1	1	2	BCC 0482	NS & OS	ANGLESEY 16 CALIPER	SEE TABLE	BCC 0216A NS BCC 0216A OS
2	1	2	BCC 0483		ANGLESEY 16 CALIPER		
3	2	4	BCC 0084		Ø38 LR PISTON		
4	1	2	BCC 0044		Ø38 SEAL KIT *		
5	4	2	BCC 0085		Ø36 PISTON		
6	1*	8	BCC 0086		Ø36 SEAL KIT *		
7	4	8	BCC 0171		CAP HD' SCREW, 55 LG'		
8	2	4	BCC 0172		CAP HD' SCREW, 60 LG'		
9	6	12	BCC 0242		WASHER, SPECIAL		
10	2	4	BCC 0289		Ø6 x 20 DOWEL PIN		
11	1	2	BCC 0088		M10x1 BLEED NIPPLE		
12	2	4	BCC 0139		INTERNAL BRIDGE SEAL		
13	2	4	BCC 0386		BLANKING PLUG, M10 x 1P		
14	1	2	BCC 0340		BLEED NIPPLE COVER		
15	1	2	CMCP2SR		12.6 FLUID PORT DUST CAP		

ANGLESEY FRONT CALIPER ASSEMBLY (NS & OS)

EXPLODED VIEW SHOWING BASIC CALIPER SUB ASSEMBLY - SEE SHEET 2 FOR FULL ASSEMBLY

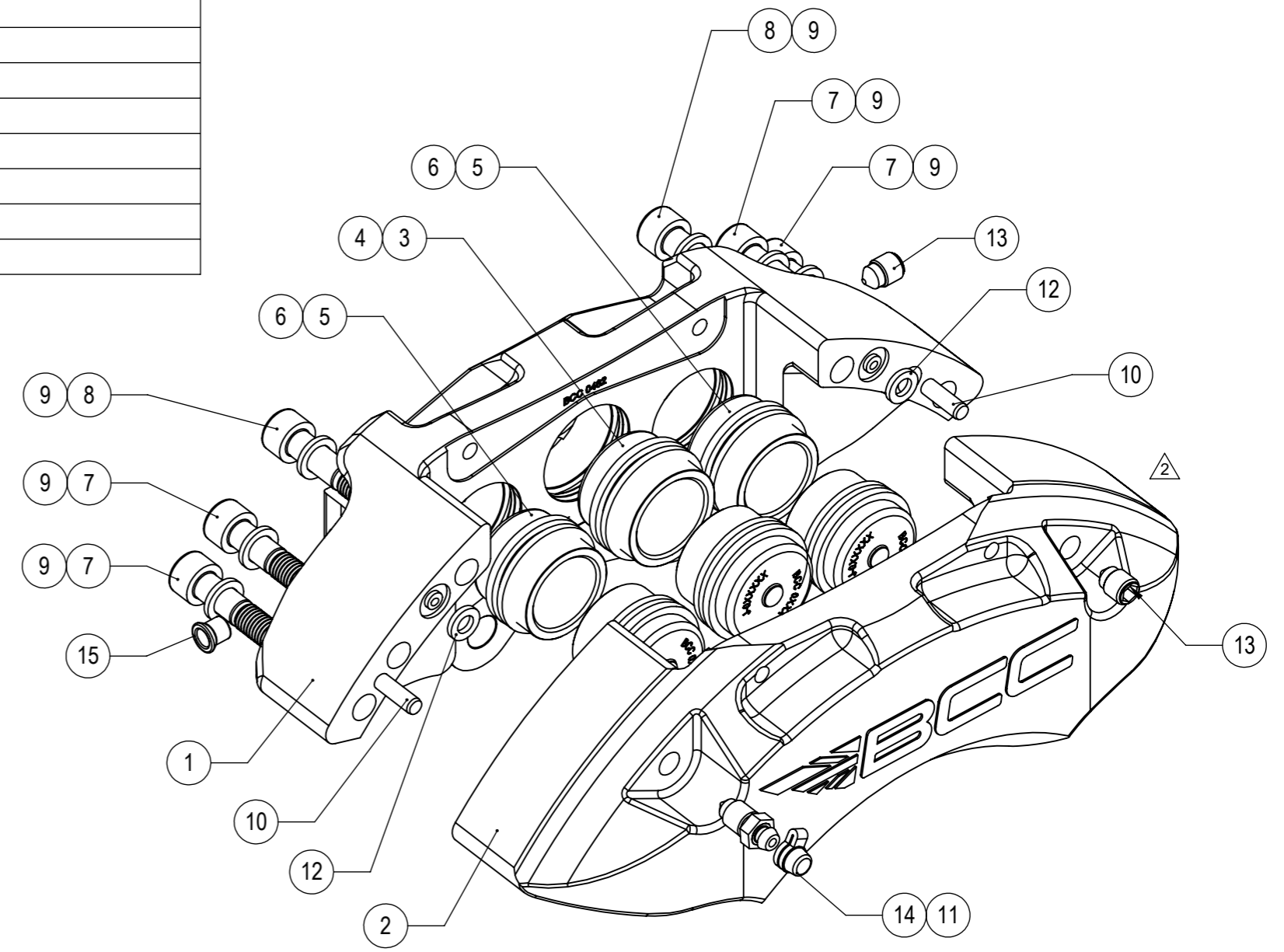

* Ø36 SEAL KIT COMPRISES OF 4x FLUID AND 4x DUST SEAL.
** Ø38 SEAL KIT COMPRISES OF 2x FLUID AND 2x DUST SEAL.



FINISH		
CALIPER PART NO.	PART NO. COLOUR: RED	PART NO. COLOUR: BLACK
BCC 0482	BCC 0482-R	BCC 0482-B
BCC 0483	BCC 0483-R	BCC 0483-B

ASSEMBLY INFORMATION:

- BOLT TORQUE TO BE SET AT 80Nm.
- PIPE NIPPLES: TORQUE TO 10.5Nm.
- GRANVILLE RED RUBBER GREASE (BCC 0256) TO BE USED WHEN ASSEMBLING SEALS TO CALIPER.
- W/I 34 TO BE USED FOR ASSEMBLY AND TESTING PROCEDURES.

NEAR SIDE SHOWN, OFF SIDE IS OPPOSITE CONFIGURATION (RHD) [△]
BLEED NIPPLE ALWAYS UPPERMOST WHEN MOUNTED

SHEET 1

DIMENSIONS ARE IN MILLIMETERS. NO DECIMAL PLACE ± 0.50 ONE DECIMAL PLACE ± 0.25 TWO DECIMAL PLACES ± 0.10 ANGULAR DIMENSIONS : ± 0.25° BEND: ± 0.5° SURFACE FINISH : Ra1.6 UNLESS STATED OTHERWISE. CRITICAL DIMENSION		 BRITISH MADE CLASSIC CAR PARTS http://www.britishclassiccarparts.com +44(0)1209 202800 info@bcc-parts.com	CUSTOMER: BCC															
<table border="1"> <tr> <td>DESIGN TYPE</td> <td>SIMPLE</td> <td>HEAT TREATMENT:</td> </tr> <tr> <td></td> <td>COMPLEX X</td> <td>-</td> </tr> <tr> <td>MATERIAL:</td> <td>SEE BOM</td> <td>FINISH:</td> </tr> <tr> <td></td> <td></td> <td>SEE BOM</td> </tr> </table>			DESIGN TYPE	SIMPLE	HEAT TREATMENT:		COMPLEX X	-	MATERIAL:	SEE BOM	FINISH:			SEE BOM				
DESIGN TYPE	SIMPLE	HEAT TREATMENT:																
	COMPLEX X	-																
MATERIAL:	SEE BOM	FINISH:																
		SEE BOM																
<table border="1"> <tr> <td>NAME</td> <td>SIGNATURE</td> <td>DATE</td> </tr> <tr> <td>DRAWN SM</td> <td></td> <td>21/08/2020</td> </tr> <tr> <td>CHK'D JG</td> <td></td> <td>16/03/21</td> </tr> <tr> <td>APP'VD JG</td> <td></td> <td>19/03/21</td> </tr> <tr> <td>MFG RA</td> <td></td> <td>18/03/21</td> </tr> </table>		NAME	SIGNATURE	DATE	DRAWN SM		21/08/2020	CHK'D JG		16/03/21	APP'VD JG		19/03/21	MFG RA		18/03/21	 THIRD ANGLE PROJECTION PROPRIETARY AND CONFIDENTIAL THE INFORMATION CONTAINED IN THIS DRAWING IS THE SOLE PROPERTY OF BC Car Parts Ltd. ANY REPRODUCTION IN PART OR AS A WHOLE WITHOUT THE WRITTEN PERMISSION OF BC Car Parts Ltd IS PROHIBITED.	TITLE: ANGLESEY 16 CALIPER
NAME	SIGNATURE	DATE																
DRAWN SM		21/08/2020																
CHK'D JG		16/03/21																
APP'VD JG		19/03/21																
MFG RA		18/03/21																
DEBUR AND BREAK SHARP EDGES		DWG NO. BCC 0216A	A3															
LOCATION: F:\Solidworks\BCC\BRAKES\ASSEMBLIES\BCC 0216 - ANGLESEY 16\		SCALE: .	REVISION: 2															

BCC A3L

ITEM NO.	QTY. PER CALIPER	QTY. PER AXLE	PART NUMBER	DESCRIPTION	COMMENTS
16	2	4	BCC 0188	BRAKE PAD PIN	
17	2	4	BCC 0163	BRAKE PAD SPRINGS	
18	0.5	1	DP41462R	BRAKE PAD	
19	1	2	BCC 0132 **	210mm M10 FEED PIPE ASSY	SEE NOTE BELOW, RE: PIPE VERSION
20	1	2	BCC 0257 **	210mm M10 FEED PIPE ASSY	
23	4	8	BCC 0246	1.2MM R-CLIP	

ANGLESEY FRONT CALIPER FULL ASSEMBLY (NS & OS)

** BRAKE PADS ARE SUPPLIED AS A BOX OF FOUR (2 PER CALIPER)

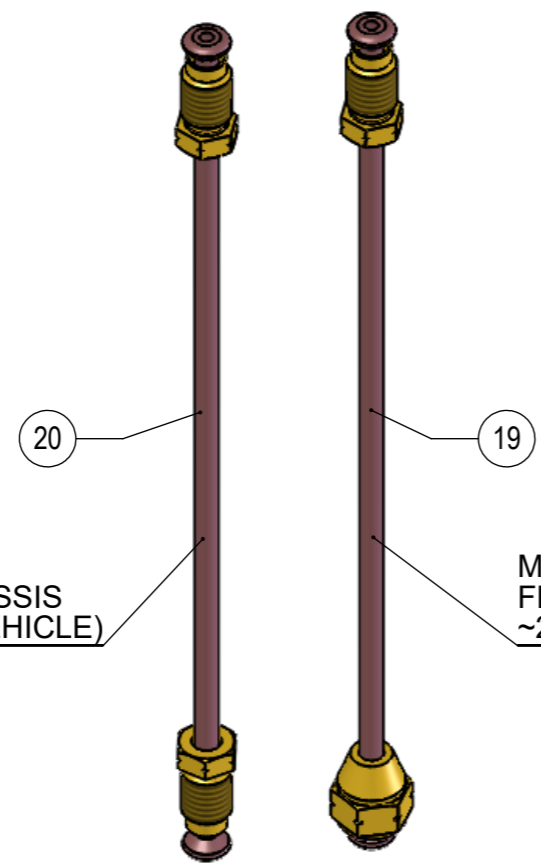
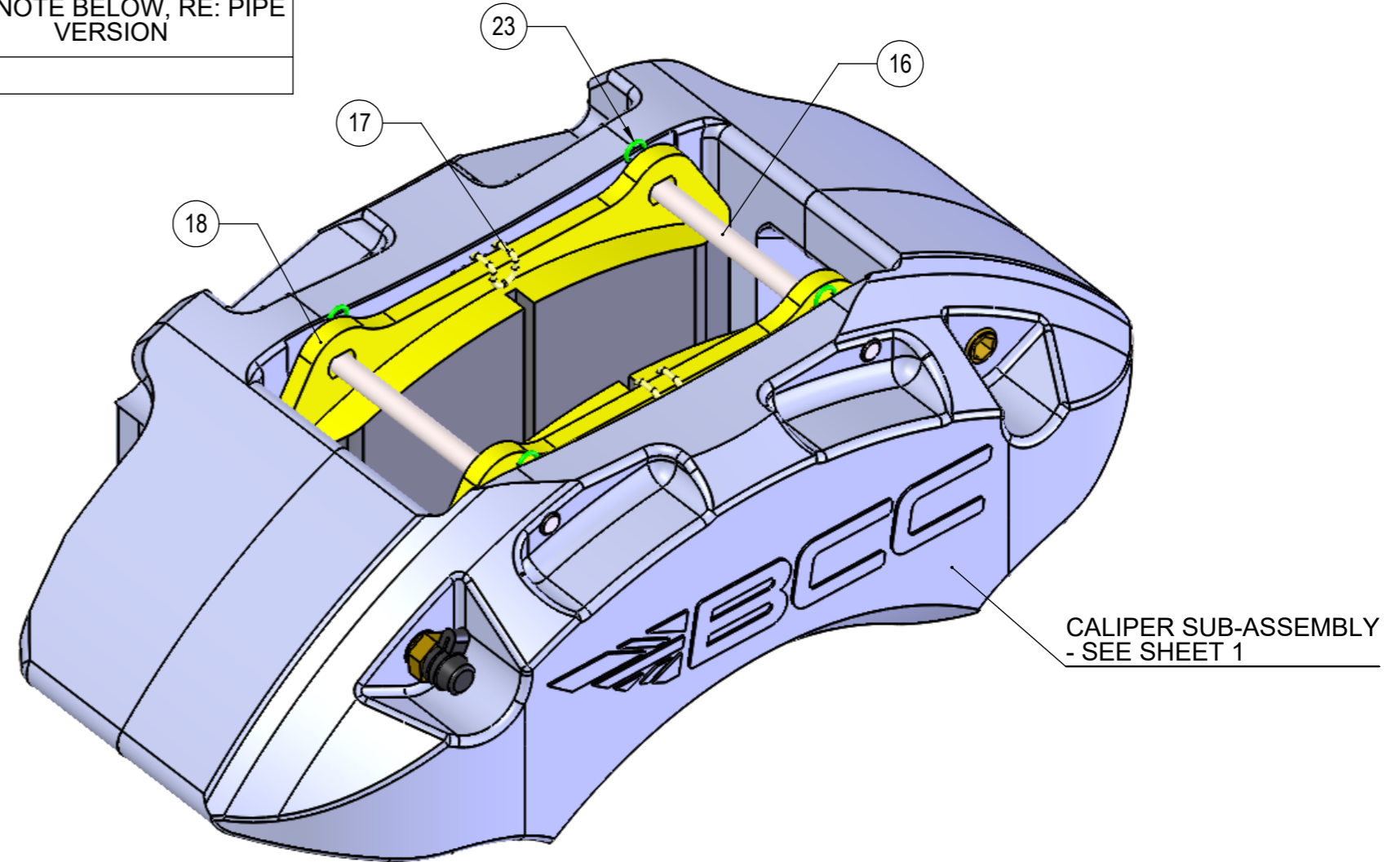

M-M, M10 PIPE ASSY.
(FROM ~2004 OR CHASSIS
4A638618 FOR ABS VEHICLE)

M-F, M10 PIPE ASSY.
FROM 1970'S UNTIL
~2004

CALIPER SUB-ASSEMBLY
- SEE SHEET 1

** UNLESS OTHERWISE SPECIFIED, ONLY ONE OF THESE PIPES TO BE SUPPLIED WITH EACH CALIPER AS PART OF THE STD' CALIPER KIT ASSY (TOTAL: 2 PIPES) DEPENDANT ON MODEL-YEAR VEHICLE: ESTABLISHED AT TIME OF CUSTOMER ORDER. END FITMENTS ARE M10.

SHEET 2

DIMENSIONS ARE IN MILLIMETERS. NO DECIMAL PLACE ± 0.50 ONE DECIMAL PLACE ± 0.25 TWO DECIMAL PLACES ± 0.10 ANGULAR DIMENSIONS : ± 0.25° BEND: ± 0.5° SURFACE FINISH : Ra1.6 UNLESS STATED OTHERWISE. CRITICAL DIMENSION				CUSTOMER: BCC	
DRAWN SM		SIGNATURE		DESIGN TYPE	
CHK'D SH		DATE 21/08/2020		SIMPLE . COMPLEX X	
APP'VD JG		DATE 16/03/21		HEAT TREATMENT: -	
MFG RA		DATE 19/03/21		MATERIAL: SEE BOM	
		DATE 18/03/21		FINISH: SEE BOM	
DEBUR AND BREAK SHARP EDGES				TITLE: FULL ASSEMBLY	
LOCATION: F:\Solidworks\BCC\BRAKES\ASSEMBLIES\BCC 0216 - ANGLESEY 16\				DWG NO. BCC 0216A	
				SCALE: .	
				REVISION: 2	



THIRD ANGLE PROJECTION
PROPRIETARY AND CONFIDENTIAL
THE INFORMATION CONTAINED IN THIS DRAWING IS THE SOLE PROPERTY OF BC Car Parts Ltd. ANY REPRODUCTION IN PART OR AS A WHOLE WITHOUT THE WRITTEN PERMISSION OF BC Car Parts Ltd IS PROHIBITED.

BCC A3L

A3

CALIPER ACCESSORIES

ITEM NO.	QTY.	PART NUMBER	DESCRIPTION
1	1 KIT	BCC 0190-USR NS DISC BCC 0190-USR OS DISC	ACCESSORY PART

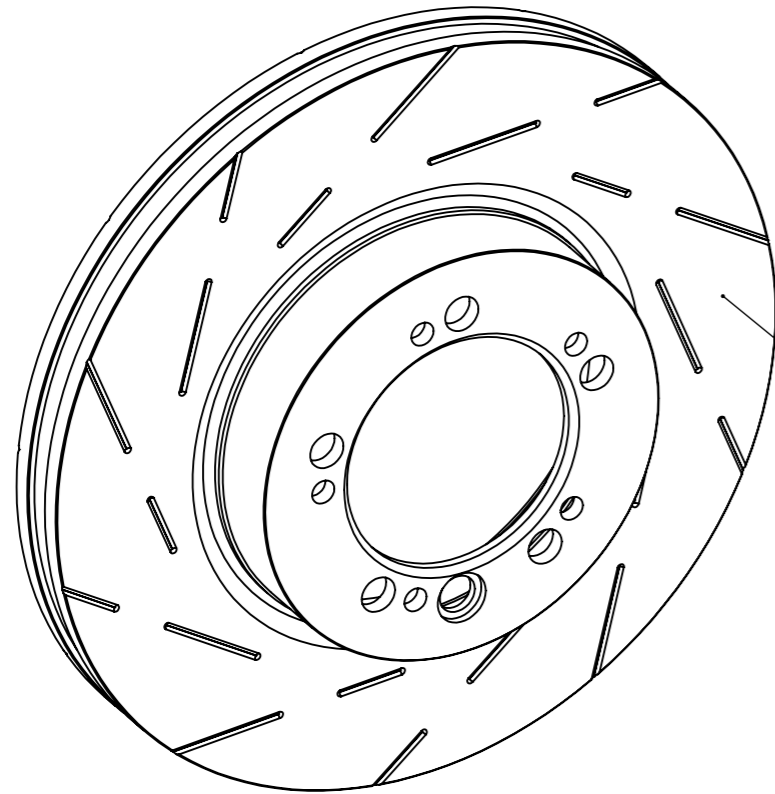

NEARSIDE DISC (RHD)
NOTE GROOVE PATTERN!

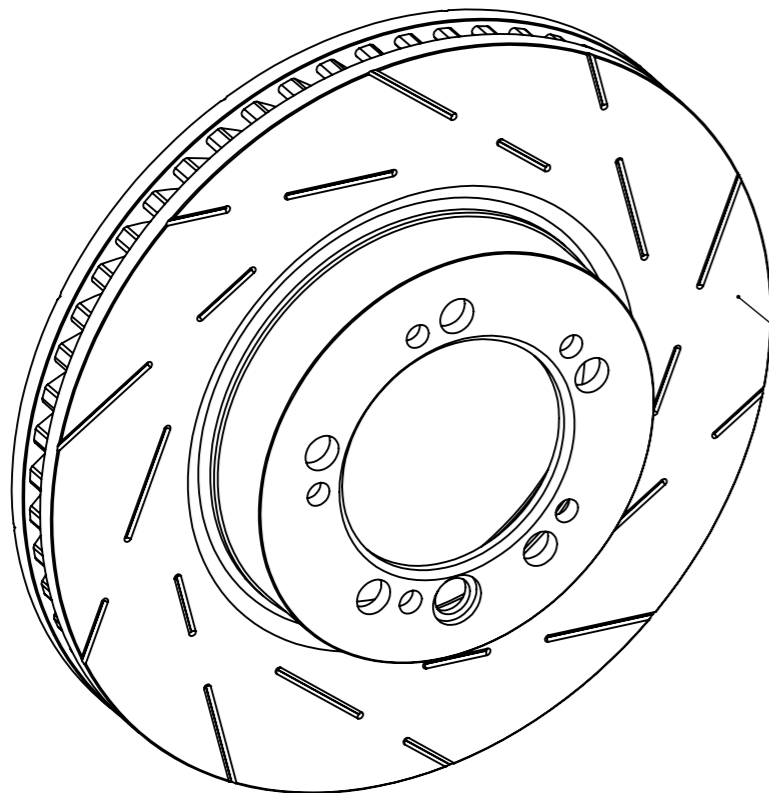

OFFSIDE DISC (RHD)
NOTE GROOVE PATTERN!

SHEET 3

DIMENSIONS ARE IN MILLIMETERS.
NO DECIMAL PLACE ± 0.50
ONE DECIMAL PLACE ± 0.25
TWO DECIMAL PLACES ± 0.10
ANGULAR DIMENSIONS : ± 0.25° BEND: ± 0.5°
SURFACE FINISH : Ra1.6 UNLESS STATED OTHERWISE.
CRITICAL DIMENSION



<http://www.britishclassiccarsparts.com>
[+44\(0\)1209 202800 info@bcc-parts.com](mailto:info@bcc-parts.com)

	NAME	SIGNATURE	DATE
DRAWN	SM		25/02/21
CHK'D	SH		25/02/21
APP'VD	JG		25/02/21
MFG	RA		25/02/21



THIRD ANGLE PROJECTION
PROPRIETARY AND CONFIDENTIAL
THE INFORMATION CONTAINED IN THIS DRAWING IS THE SOLE PROPERTY OF BC Car Parts Ltd. ANY REPRODUCTION IN PART OR AS A WHOLE WITHOUT THE WRITTEN PERMISSION OF BC Car Parts Ltd IS PROHIBITED.

LOCATION: F:\Solidworks\BCC\BRAKES\Brake Disks\BCC 0190-X1

CUSTOMER: BC Car Parts Ltd	
DESIGN TYPE	SIMPLE COMPLEX X
HEAT TREATMENT:	
MATERIAL: SEE BOM	FINISH: NATURAL
TITLE: ACCESSORY PARTS	
DWG NO. BCC 0216A	A3
SCALE: NTS	REVISION: 2

BCC A3L

CALIPER SERVICE KIT - BASIC

	ITEM NO.	QTY. PER CALIPER	QTY. PER AXLE	PART NUMBER	DESCRIPTION
SERVICE KIT: TBA	1	2	4	BCC 0188	BRAKE PAD PIN
	2	2	4	BCC 0163	BRAKE PAD SPRINGS
	3	0.5	1	DP41462R	BRAKE PAD
	4	4 \triangle	8	BCC 0246	1.2MM R-CLIP

** BRAKE PADS ARE SUPPLIED AS A BOX OF FOUR (2 PER CALIPER)

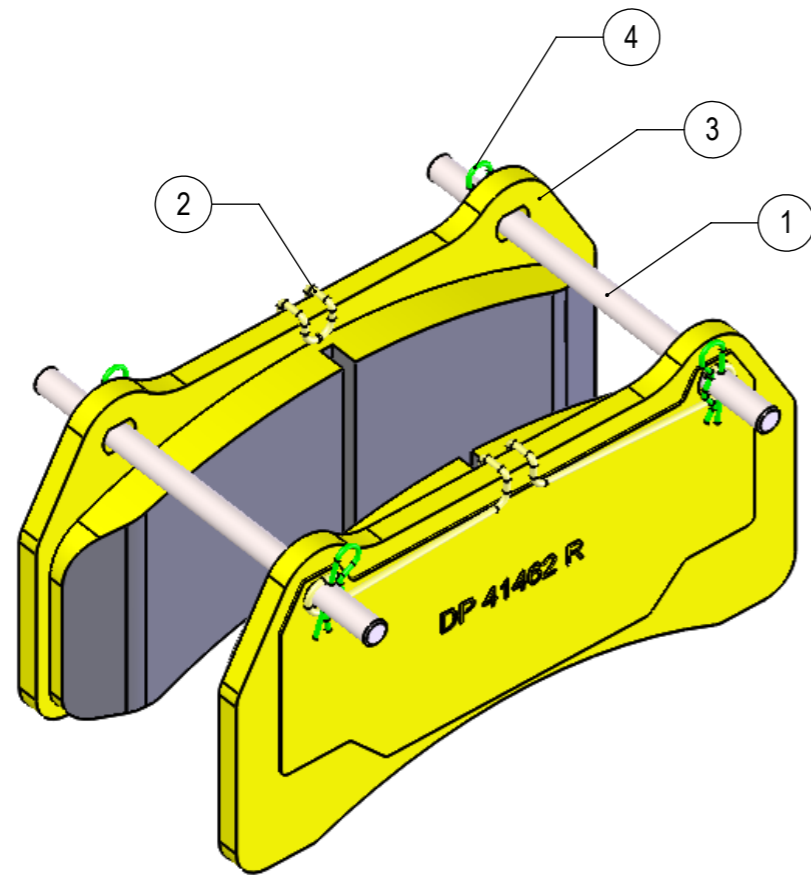

CALIPER SERVICE KIT - FULL

	ITEM NO.	QTY. PER CALIPER	QTY. PER AXLE	PART NUMBER	DESCRIPTION
SERVICE KIT BCC 0396	1	1	2	BCC 0088	M10x1 BLEED NIPPLE
	2	2	4	BCC 0139	INTERNAL BRIDGE SEAL
	3	2	4	BCC 0188	BRAKE PAD PIN
	4	1**	0	BCC 0086	Ø36 SEAL KIT *
	5	4	8	BCC 0085	Ø36 PISTON
	6	2	4	BCC 0084	Ø38 LR PISTON
	7	2	4	BCC 0163	BRAKE PAD SPRINGS
	8	1	2	BCC 0340	BLEED NIPPLE COVER
	9	0.5	1	DP41462R	BRAKE PAD
	10	2	4	BCC 0044	Ø38 SEAL KIT *
	11	4 \triangle	8	BCC 0246	1.2MM R-CLIP

* Ø36 SEAL KIT COMPRISES OF 4x FLUID AND 4x DUST SEAL.
 ** Ø38 SEAL KIT COMPRISES OF 2x FLUID AND 2x DUST SEAL.
 *** BRAKE PADS ARE SUPPLIED AS A BOX OF FOUR (2 PER CALIPER)

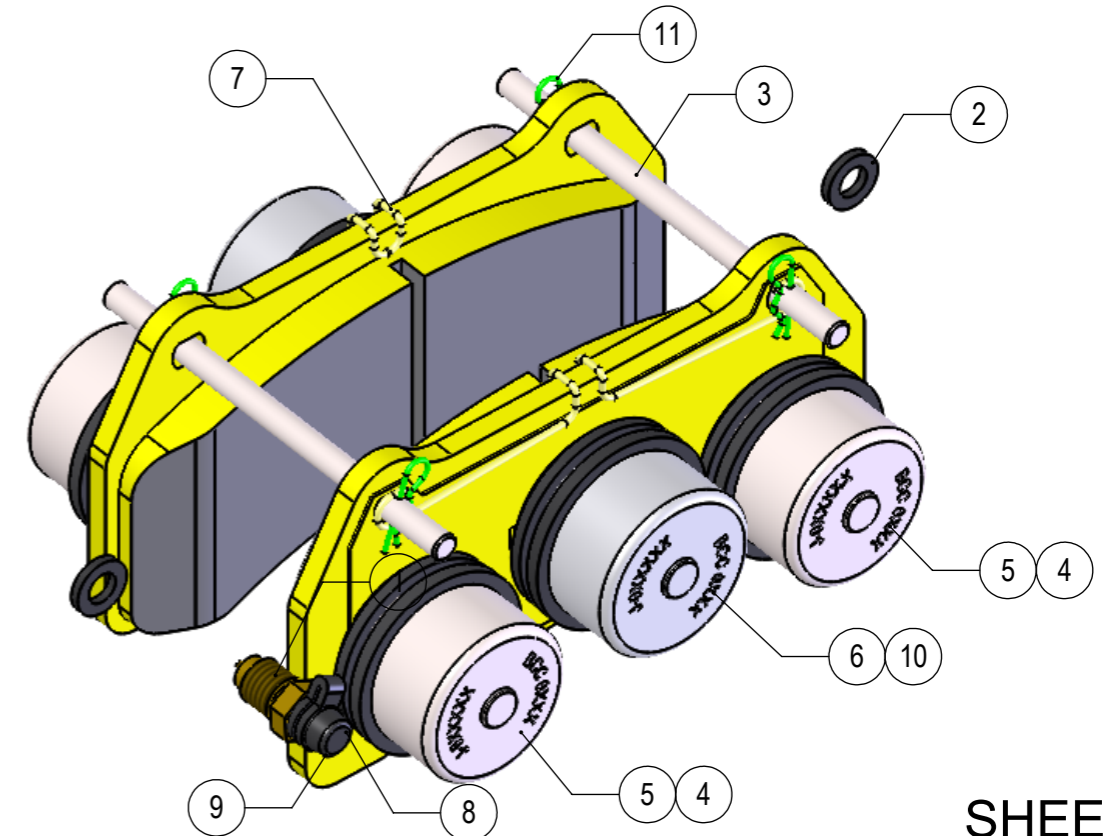

SHEET 4

DIMENSIONS ARE IN MILLIMETERS. NO DECIMAL PLACE ± 0.50 ONE DECIMAL PLACE ± 0.25 TWO DECIMAL PLACES ± 0.10 ANGULAR DIMENSIONS : ± 0.25° BEND: ± 0.5° SURFACE FINISH : Ra1.6 UNLESS STATED OTHERWISE. CRITICAL DIMENSION				CUSTOMER: BCC DESIGN TYPE: SIMPLE / COMPLEX X HEAT TREATMENT: - MATERIAL: SEE BOM FINISH: SEE BOM	
http://www.britishclassiccarsparts.com +44(0)1209 202800 info@bcc-parts.com				TITLE: SERVICE KITS DWG NO. BCC 0216A	
DEBUR AND BREAK SHARP EDGES				SCALE: . REVISION: 2	
LOCATION: F:\Solidworks\BCC\BRAKES\ASSEMBLIES\BCC 0216 - ANGLESEY 16\				A3	

BCC A3L

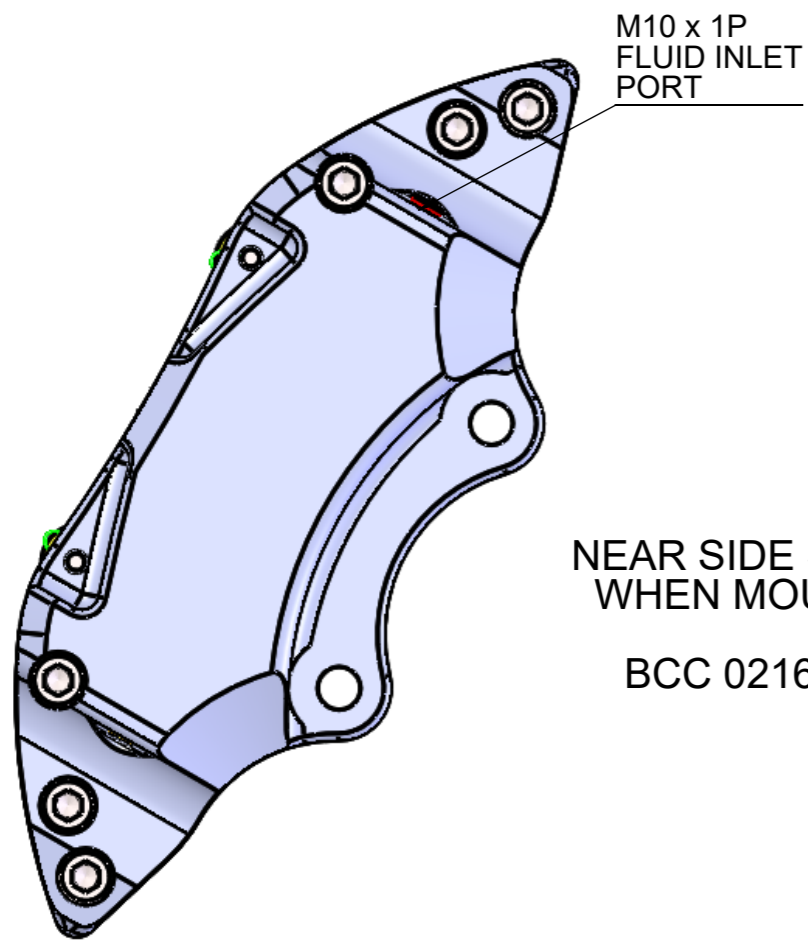

NEAR SIDE SHOWN
WHEN MOUNTED
BCC 0216A NS

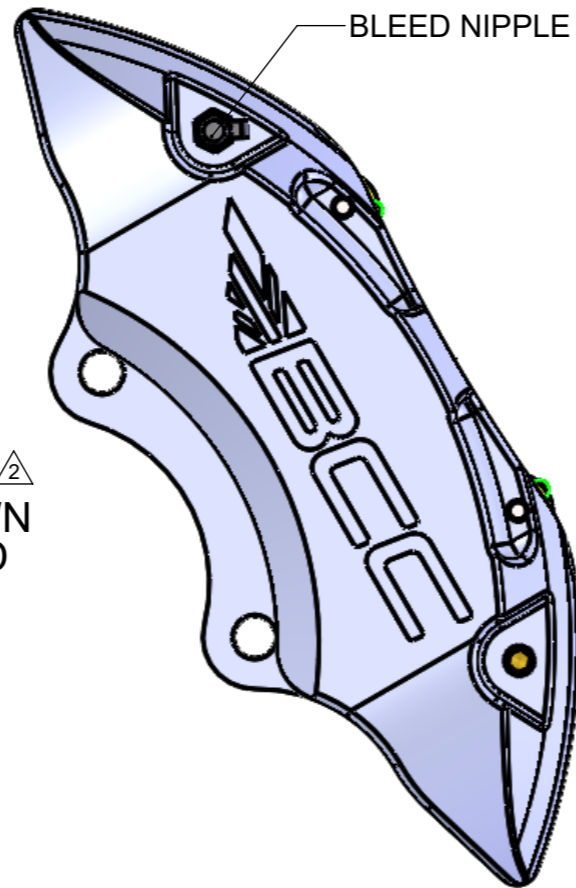

BLEED NIPPLE

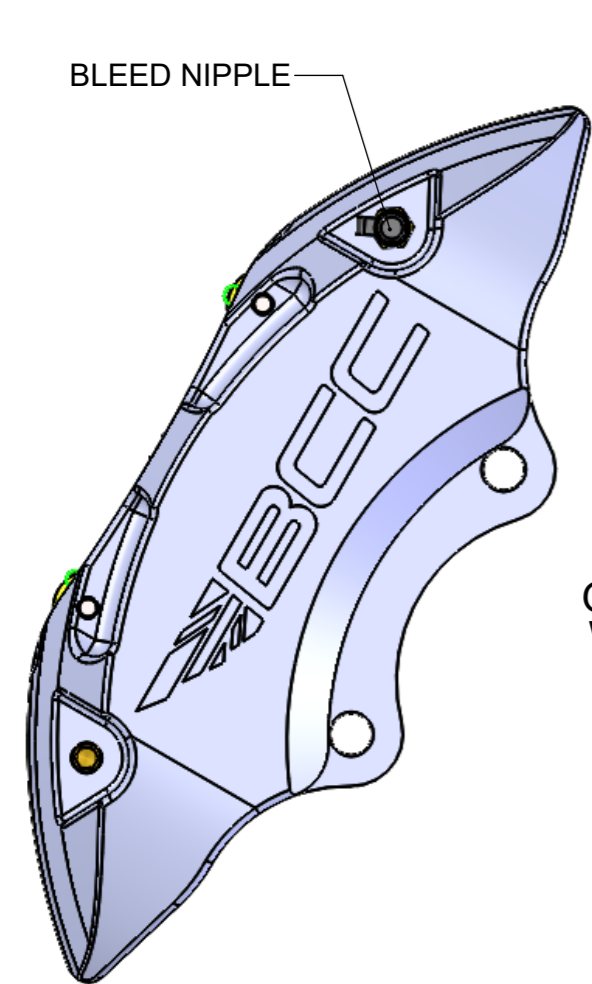

BLEED NIPPLE

OFF SIDE SHOWN
WHEN MOUNTED
BCC 0216A OS

M10 x 1P
FLUID INLET
PORT

DIMENSIONS ARE IN MILLIMETERS.
NO DECIMAL PLACE ± 0.50
ONE DECIMAL PLACE ± 0.25
TWO DECIMAL PLACES ± 0.10
ANGULAR DIMENSIONS : ± 0.25° BEND: ± 0.5°
SURFACE FINISH : Ra1.6 UNLESS STATED OTHERWISE.
CRITICAL DIMENSION



<http://www.britishclassiccarsparts.com>
[+44\(0\)1209202800info@bcc-parts.com](mailto:+44(0)1209202800info@bcc-parts.com)

	NAME	SIGNATURE	DATE
DRAWN	SM		21/08/2020
CHK'D	SH		16/03/21
APP'VD	JG		19/03/21
MFG	RA		18/03/21



THIRD ANGLE PROJECTION
PROPRIETARY AND CONFIDENTIAL
THE INFORMATION CONTAINED IN THIS DRAWING IS THE SOLE PROPERTY OF BC Car Parts Ltd. ANY REPRODUCTION IN PART OR AS A WHOLE WITHOUT THE WRITTEN PERMISSION OF BC Car Parts Ltd IS PROHIBITED.

LOCATION: F:\Solidworks\BCC\BRAKES\ASSEMBLIES\BCC 0216 - ANGLESEY 16\

CUSTOMER: BCC		HEAT TREATMENT: -	
DESIGN TYPE	SIMPLE COMPLEX X	FINISH: SEE BOM	
MATERIAL: SEE BOM		FINISH: SEE BOM	
TITLE: MOUNTING CONFIG'			
DWG NO. BCC 0216A		A3	
SCALE: .		REVISION: 2	

SHEET 5

BCC A3L