

Ideal for 1" copper and 1¼" NPT iron pipework

# MagnaClean®

## Professional 2XP

Hydronic heating filter for large residential systems  
Removes black iron oxide sludge

Iron oxide sludge is one of the main causes of boiler failures. *MagnaClean* filters extend the life of hydronic heating systems when used as part of **ADEY's Best Practice™** system process.



ADEY is the industry leader in hydronic heating system protection.

Visit [adeyusa.com](http://adeyusa.com) for information on a complete system to safeguard your investment, including **ADEY's Best Practice™** treatment products.

Our unique cleaning products are designed to clean and protect your hydronic heating system, ensuring it achieves maximum performance season after season.



Toll free: 844 378 0442 | Office: 412 406 8292 | Email: [info@adeyusa.com](mailto:info@adeyusa.com)  
[adeyusa.com](http://adeyusa.com)



M08615 LF2-01-02597



# MagnaClean<sup>®</sup> Professional 2XP

## X-Treme protection against black iron oxide and other debris

Today's high-performance circulators and boilers are bringing new levels of efficiency and cost-savings to homeowners. But they are uniquely vulnerable to a danger lurking in nearly every hydronic heating system – Magnetite, commonly known as black iron oxide. An unavoidable result of oxidation inside untreated systems, black iron oxide forms on the surface of pipes and components where it deposits into the system water as microscopic particles which combine to form a black sludge. Even in small quantities, these particles can potentially cause expensive damage. As sludge accumulates, system efficiency is dramatically reduced, and operating costs increase.

**MagnaClean Professional 2XP** features a unique, patented magnetic and non-magnetic filtration system that starts to work from the moment it is installed. Removing virtually all of the suspended iron oxide sludge that collects in all hydronic heating systems.

The easy-to-install *MagnaClean Professional 2XP* is a dedicated filter for larger systems that not only extends the operational life of the hydronic heating system, but also offers a host of other unique benefits...

### Installer benefits

- X-treme performance, large-capacity filter
- Rapid in-line installation, featuring in-line inlet and outlet ports with bi-directional flow
- Designed for larger heating systems (1" copper and 1¼" black iron pipes)
- Integral flow-diverters ensure 360° distribution for uniform flow around magnets, maximizing sludge capture
- Powerful permanent magnet
- Also captures non-magnetic debris
- Rotating filter connections allow customizable installation options
- Low-profile drain valve and built-in air vent for easier maintenance
- Tool-free valve connection, designed to prevent cross threading
- Improved high-performance seals and bore size for greater flow and reliability
- Bi-directional flow – either port can be designated as entry port
- Easy dosing of ADEY treatment products via canister
- Full-flow valves for minimal pressure drop



### Homeowner benefits

- Long-term system protection for peace of mind
- Reduced heating bills
- Reduced maintenance costs
- Greater efficiency means a warmer house
- Design allows for full flow at all times – meaning no loss of pressure and no loss of heat
- Extends system life
- Zero operating cost
- System magnet lasts a lifetime
- Reduced carbon emissions

### Quick and Easy Installation

*MagnaClean Professional 2XP* should be fitted on the return pipe to the boiler/circulator. Slip socket design allows quick, hassle-free, in-line fitting in minutes.

### Engineered for Maximum Effectiveness

The *MagnaClean Professional 2XP* has been engineered for optimum performance. Our unique, proprietary design maximizes first-pass capture of both magnetic and non-magnetic debris from the system by incorporating dual reverse flow zones. This 'ACTIVELY' traps any circulating debris and sludge, and provides ongoing protection – all while assuring continuous, full-flow operation, at all times. The result? Reduced utility costs and

## Technical specifications

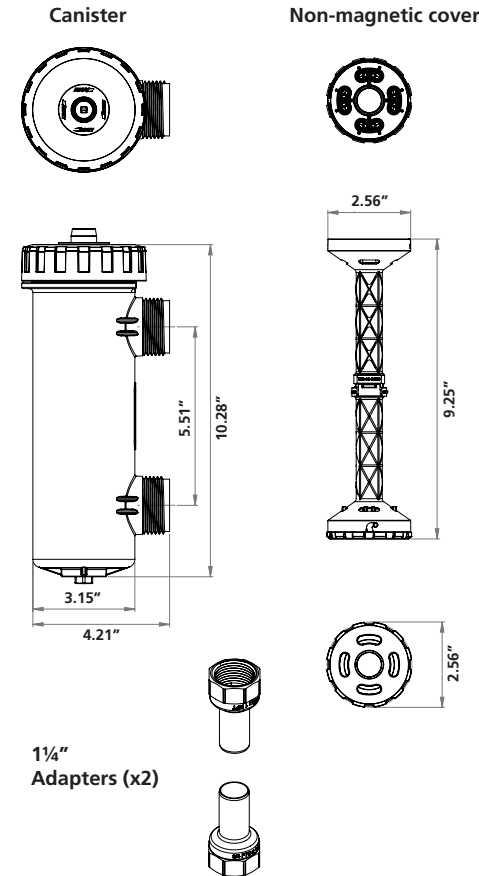

## Customizable installation

Unusual pipe angles? Limited space? No problem. The in-line design and 360° rotational valves of *MagnaClean Professional 2XP* allow installers to customize the job to fit almost any space – no matter how unusual – for maximum flexibility and minimum hassle.

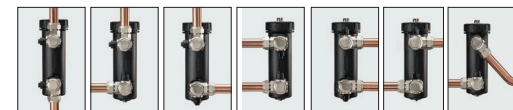

## How it works in just minutes!\*



Iron oxide sludge collects in a canister.



The *MagnaClean* filter is placed into the canister...



Within seconds, the water starts to clear as *MagnaClean* sets to work...



In just minutes, the *MagnaClean* filter traps almost all the sludge and debris, and the water is clear...



The *MagnaClean* filter is removed for easy, rinse-down cleaning.

\*The images above show how a *MagnaClean* filter removes iron oxide sludge from a hydronic heating system illustrated using a clear demonstration canister.

For more information or to see this step by step demonstration, visit

[adeyusa.com](http://adeyusa.com)

No installation is complete without *MagnaClean Professional 2XP*. Iron oxide sludge presents real problems... problems that can be avoided completely by the quick, easy, and cost-efficient installation of *MagnaClean Professional 2XP*.

Kick-start the efficiency of *MagnaClean Professional 2XP* by using *MagnaCleanse* to flush the system before installation. Visit [adeyusa.com](http://adeyusa.com) for more information on this and other **ADEY Best Practice™** solutions.