



TwinFresh Expert RA1-50-2 ENERGY RECOVERY VENTILATORS

**PRODUCT
SPECIFICATIONS**

**TECHNICAL
DATA**



DESCRIPTION

TwinFresh Expert RA1-50-2 designed to ensure filtration and supply of fresh air into the room as well as exhaust of stale air with energy regeneration. No freezing and condensation during operation.
Efficient supply and exhaust single-room ventilation air flow up to 30 CFM.

DIMENSIONS

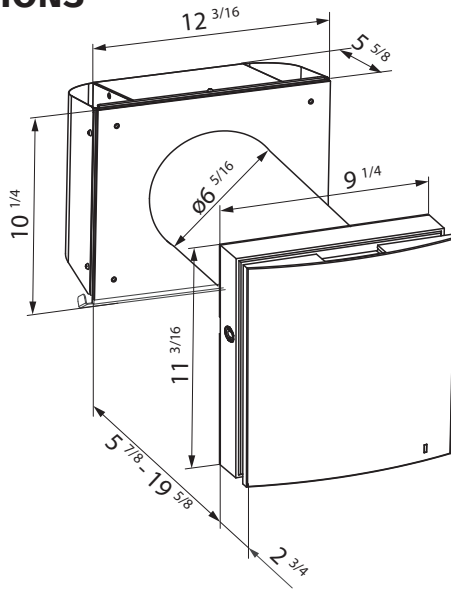

KEY FEATURES:

- Unique Single Room Energy Recovery Ventilator.
- One TwinFresh Expert unit in ventilation mode can serve rooms up to 500 sq. ft.*
- Communication between several ventilators for coordinated operation.
- High-tech ceramic energy regenerator with max. heat recovery efficiency up to 93 %.
- Built-in Humidity sensor, Timer and Weekly Scheduler.
- Automatic air shutters.
- MERV 5 filters (optionally MERV 14 filter).
- Antibacterial treatment of ERV core and filters.
- Easy installation and maintenance.

**In accordance with ANSI/ASHRAE Standard 62.2-2016*

MOTOR

DC motor with outstanding low energy demand from 3.61 W. The fan is powered by safe voltage 12 V. The motor has integrated overheating protection and ball bearings for long service life.

PERFORMANCE

Speed	1	2	3
Voltage / 50 (60) Hz [V]	1-100-240		
Power consumption [W]	3.61	4.15	5.20
Current consumption [A]	0.025	0.030	0.039
Air flow in ventilation mode [CFM]	9	18	30
Air flow in regeneration mode [CFM]	4	9	15
RPM	800	1300	1900
Sound pressure level @ 3 ft [Sones]	0.6	1.0	1.2
Sound pressure level @ 10 ft [Sones]	0.3	0.5	0.6
Outdoor sound pressure attenuation [Sones]	2.5		
Transported air temperature [°F]	from +5 up to +104		
Regeneration efficiency [%]	max. 93		
Regenerator type	Ceramic		
Filter	MERV 5 (option: MERV 14)		
Ingress protection	IP24		

MODEL	QUANTITY	COMMENTS	PROJECT
			location:
			architect:
			engineer:
			contractor:
			submitted by:

Tel: 888-640-0925 Sales@ventsus.com
 513-348-3853 VentsUS.com
 Fax: 513-268-4597 11013 Kenwood Road,
 Cincinnati, Ohio 45242

