

ST 200

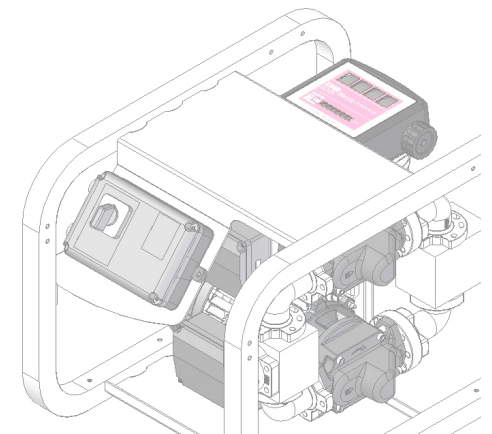

LAY-OUT product

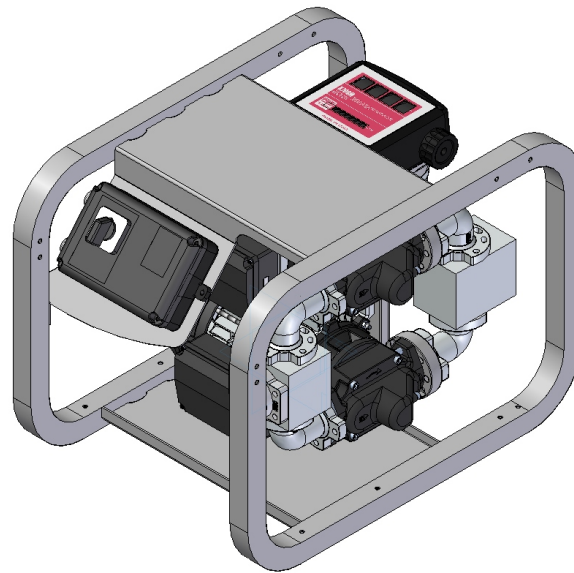
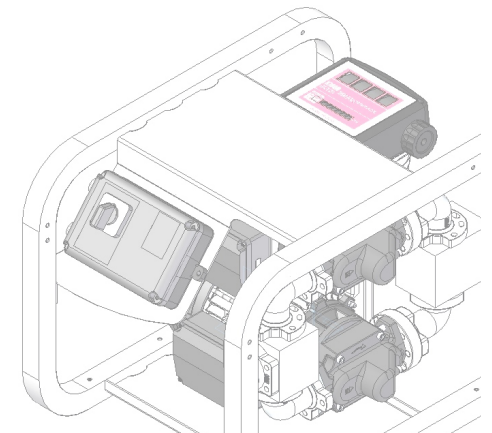
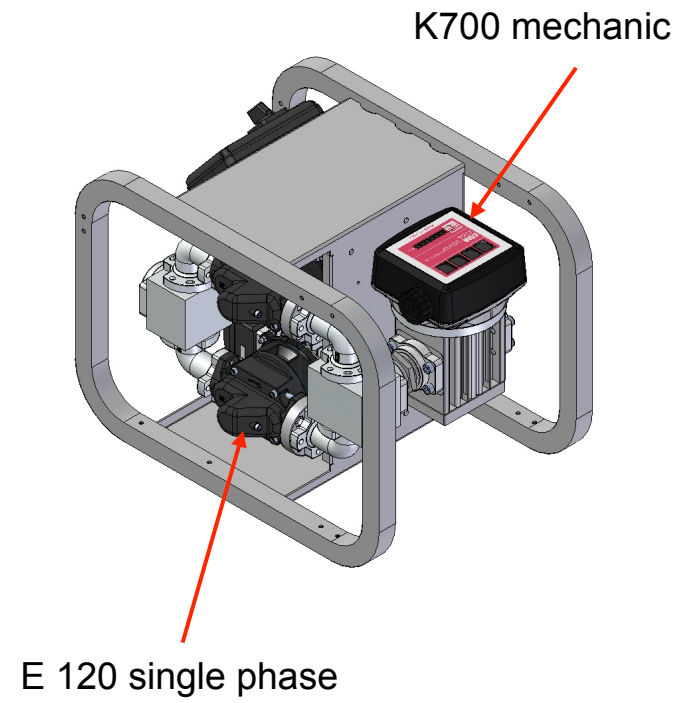
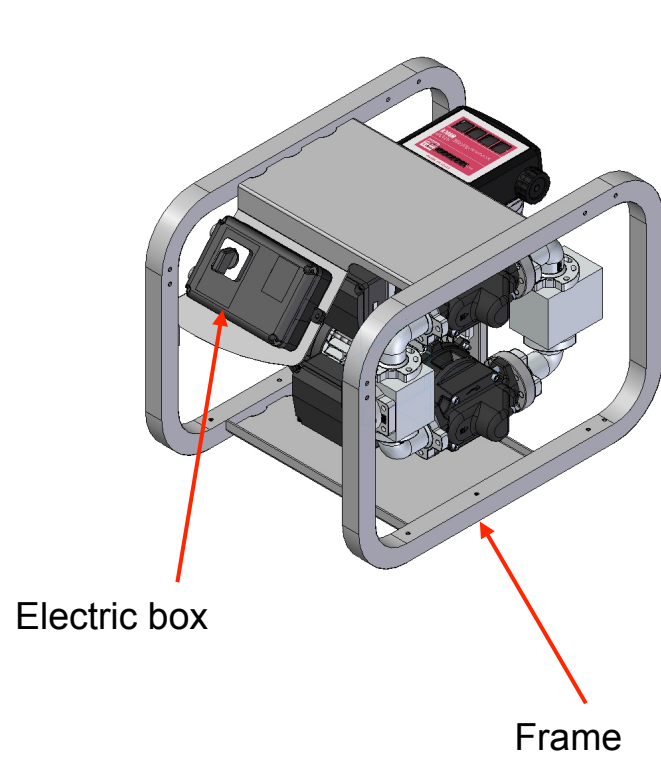

COMPOSITION OF THE PRODUCT

- Painted steel frame made with square pipe 25 mm
- 2 E 120 single phase pump in parallel
- Electrical box with single switch
- Inlet / Outlet da 1" 1/2

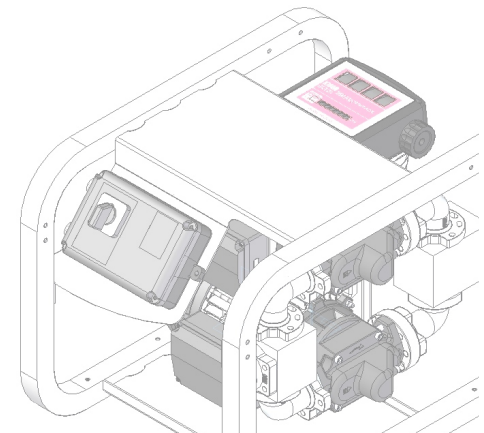

OBSTRUCTION

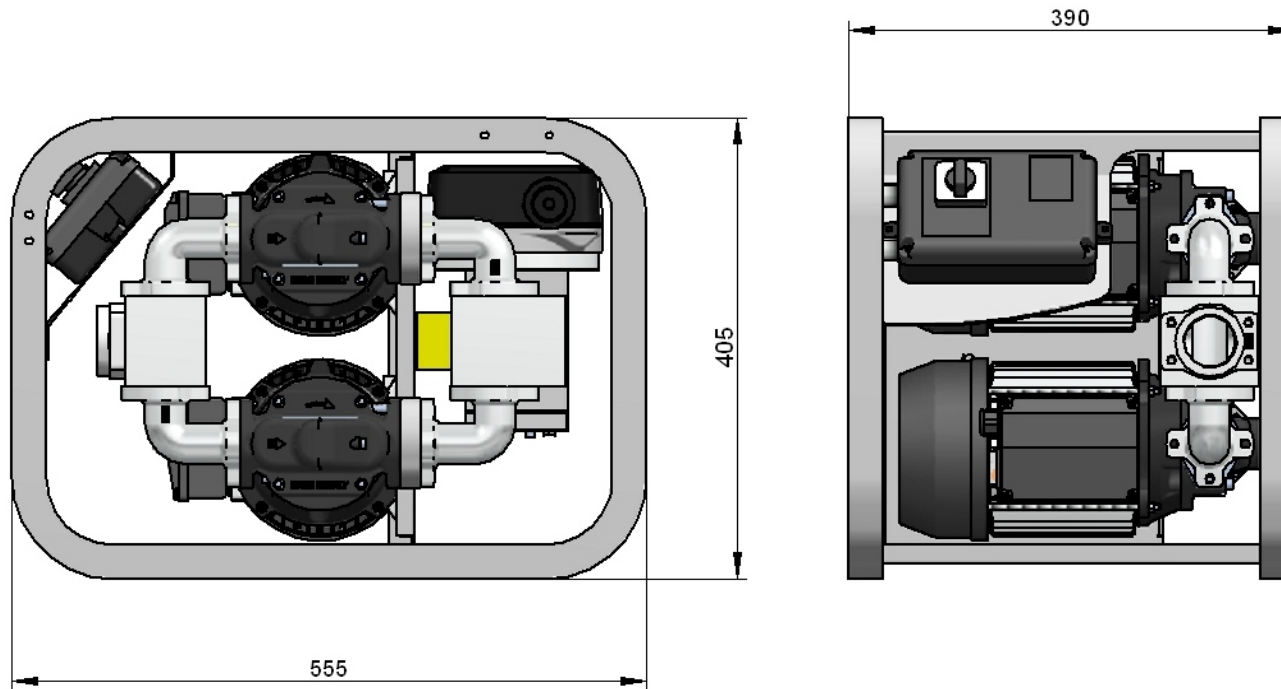

Estimated weight 50 Kg

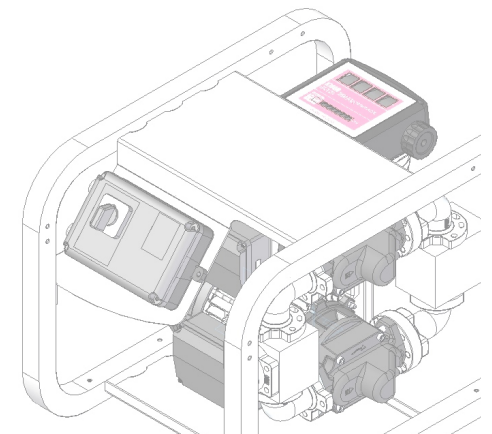

PERFORMANCES

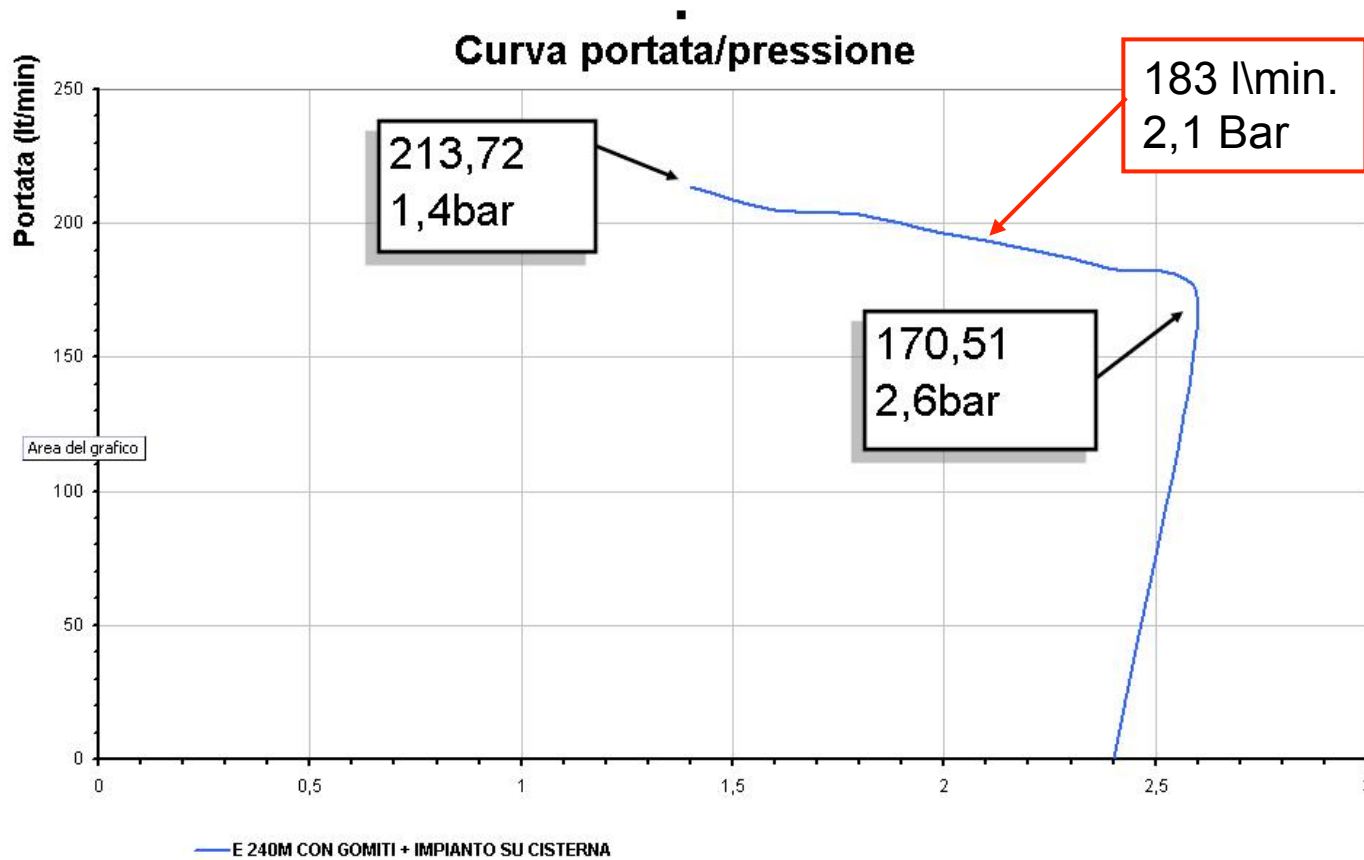

INSTALLATION “TYPE” 10m SUCTION HOSE 1 ½”.; 20m delivery hose 1 ½”.; meter K700; Nozzle automatic Pa280

