

**IT**    **AVVOLGITUBO AUTOMATICI**  
MANUALE DI USO E MANUTENZIONE

**EN**    **AUTOMATIC HOSE REELS**  
USE AND MAINTENANCE MANUAL

**FR**    **ENROULEURS AUTOMATIQUES**  
NOTICE D'UTILISATION ET D'ENTRETIEN

**DE**    **AUTOMATISCHE SCHLAUCHAUFRÖLLER**  
GEBRAUCHSANWEISUNG

**ES**    **ENROLLADORES AUTOMÁTICOS**  
MANUAL DE USO Y MANTENIMIENTO

**PT**    **ENROLADORES AUTOMÁTICOS**  
MANUAL DE UTILIZAÇÃO E MANUTENÇÃO

AIR  
WATER  
OIL  
GREASE  
ANTI-FREEZE  
WINDSHIELD

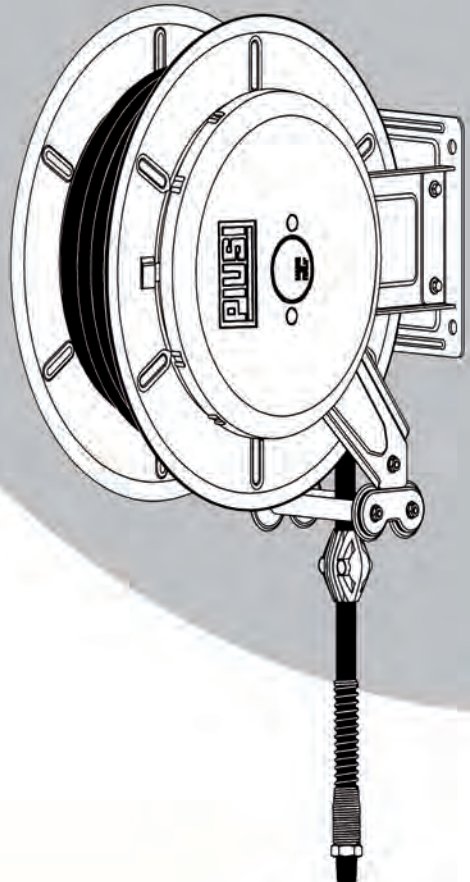

*Fluid Handling Innovation*

M0324 ML rev.01

**INDICE DEGLI ARGOMENTI**

1	INFORMAZIONI GENERALI.....	pag. 4
2	GARANZIA.....	pag. 4
3	DESCRIZIONE.....	pag. 4
4	FUNZIONAMENTO.....	pag. 4
5	USO PREVISTO DELLA MACCHINA.....	pag. 4
6	TARGATURA E DATI IDENTIFICATIVI.....	pag. 5
7	MONTAGGIO DEL TUBO.....	pag. 5
8	INSTALLAZIONE.....	pag. 6

**INDEX OF SUBJECT MATTERS**

1	GENERAL RULES APPLIED.....	page 10
2	WARRANTY.....	page 10
3	DESCRIPTION.....	page 10
4	OPERATION.....	page 10
5	INTENDED USE OF THE MACHINE.....	page 10
6	MARKING AND IDENTIFICATION.....	page 11
7	MOUNTING OF THE HOSE.....	page 11
8	INSTALLATION.....	page 12

**INDEX DES ARGUMENTS**

1	NORMES GENERALES APPLIQUEES.....	page 16
2	GARANTIE.....	page 16
3	DESCRIPTION.....	page 16
4	FONCTIONNEMENT.....	page 16
5	UTILISATION PRÉVUE DE LA MACHINE.....	page 16
6	ÉTIQUETAGE ET IDENTITÉ.....	page 17
7	MONTAGE DU TUYAU.....	page 17
8	INSTALLATION.....	page 18

**INHALTSVERZEICHNIS**

1	ALLGEMEINE ANGEWENDETE BESTIMMUNGEN.....	seite 22
2	GARANTIE.....	seite 22
3	BESCHREIBUNG.....	seite 22
4	BETRIEB.....	seite 22
5	VERWENDUNGSZWECK DER MASCHINE.....	seite 22
6	SCHILD UND IDENTIFIZIERUNGSANGABEN.....	seite 23
7	MONTAGE DES SCHLAUCHES.....	seite 23
8	INSTALLATION.....	seite 24

**INDICE DE CONTENIDOS**

1	NORMAS GENERALES APLICADAS.....	pag. 28
2	GARANTÍA.....	pag. 28
3	DESCRIPCIÓN.....	pag. 28
4	FUNCIONAMIENTO.....	pag. 28
5	UTILIZACIÓN PREVISTA DE LA MÁQUINA.....	pag. 28
6	ETIQUETADO E IDENTIFICACIÓN DE DATOS.....	pag. 29
7	MONTAJE DE LA MANGUERA.....	pag. 29
8	INSTALACION.....	pag. 30

**ÍNDICE DOS ASSUNTOS**

1	INFORMAÇÕES GERAIS.....	pag. 34
2	GARANTIA.....	pag. 34
3	DESCRIÇÃO.....	pag. 34
4	FUNCIONAMENTO.....	pag. 34
5	USO PREVISTO DA MÁQUINA.....	pag. 34
6	PLACA E DADOS IDENTIFICATIVOS.....	pag. 35
7	MONTAGEM DO TUBO.....	pag. 35
8	INSTALAÇÃO.....	pag. 36

---

9	ALLACCIAMENTO.....	pag. 6
10	MANUTENZIONE.....	pag. 7
11	SOSTITUZIONE DEL TUBO.....	pag. 7
12	SOSTITUZIONE DELLA MOLLA.....	pag. 8
13	SMALTIMENTO MATERIALE INQUINANTE.....	pag. 9
14	DICHIARAZIONE DI CONFORMITA'.....	pag. 9
15	DATI TECNICI.....	pag. 40

---

9	LINK.....	page 12
10	MAINTENANCE.....	page 13
11	REPLACEMENT OF THE HOSE.....	page 13
12	REPLACEMENT OF THE SPRING.....	page 14
13	DISPOSING OF CONTAMINATED MATERIALS.....	page 15
14	DECLARATION OF CONFORMITY.....	page 15
15	TECHNICAL DATA.....	page 40

---

9	BRANCHEMENT.....	page 18
10	ENTRETIEN.....	page 19
11	REPLACEMENT DU TUYAU.....	page 19
12	REPLACEMENT DU RESSORT.....	page 20
13	ELIMINATION DU MATERIEL POLLUE.....	page 21
14	DECLARATION DE CONFORMITE.....	page 21
15	FICHES TECHNIQUES.....	page 40

---

9	ANSCHLUSS.....	seite 24
10	WARTUNG.....	seite 25
11	AUSWECHSLUNG DES SCHLAUCHES.....	seite 25
12	AUSWECHSLUNG DER FEDER.....	seite 26
13	ENTSORGUNG VON VERSEUCHTEM MATERIAL.....	seite 27
14	CE KONFORMITATSERKLARUNG.....	seite 27
15	TECHNISCHE DATEN.....	page 40

---

9	CONEXION.....	pag. 30
10	MANTENIMIENTO.....	pag. 31
11	SOSTITUCION DE LA MANGUERA.....	pag. 31
12	SOSTITUCION DEL MUELLE.....	pag. 32
13	ELIMINACION DEL MATERIAL CONTAMINANTE.....	pag. 33
14	DECLARACION DE CONFORMIDAD CE.....	pag. 33
15	DATOS TÉCNICOS.....	pag. 40

---

9	LIGAÇÃO.....	pag. 36
10	MANUTENÇÃO.....	pag. 37
11	SUBSTITUIÇÃO DO TUBO.....	pag. 37
12	SUBSTITUIÇÃO DA MOLA.....	pag. 38
13	ELIMINAÇÃO DO MATERIAL POLUENTE.....	pag. 39
14	DECLARAÇÃO DE CONFORMIDADE.....	pag. 39
15	DADOS TÉCNICOS.....	pag. 40

## 1 - GENERAL RULES APPLIED

This manual is giving information about a correct assembly, use and maintenance of the hose reels in order to prevent accidents.

The hose reel has been planned in conformity to the present EEC rules.

This manual has been drafted according to the following norms:

10653 : 2003 - Technical documentation - Quality of the product technical documentation

10893 : 2000 - Product technical documentation - instructions for use - Sections and order of the content.

## 2 - WARRANTY

The equipment is guaranteed for a period of 18 months from date of purchase and must be used in accordance with the instructions contained in this manual. Warranty does not cover all parts which are faulty after incorrect use, incorrect installation or maintenance, maintenance carried out by unauthorized personnel, transport damages, or for circumstances not concerning manufacturing defects. The manufacturer disclaims any responsibility for any damage, that may directly or indirectly, derive to persons or property in consequence to the not observed requirements specified in this instruction manual and especially the warnings regarding installation, use and maintenance.

## 3 - DESCRIPTION

The hose reels models are made of hot galvanized moulded steel and painted with electrostatic polyester powder system in order to guarantee a long life of the product.

The hose rolling is done automatically by a spring made of high quality iron, incorporated in the drum. The stop can be done at any desired length, through an automatic locking device.

**The hose reels supplied without hose are provided with the unloaded spring. Follow the instructions described at the chapter "HOSE ASSEMBLY".**

## 4 - OPERATION

The automatic device to stop the hose is working on an area corresponding to 1/3 turn of the drum.

For releasing the hose, put a light traction on it.



**It is important always to keep the hose back when you rewind it, in order to avoid damages to the machine, injuries to people or to surrounding things.**

## 5 - INTENDED USE OF THE MACHINE

The hose reels of the painted series are suitable for distributing compressed air, oil, grease, water and anti-freeze/windshield.

**All the hose reels have to be used only for distributing fluids, at the pressures and temperatures indicated on the schedule at the end of the manual.** Every hose reel code is corresponding to a different kind of fluid. **It is forbidden to use the machine for any other kind of fluid.**

We decline any responsibility for anomalies or dangers which could arise by an hose assembly with characteristics and uses different from the ones described herein.

- Avoid to get on the machine or to lay any kind of material on it.
- Check periodically the correct operation of the hose reel, and control that the couplers are well locked and there are no fluid losses.
- Close the feeding of fluid at the shift end to avoid damages during non-working hours.
- **Use of the hose reel is not permitted in potential explosive environments (ATEX).**

## 6 - MARKING AND IDENTIFICATION

PIUSI

CERTIFIED COMPANY  
UNI EN ISO 9001

**MADE IN ITALY**

MEMBER  
**PEI**  
OFFICIAL EQUIPMENT ITALY

CE

PIUSI S.p.a.  
46029 Suzzara  
(MN) ITALY

HA60151200

2014

**OIL HOSE REEL 1/2" - 15 m**

WEIGHT: 19 Kg Pmax: 60 bar

LOT NUMBER: 4500098802/10

**ATTENTION: READ MANUAL**

We affix the CE marking as the manufacturer of this equipment.

On the equipment is securely attached a tag with curing adhesive system on which, in addition to the name of the manufacturer and the symbol "CE", all necessary information for good identification of the machine are indicated (model, duty, year of construction, weight, etc.).

ZEN

## 7 - MOUNTING OF THE HOSE (Models without hose)

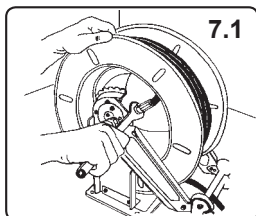

**The hose reels without hose are supplied with the unloaded spring.**

Use a hose with dimension and pressure characteristics suitable for use according to the hose reel model.

Normally, the hoses must be connected Female Straight Gas, except for those to be used for the following fluids which must have these characteristics:

- Oil (3/4"): EN857 1SC hose with fitting F.90° 3/4"G.
- Oil (1"): EN857 1SC hose with fitting F.S.1"G.

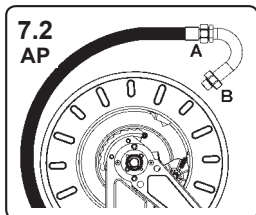

7.0) Fix the hose reel to the bench and remove plastic protection.

7.1) For models with hose <math>< 5/8''</math>. Put the hose between the guide rollers, connect it to the fitting which is inside the drum and tighten by the suitable wrench.

7.2) Models High Pressure 1"(HP): connect the hose (A) to the curve, tightening with the suitable wrench. Tighten the nut (B) on the connection of the drum.

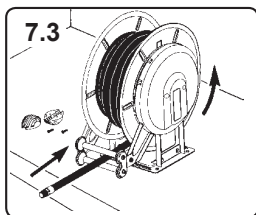

7.3) Mount the lateral protection and rotate manually the drum in order to rewind completely the hose.

7.4) Spring Preload: hold the hose-end and rotate the drum in the opposite direction for a few laps, refer to the tables p.40

7.5) Insert the hose-end between the guide rollers and put the hose rubber stopper at the desired length.

7.6) Unwind the hose and rewind it completely, to check if the hose reel works properly.

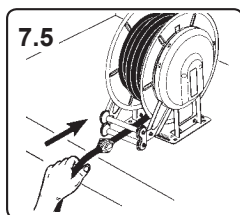
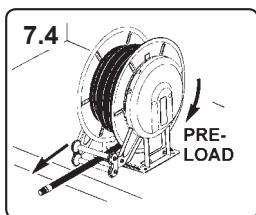

**⚠ WARNING!**

**WARNING! DO NOT PUT HANDS OR ANY OTHER THING INSIDE THE DRUM!**

## 8 - INSTALLATION



**IMPORTANT!** Any installation operation shall be carried out by a suitably trained staff, following carefully the information given in this manual.

Check the packaging at the reception of the goods and store only at a dry place. Verify that the device hasn't been damaged during transport or storage operations. Make sure you receive all the components. Ask the manufacturer for any possible missing component.

**The hose reel has to be wall mounted at a minimum height of the floor of 2.50 m in order to prevent accidents during work operations.** Considering the hose reel weight and dimensions, his movement requires the use of lifter devices. In particular cases it is possible to mount it on the floor or on other machines as accessory, only if complete with a fixed support. The hose-guide arms can be fixed in three different positions according to the hose reel installation (see pictures A-B-C p.41). **IMPORTANT!** Models with hose 1" for oil only allow the installation on positions A - B.

Mount the hose reel in fixed position or with revolving stand (optional) on stiff and consistent walls using 4 dowels of 10 mm diameter. (see drawing p.41)

**WARNING! The manufacturer declines any responsibility for injuries to people or damages to things caused by a wrong assembly of the hose reel.**

## 9 - LINK

**Always connect the hose reel to the line by the couplers and the flexible hose (A) suitable for this use, above all in case of high pressure and temperature.**

**To avoid consequent loss of fluid tighten the fittings using appropriate keys, keep back the swivel joints to avoid damaging them.**

According to the rules, put a ball-tap on the feeding line of the hose reels in order to make the maintenance operations easier. The said ball-tap can be used as a safety valve for dangerous situations.

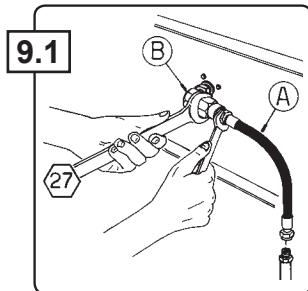

### 9.1) Air, Water, Oil, Anti-freeze/Winshield:

When you lock the fitting, hold the swivel joint by the 27 wrench (B) in order not to damage it. Thus it is possible to avoid consequent losses of fluid from the inside seal (hose reels for high pressure).

Tighten the swivel joint on the shaft, fit the inlet hose and the lateral cover.

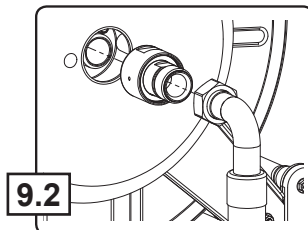

### 9.2) Oil (3/4"-1"):

Tighten the swivel joint on the shaft, fit the lateral cover and tighten the elbow 90° on the swivel joint.

## 10 - MAINTENANCE



**IMPORTANT:** Any maintenance operation shall be carried out by a suitably trained staff, following carefully the information given in this manual. Ensure that there is no tension in the spring before starting any operations inside the hose reel.

Always close the feeding of fluid to the machine before carrying out any maintenance on it. Replace the flexible hose as soon as it shows any sign of wear and tear or of deterioration due to the different conditions of the labour environment. We advise you to replace it every year in case it is used for a few hours a week.

Replace the seal inside the revolving joint in case of losses due to wear and tear. Any replacement of hose reel parts has to be done using original spare parts.

We advise you to contact the manufacturer for any possible anomaly and before replacing any part. After every maintenance operation, put again the eventual supports.

NE

## 11 - REPLACEMENT OF THE HOSE

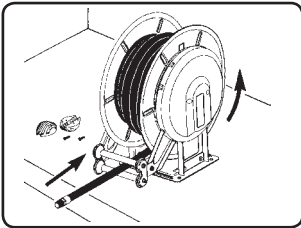

11.1



**WARNING!** For safety reasons, operations of hose replacement must be carried out at the bench.

Replace the hose with another one of the same dimensions and characteristics.

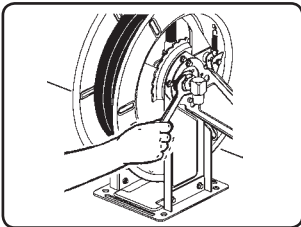

11.2

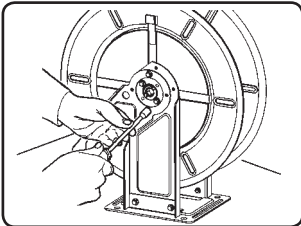

11.3

11.1) Remove the hose rubber stopper and release the hose slowly until the spring is completely unloaded.

11.2) Loosen the swivel joint.

11.3) Loosen the two screws of the spring linkage shaft by a 10 wrench.

11.4) Disassemble the opening on the spring side and unwind completely the hose from the drum.

11.5) Take out the drum, unscrew the internal fitting with the suitable wrench and mount the new hose.

11.6) Assemble again the hose reel, by following the above steps in reverse order. If that is the case, grease the supports and the ratchet hook.

11.7) Go on as indicated at point 7.3 of the chapter: Mounting of the hose.

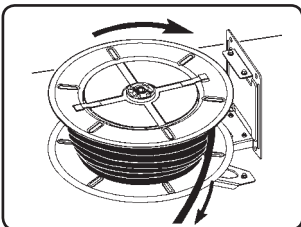

11.4

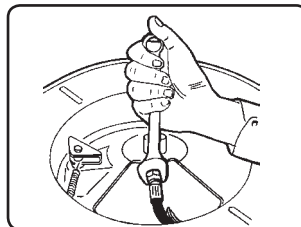

11.5

## 12 - REPLACEMENT OF THE SPRING

The spring which allows to rewind the hose is placed inside a proper housing centre which is joint to the drum.



**WARNING!** The disassembly of the spring is only permitted to the staff authorized and suitably trained by the manufacturer. Handle with the greatest care the spring; serious accidents might occur.

12.1) Make sure that the rewinding system is totally unloaded and that the drum is free (see point 11.1)

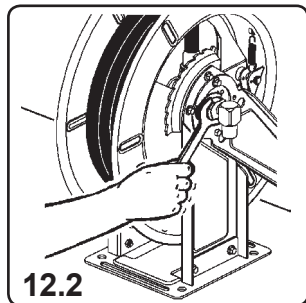
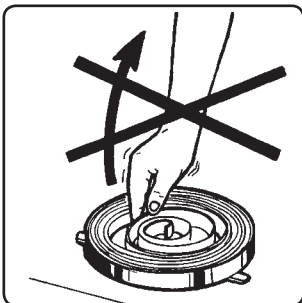

12.2) Loosen the swivel joint

12.3) Loosen the two screws of the spring linkage shaft by a 10 mm wrench (see point 11.3).

12.4) Disassemble the opening on the spring side by a 10 mm wrench and take out the drum.

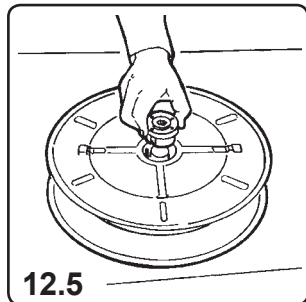
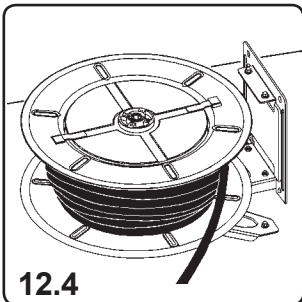

12.5) Take out the shaft from the spring housing.

12.6) Lift the tangs on the drum by a screwdriver and rotate the spring housing centre in order to release it from the drum.

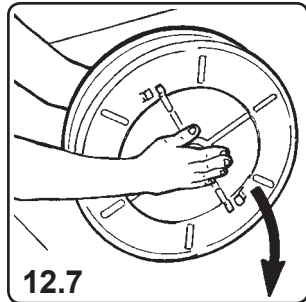
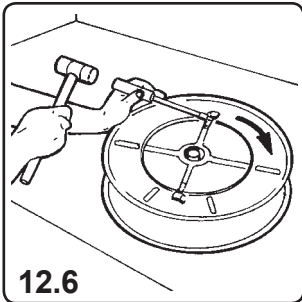

12.7) Turn upside down the drum and take out the spring housing centre paying the greatest care so that the spring does not go out of it.

12.8) Insert and hook the shaft into the new spring housing centre. Lubricate the spring and the shaft.

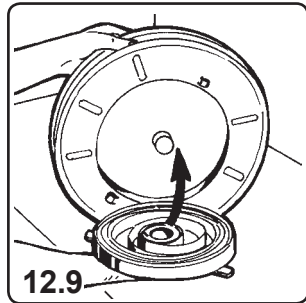
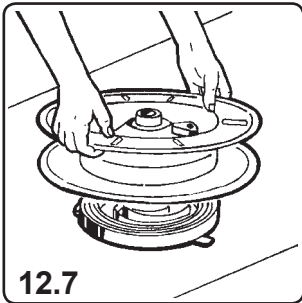

12.9) Put the drum straight and place the new spring housing centre with the utmost care. Block the tangs.

12.10) Assemble all the parts and go on as indicated at point 7.3 of the chapter "Mounting of the hose"



## 13 - DISPOSING OF CONTAMINATED MATERIALS

In case of maintenance or demolition by the machine, the parts that make it up must be sent to companies that specialize in the disposal and recycling of industrial refuse and, in particular:

### DISPOSAL OF PACKING MATERIAL

The packaging consists of biodegradable cardboard which can be delivered to companies for normal recycling of cellulose.

### DISPOSAL OF METAL COMPONENTS

Metal parts, whether paint-finished or in stainless steel, can be consigned to scrap metal collectors.

### DISPOSAL OF OTHER PARTS:

Other components, such as hoses, rubber gaskets and plastic parts, must be disposed of by companies specialising in the disposal of industrial waste.

EN

## 14 - EC DECLARATION OF CONFORMITY

The undersigned:

PIUSI S.p.A

Via Pacinotti c.m. z.i.Rangavino

46029 Suzzara - Mantova - Italy

**PIUSI**  
®

*Fluid Handling Innovation*

HEREBY STATES under its own responsibility, that the equipment described below:

Description: Automatic Reeling drum

Model: **HA20 ; HA/HN40 ; HA/HN60.**

Serial number: refer to Lot Number shown on CE plate affixed to product

Year of manufacture: refer to the year of production shown on the CE plate affixed to the product

is in conformity with the legal provisions indicated in the directives:

- Machine Directive 2006/42/EC

The documentation is at the disposal of the competent authority following motivated request at Piusi S.p.A. or following request sent to the email address: doc\_tec@piusi.com

The person authorised to compile the technical file and draw up the declaration is Otto Varini as legal representative.

Suzzara 09/12/2014

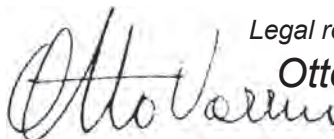

Legal representative

**Otto Varini**

## 1 - NORMES GÉNÉRALES APPLIQUÉES

Ce manuel a été conçu pour donner des renseignements pour un montage correct, pour l'utilisation et l'entretien des enrouleurs afin d'éviter de possibles accidents.

L'enrouleur a été projeté conformément aux actuelles normes de la Communauté Européenne.

Ce manuel a été rédigé conformément aux normes suivantes :

10653 : 2003 - Documentation technique - Qualité de la documentation technique de produit

10893 : 2000 - Documentation technique de produit - instructions pour l'utilisation - Articulation et ordre d'exposition du contenu.

## 2 - GARANTIE

Les enrouleurs sont garantis pour une période de 18 mois à compter de la date de fabrication et ils doivent être utilisés conformément aux instructions contenues dans ce manuel. La garantie ne couvre pas les pièces qui sont défectueuses à cause d'une utilisation non conforme aux instructions pour l'opération, d'une mauvaise installation ou maintenance, d'un entretien effectué par du personnel non autorisé, des dommages de transport ou provenant de circonstances qui résultent ne pas être des défauts de fabrication. Le fabricant décline toute responsabilité pour les dommages qui peuvent, directement ou indirectement, arriver à des personnes et/ou des biens à cause d'un défaut d'observance de toutes les prescriptions spécifiées dans le présent manuel et, en particulier, lesquelles concernant l'installation, l'utilisation et l'entretien de l'appareil.

## 3 - DESCRIPTION

Les enrouleurs modèles sont construits en acier galvanisé à chaude, moulé et laqué à poudre en polyester pour garantir une bonne durée dans le temps.

Les appareils enroulent automatiquement le tuyau par un ressort en acier de haute qualité incorporé dans le tambour et permettent de l'arrêter à la longueur souhaitée par un dispositif automatique.

**Les enrouleurs sans tuyau sont livrés avec le ressort déchargé. Suivre les instructions du chapitre "MONTAGE DU TUYAU".**

## 4 - FONCTIONNEMENT

Le cliquet d'arrêt fonctionne sur une zone correspondante à 1/3 de tour du tambour. Pour débloquer le tuyau, exercer une courte traction sur celui-ci.



**Il est important de toujours retenir le tuyau lors de l'enroulement pour éviter d'éventuels accidents corporels ou de dégâts à l'appareil ou aux objets environnants.**

## 5 - USAGE PREVU DE LA MACHINE

Les enrouleurs de la série vernie peuvent être utilisés pour la distribution d'air comprimé, huile, graisse, eau et antigel/essuie-glace.

**Tous les enrouleurs doivent être utilisés seulement pour la distribution de fluides aux pressions et températures indiquées sur les prospectus (voir les annexes à la fin du manuel).**

A chaque modèle correspond un tuyau spécifique. **Ne pas distribuer de fluides différents de ceux prévus.**



Le constructeur décline toute responsabilité pour les anomalies ou les dangers causés par un montage de tuyaux avec des caractéristiques et utilisations différentes de celles décrites.

- Éviter de monter sur l'appareil ou d'y appuyer n'importe quel type de matériel.
- Contrôler de temps en temps que l'enrouleur fonctionne correctement, qu'il n'y ait pas de pertes de fluide et que les raccords soient bien serrés.
- Fermer l'alimentation à la fin du service pour éviter des dégâts pendant les heures de repos.
- **L'enrouleur ne peut pas être utilisé en atmosphères potentiellement explosives (ATEX).**



**15 - DATI TECNICI  
TECHNICAL DATA  
FICHES TECHNIQUES**

**TECHNISCHE DATEN  
DATOS TÉCNICOS  
DADOS TÉCNICOS**

Modelli senza tubo / Models without hose  
Modèles sans tuyau / Modelle ohne Schlauch  
Modelos sin manguera / Modelos sem tubo

FLUIDO FLUID FLUIDE FLÜSSIGKEIT FLUIDO FLUIDO	MAX. 	CODICE CODE CODE ART. NR. CÓDIGO CÓDIGO	ENTRATA INLET ENTREE EINGANG ENTRADA ENTRADA	TUBO DIAM. HOSE DIAM. TUYAU SCHLAUCH MANGUERA TUBO DIAM.	LUNGH. TUBO HOSE LENGHT LUNGU. TUYAU SCHLAUCHLANGE LONG. MANGUERA COMP. TUBO		PRE LOAD 
ARIA - AIR AIR - LUFT AIRE - AR	60 Bar	HN60151200	G 1/2" M	-	15 m	14	4
OLIO - OIL HUILE - OEL ACEITE - ÓLEO		HN60153800	G 3/8" M	-	15 m	14	2
ACQUA - WATER EAU - WASSER AGUA - ÁGUA 40°C Max		HN60201200	G 1/2" M	-	20 m	18,5	1
		HN60153400	G 1" F	-	15 m	19	3
GRASSO - GREASE GRAISSE - FETT GRASA - GRAXA	400 Bar	HN60101000	G 1" F	-	10 m	19	3
		HN40151400	G 1/4" F	-	15 m	14	2
		HN40153800	G 3/8" F	-	15 m	14	2

Modelli completi di tubo / Models with hose  
Modèles avec le tuyau / Modelle mit Schlauch  
Modelos con manguera / Modelos com tubo

FLUIDO FLUID FLUIDE FLÜSSIGKEIT FLUIDO FLUIDO	MAX. 	CODICE CODE CODE ART. NR. CÓDIGO CÓDIGO	ENTRATA INLET ENTREE EINGANG ENTRADA ENTRADA	TUBO DIAM. HOSE DIAM. TUYAU SCHLAUCH MANGUERA TUBO DIAM.	LUNGH. TUBO HOSE LENGHT LUNGU. TUYAU SCHLAUCHLANGE LONG. MANGUERA COMP. TUBO		PRE LOAD 
ARIA - AIR AIR - LUFT AIRE - AR	18 Bar	HA20153800	G 3/8" F	10 x 17	15 m	16,5	4
ACQUA - WATER EAU - WASSER AGUA - ÁGUA 40°C Max		HA20151200	G 1/2" F	13 x 20	15 m	17	2
ANTIGELO/LAVAVETRI ANTIFREEZE/WINSHIELD ANTIGEL/ESSUI-GLACE FROSTSCHUTZMITTEL/ SCHEIBENWISCHERS ANTICONGELANTE/ LAVAPARABRISAS	18 Bar	HA201512AL	G 1/2" F	13 x 20	15 m	17	2
OLIO - OIL HUILE - OEL ACEITE - ÓLEO	60 Bar	HA60101200	G 1/2" M	1/2"	10 m	16,5	2
		HA60151200	G 1/2" M	1/2"	15 m	19	2
		HA60201200	G 1/2" M	1/2"	20 m	25	1
		HA60153400	G 1" F	3/4"	15 m	27	2
		HA60101000	G 1" F	1"	10 m	25	2
GRASSO - GREASE GRAISSE - FETT GRASA - GRAXA	400 Bar	HA40151400	G 1/4" F	1/4"	15 m	19	2
		HA40153800	G 3/8" F	3/8"	15 m	23	2

### Revolving Stand - Optional

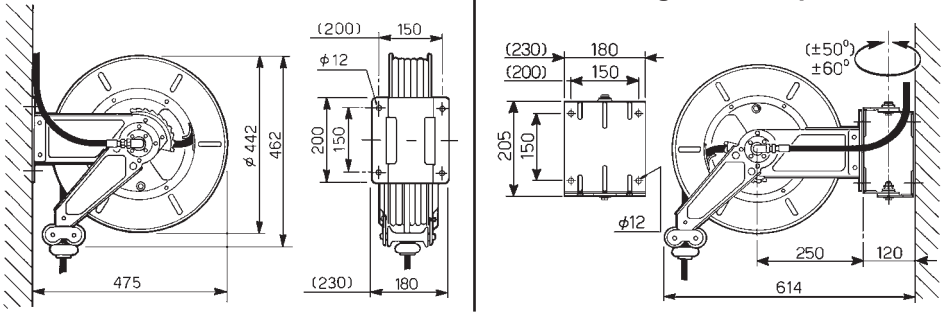

( ) HN/HA60201200

### Carter - Optional

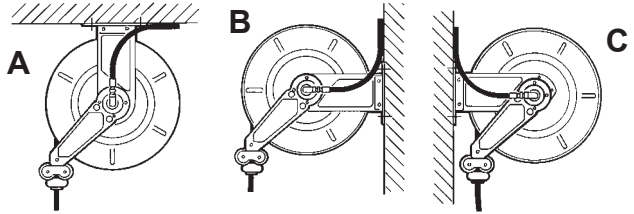
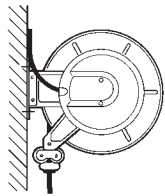

### HN/HA60153400 - HN/HA60101000

### Revolving Stand - Optional

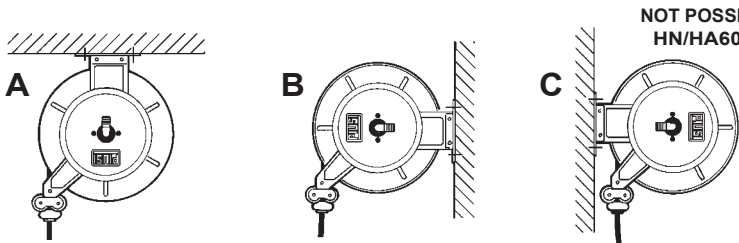
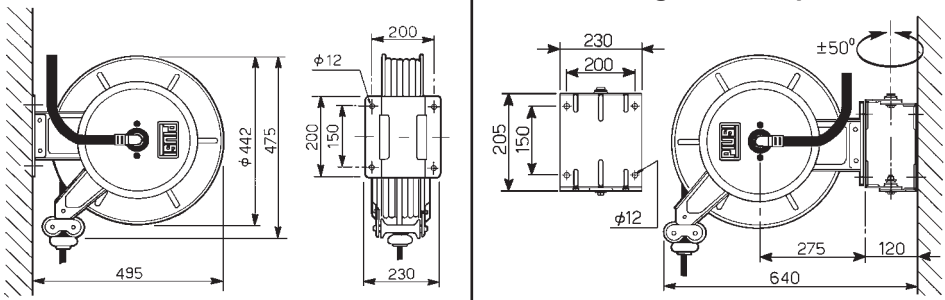

**NOT POSSIBLE FOR  
HN/HA60101000**



**Obbligo di conservazione del manuale**

E' fatto obbligo di conservare codesto manuale in un luogo facilmente accessibile, a disposizione di tutti gli operatori.

**Obligation to preserve the manual**

This manual must be kept in an easily accessible place, available to all operators.

**Obligation de conservation de la notice**

Il est obligatoire de conserver cette notice dans un endroit aisément accessible, à disposition de tous les opérateurs.

**Erhaltungspflicht des Handbuchs**

Man muss das Handbuch in einem leicht erreichbaren Ort erhalten, wo jede Arbeiter es verwenden kann.

**Obligación de conservar el manual**

Y 'obligados a mantener codesto Manual en un lugar fácilmente accesible y disponible para todos los operadores.

**Obrigaçã o de conservaçã o do manual**

É obrigado conservar este manual em um local facilmente acessível, à disposiçã o de todos os operadores.



[www.petroind.com](http://www.petroind.com)

# PETRO Contact Information

## AFRICA

### South Africa

Factory 1 - 16 Bentonite Street  
Alrode, Alberton, Johannesburg  
South Africa  
P: +27 (0)11 864 7758  
F: +27 (0) 11 864 1649  
E: sales@petroindustrial.co.za

## AUSTRALIA

### Eastern Australia

Factory 2, 106 Potassium Street  
PO Box 407  
Narangba QLD 4504  
P: 07 3204 9558  
F: 07 3293 4852  
E: sales@petroindustrial.com.au

## UAE

### Dubai

Office LB17330, Lobby Building 17  
Jebel Ali Free Zone  
PO Box 18602  
Dubai, United Arab Emirates  
P: +971 488 76688  
F: +971 488 76932  
E: salesuae@petroind.com

### Western Australia

2 Competition Way  
Wangara WA 6065  
P: 08 6305 0855  
F: 08 6305 0319  
E: sales@petroindustrial.com.au

# PETRO INDUSTRIAL



[petroind.com](http://petroind.com)