

DO NOT SCALE FROM DRAWING. IF IN DOUBT: ASK

UNLESS OTHERWISE SPECIFIED, ALL DIMENSIONS ARE IN MILLIMETRES

BEWARE OF 100mm MEASURING ERROR

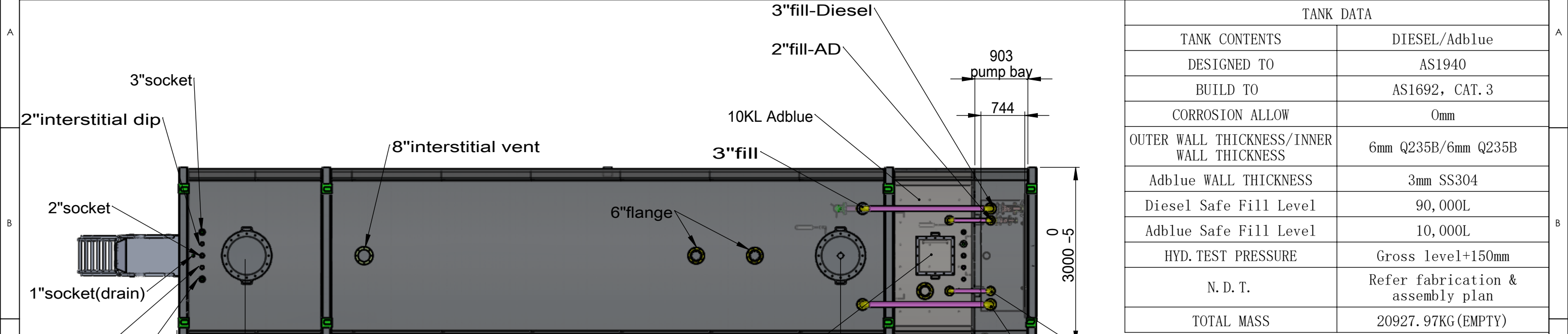

TANK DATA	
TANK CONTENTS	DIESEL/Adblue
DESIGNED TO	AS1940
BUILD TO	AS1692, CAT. 3
CORROSION ALLOW	0mm
OUTER WALL THICKNESS/INNER WALL THICKNESS	6mm Q235B/6mm Q235B
Adblue WALL THICKNESS	3mm SS304
Diesel Safe Fill Level	90,000L
Adblue Safe Fill Level	10,000L
HYD. TEST PRESSURE	Gross level+150mm
N. D. T.	Refer fabrication & assembly plan
TOTAL MASS	20927.97KG (EMPTY)

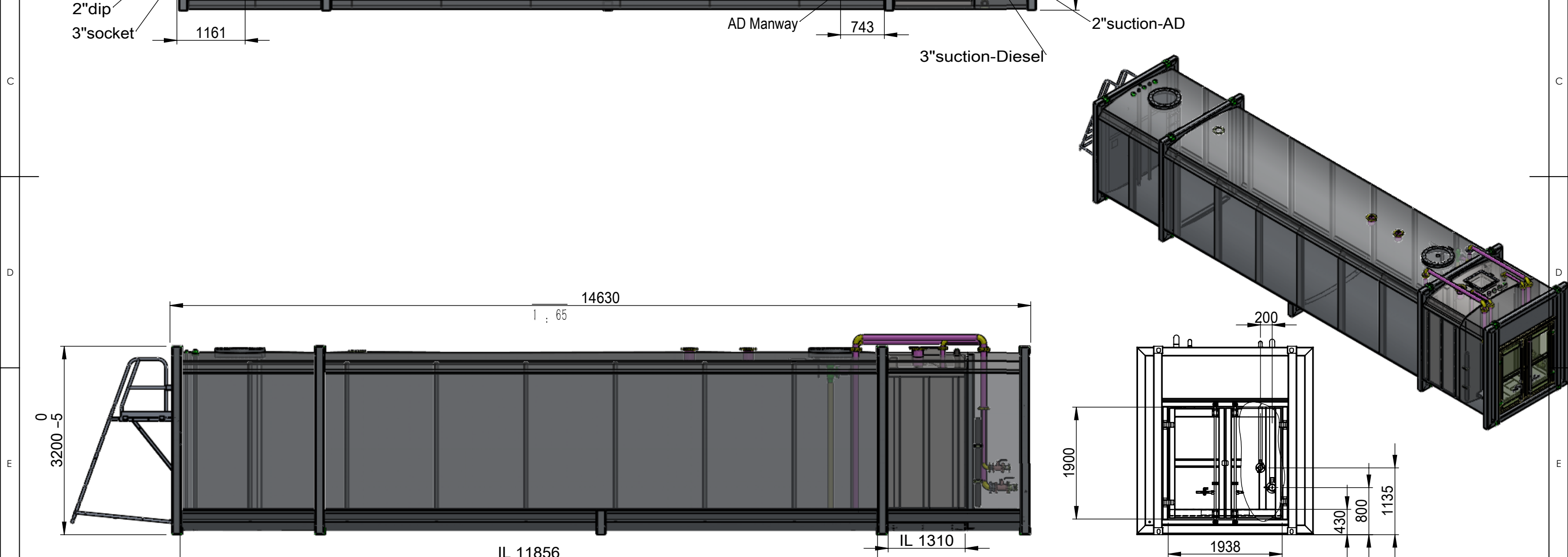

THIRD ANGLE PROJECTION		DWG NO. / PART NO. PT110 AD10KL	JOB NO.									
COPYRIGHT © 2022 THE CONTENTS OF THIS DRAWING REMAINS THE PROPERTY OF PETRO Industrial. CONTENTS MAY NOT BE COPIED OR REPRODUCED UNLESS PREVIOUSLY AUTHORIZED		CLIENT:										
<table border="1"> <thead> <tr> <th>NAME</th> <th>DATE</th> </tr> </thead> <tbody> <tr> <td>DRAWN</td> <td>2022/1/20</td> </tr> <tr> <td>CHK'D</td> <td></td> </tr> <tr> <td>APPV'D</td> <td></td> </tr> </tbody> </table>	NAME	DATE	DRAWN	2022/1/20	CHK'D		APPV'D		TOLERANCE U.N.O. 0 = -1.0 0.0 = -0.4 0.00 = -0.1	MATERIAL: WEIGHT: 20927.97 Kg	TITLE: SCALE: N.T.S.	SHEET SIZE A3 REVISION 01
NAME	DATE											
DRAWN	2022/1/20											
CHK'D												
APPV'D												
		SHEET 1 OF 2										

DO NOT SCALE FROM DRAWING. IF IN DOUBT: ASK

UNLESS OTHERWISE SPECIFIED, ALL DIMENSIONS ARE IN MILLIMETRES

BEWARE OF 100mm MEASURING ERROR

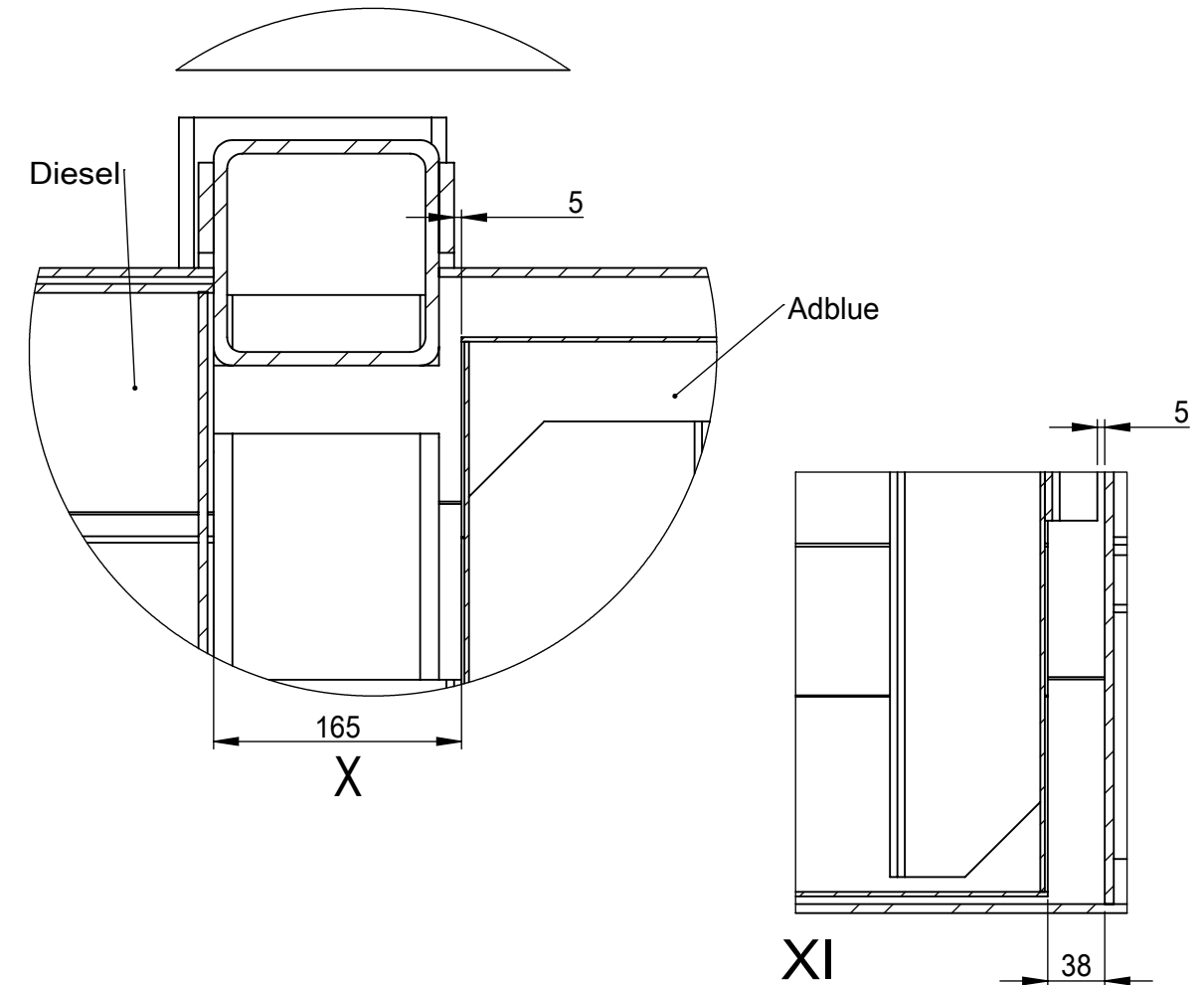
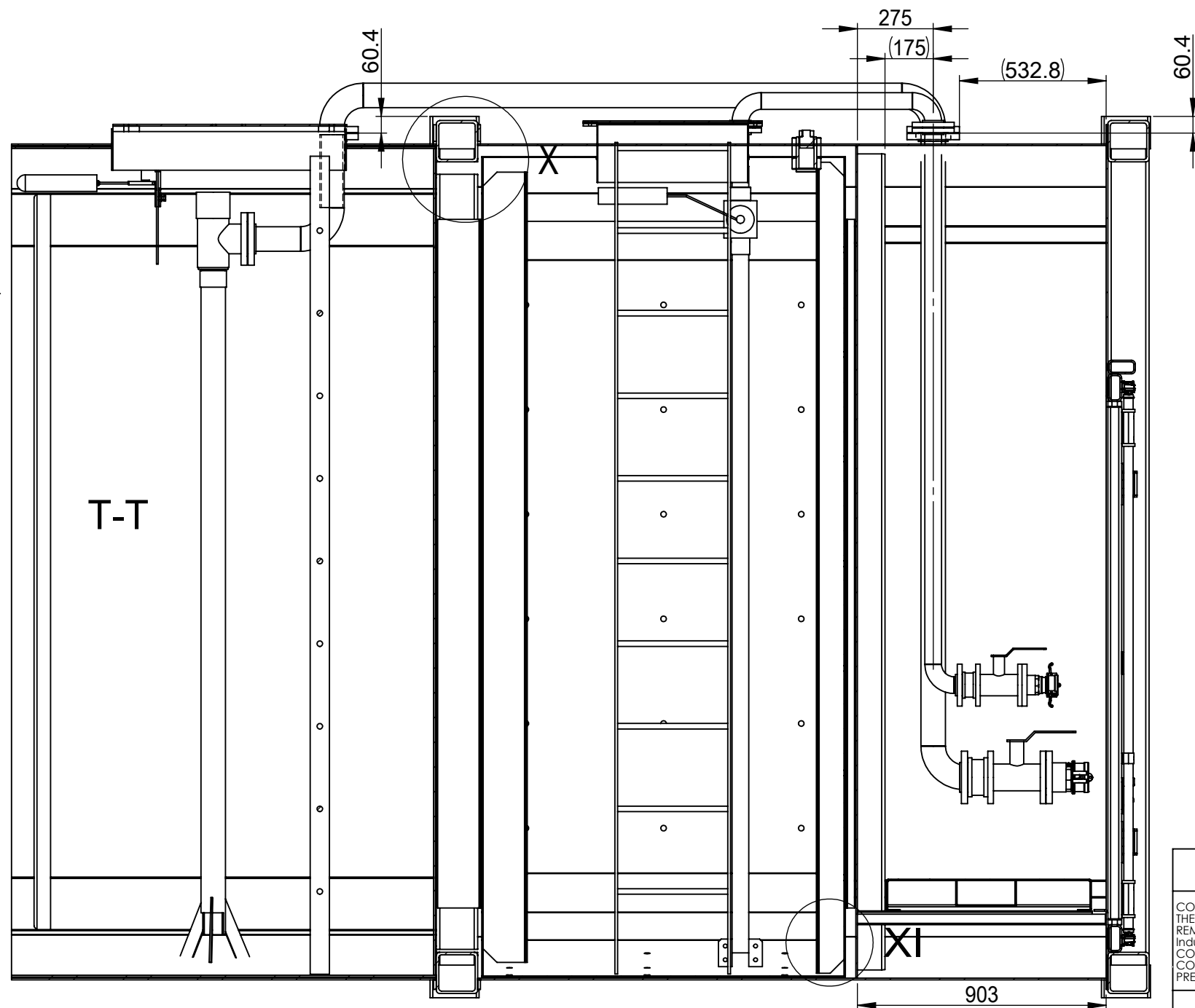
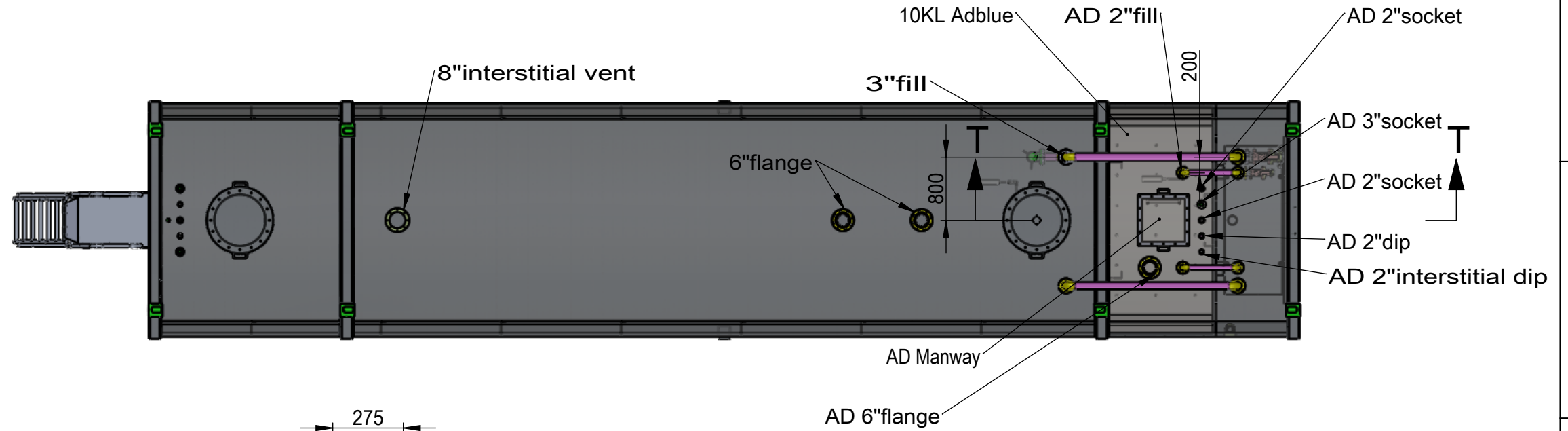

THIRD ANGLE PROJECTION

COPYRIGHT © 2022 THE CONTENTS OF THIS DRAWING REMAINS THE PROPERTY OF PETRO Industrial. CONTENTS MAY NOT BE COPIED OR REPRODUCED UNLESS PREVIOUSLY AUTHORISED

	NAME	DATE
DRAWN		2022/1/20
CHK'D		
APP'V'D		

PETRO INDUSTRIAL

000L 0000000

TOLERANCE U.N.O.
 0 = -1.0
 0.0 = -0.4
 0.00 = -0.1

MATERIAL:
 WEIGHT: 20927.97 Kg

DWG NO. / PART NO. PT110 AD10KL		JOB NO.
CLIENT:		
TITLE:		SHEET SIZE A3
SCALE: N.T.S.	SHEET 2 OF 2	REVISION 01