



Diesel Dispensing

## ST BOX 12V DC STEEL CABINET PUMP KIT

The PIUSI ST BOX is a diesel refueling station complete with pump, flow meter and filter, with lockable metal protection box. The unit is complete with antistatic hose for diesel fuel and automatic dispensing nozzle. The PRO version features the electronic access control box ACCESS 85.

### FEATURES:

- Lockable Steel Cabinet.
- Piusi 12V DC Bi-Pump.
- ON/OFF switch.
- K33 Meter.
- 4m Delivery hose.
- A120 Automatic shut off nozzle.
- Nozzle Contact (Pro version only).

### PERFORMANCE:

- Flow rate: up to 90lpm.
- Accuracy: +/- 1%.
- Operation: AC Continuous.
- Noise level: below 75 dB.



### Fittings:

1. K33 flow meter
2. Bi-Pump
3. Automatic nozzle
4. Swivel connection (\*)
5. Nozzle holder with switch(\*)
6. Access 85 (\*)
7. 10 user keys (\*)
8. 1 manager key (\*)

(\*) PRO version only

Dimensions: 582mm H x 564mm W

# PETRO INDUSTRIAL



petroind.com



## PRODUCT RANGE:

Code	Description	Flow Rate		Pump mod.	Voltage			Meter mod.	Nozzle type	Filter HzO	Inlet BSP	Hose
		lpm	gpm		ACV./Hz DC Volt	Power Watt	Amp. max.					
F0039900A	ST BOX Bi-Pump 12V	80	21	Bi-Pump	12	530	44	K33	A120	No	1"	4m x 1"
-	ST BOX Bi-Pump Pro 12V	80	21	Bi-Pump	12	530	44	K33	A120	No	1"	4m x 1"

## SHIPPING:

Weight		Packaging		
kg	lbs	mm	inch	pcs/box
50	110	590 x 340 x 720	23,2 x 13,4 x 28,3	1

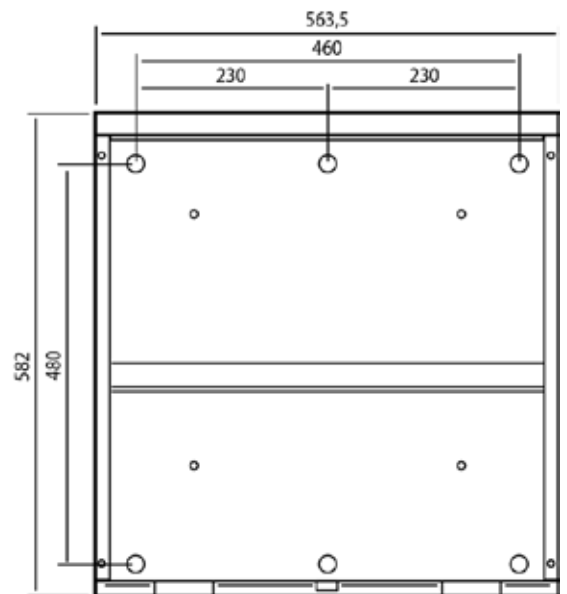

## OPTIONAL:

