



ADBLUE®

SQUAL035 SUBMERSIBLE PUMP

SQUAL035 is the first submersible pump for AdBlue® to have been especially developed and tested for distribution systems.

A centrifugal pump fitted with a turbine regenerator with non-return valve and a built-in innovative pressure regulation system that optimises flow rate performance levels.

Consistent flow rate and accuracy during delivery dramatically reduce energy consumption levels.

The compact size and special pump design make for easy installation and near-complete emptying of the intended installation tank.

FEATURES:

- Heavy Duty
- Regenerative Turbine
- Integrated Pressure Regulator
- Built-In Non Return Valve

PERFORMANCE:

- Up to 35 lpm Flow Rate
- AC Voltage
- 30mm Dead Level



Mesh Strainer

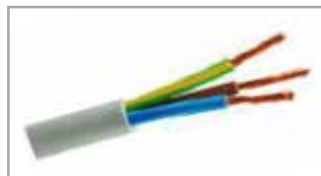

5 Meter Power Cord



Built-In Non Return Valve



Pressure Equalizer

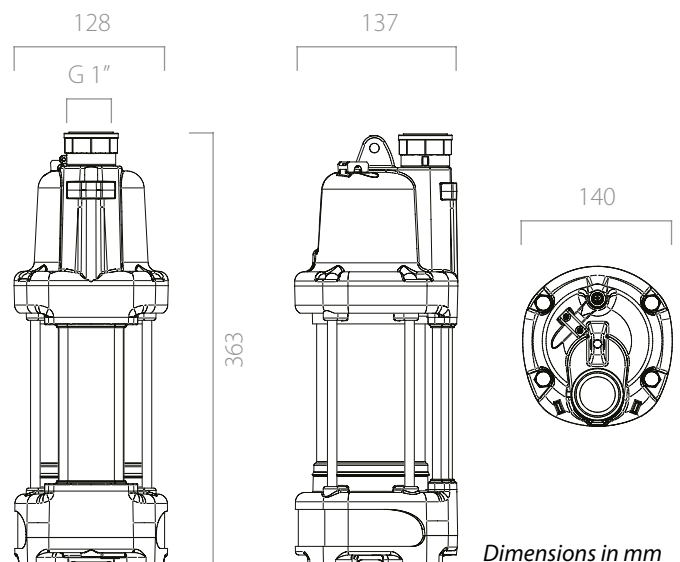

PETRO INDUSTRIAL



petroind.com



MATERIALS:

- **Body:** Stainless Steel/Technopolymer
- **Turbine:** Technopolymer

PRODUCT RANGE:

Code	Description	Flow Rate		Working Pressure	Dead Level	Voltage		Power Cord
		LPM	GPM			CA V/HZ	CC V WATT	
F00206020	SQUAL035 230/50 TIMER	35	7,7	1,8 BAR 27 PSI	2" BSP	230/50	560	5m

PACKAGING:

Weight		Packaging		
KG	LBS	mm	inch	PCS/BOX
7	15,4	510 x 240 x 150	20 x 9,4 x 5,6	1

