

PETRO INDUSTRIAL



petroind.com



EX100 / EX140

HIGH FLOW TRANSFER PUMP

EX100 Item code: F00390010

EX140 Item code: F00395010



The entirely **NEW EX line** is characterized by a high flow rate that works with a continuous duty cycle, and has been designed to be particularly suitable for Heavy Duty, i.e. for those demanding fleets that need to dispense fuels such as Gasoline, diesel or kerosene quickly.

FEATURES:

- High Flow Rate
- Heavy Duty
- Continuous Duty
- Thermal Protection
- UI Version Available
- Removable Pump Feet

Body: Cast Iron
Rotor: Sintered Steel
Vanes: Technopolymer
Seal: Viton
Shaft: Steel

PERFORMANCE:

- Up to 140 L/min Flow Rate
- Power: AC Voltage

TECHNICAL DATA:

Code	Description	Flow Rate		Voltage			RPM	Inlet	Outlet
		Lpm	Gpm	AC Volt/Hz	Power Watt	Amp max.		BSP	BSP
F00390010	EX 100 230/50	100	25	230/50	1035	4,5	1450	1" 1/4	1"
F00390020	EX 100 230/60	100	25	230/60	874	3,8	1750	1" 1/4	1"
F00395010	EX 140 230/50	140	37	230/50	1150	5	1450	1" 1/4	1"
F00395020	EX 140 250/50	140	37	250/50	1125	4,5	1450	1" 1/4	1"
F00395030	EX 140 230/60	140	37	230/60	920	4	1750	1" 1/4	1"

(*) Upon Request it is available with different voltages and 60 HZ frequency.

Compatible Fluids: Diesel, Kerosene, Petrol, Petrol Alcohol mixed max 15%, Avgas 100/100LI, Jet A/A1 - Aspen 2/4

PETRO INDUSTRIAL



petroind.com



OUR PUMPS COMPLIES WITH THE FOLLOWING MARKING ATEX/IECE_x

II	2	G	Ex	d	IIA	T4	Gb
Group	Category	Type Of Explosive Atmosphere	Permanent Prefix	Protection Method	Gas Glass	Temperature Class	Equipment Protection Level

DIMENSIONS (mm):

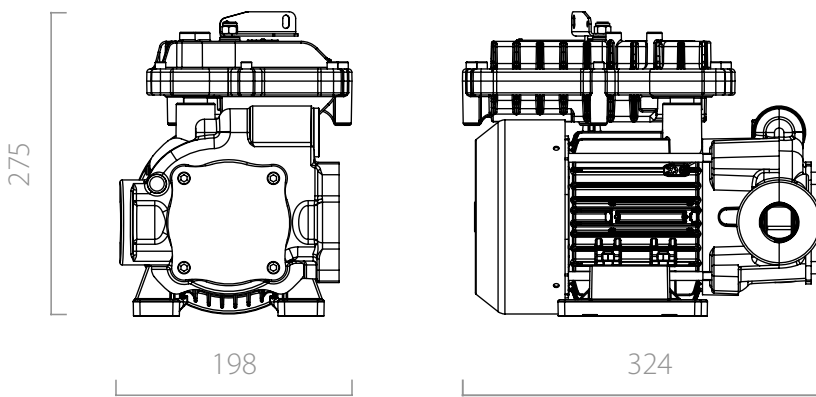
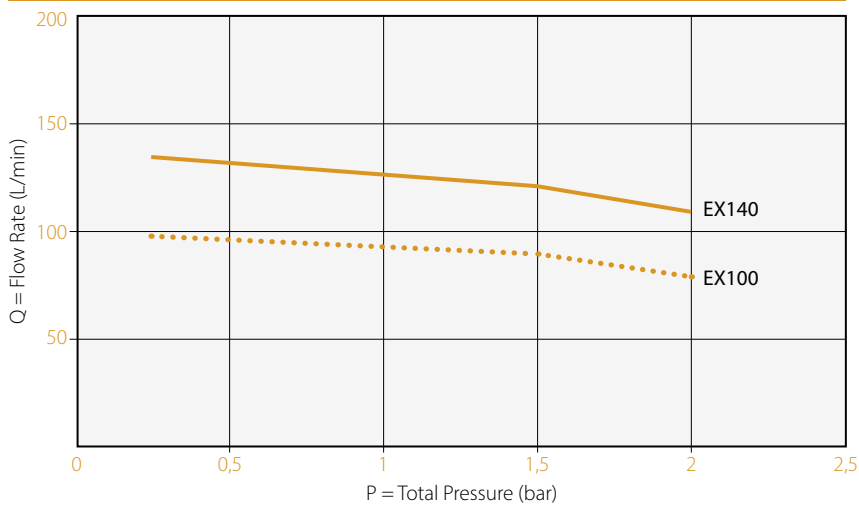

CHART:



SHIPPING:

Weight		Packaging	
Kg	Lbs	mm	Inch
25	55	240 x 400 x 350	9,4 x 15,7 x 13,8