



E140

## DIESEL TRANSFER VANE PUMP

Item code: F00395060

The E140 diesel transfer pump is versatile and suitable for different industries including automotive, agriculture, transportation, garages and construction.

The E140 volumetric, self-priming vane pump for diesel transfer has a high seal and is reliable in conditions of use at low temperatures.

With its solid and resistant body, the E140 is an easy to install diesel transfer pump, suitable for use in diesel dispensers and fixed fuel transfer systems, as well as other industrial applications.

The compact cast iron structure makes the E140 electric pump the perfect system for performance and reliability.

### FEATURES:

- Continuous Duty
- High Flow-Rate
- Heavy Duty Pump
- Sturdy Design

**Body:** Cast Iron  
**Rotor:** Sintered Steel  
**Vanes:** Technopolymer  
**Seal:** Viton  
**Shaft:** Steel

### PERFORMANCE:

- Up to 140 L/min Flow Rate
- Power: AC Voltage

### TECHNICAL DATA:

Code	Description	Flow Rate		Voltage			Continuous Duty	Inlet BSP
		Lpm	Gpm	AC Volt/HZ	Power Watt	Amp max.		
F00395060	E 140	140	37	250	1150	5	S1	1" 1/4

### SHIPPING:

Weight		Packaging	
Kg	Lbs	mm	Inch
18	40	350 x 250 x 300	14 x 10 x 12

# PETRO INDUSTRIAL



petroind.com



## DIMENSIONS (mm):

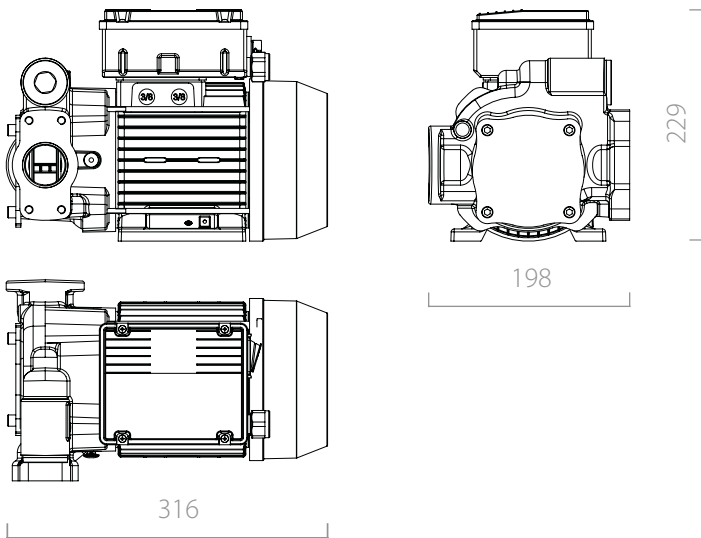

## CHART:

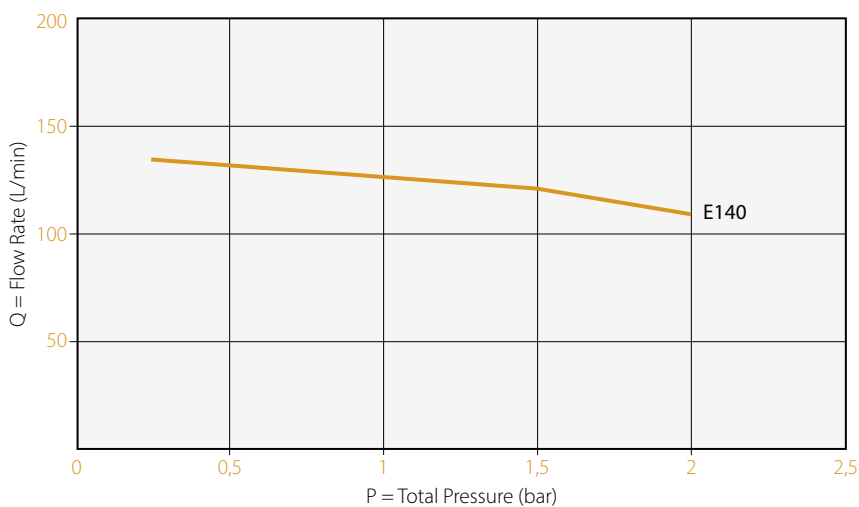

Type of Fluid: Diesel  
Temperature: 20 °C

