



OIL SAMPLING SOLUTIONS FOR THE MINING INDUSTRY

STATIONARY
SAMPLING
SOLUTIONS

MOBILE
SAMPLING
SOLUTIONS



WHY USE OIL SAMPLING VALVES?

For years companies have used oil analysis to determine the health and condition of their equipment. Most recognize the value of using oil analysis to avoid unplanned equipment downtime and for planning oil changes. However, most companies are not getting the most out of their oil analysis program because they do not understand the importance of proper oil sampling.

Oil samples are the important first step in any oil analysis program. Without one, the lab would have nothing to analyze. The aim of any predictive oil analysis program is to trend any gradual changes in fluid properties, contaminants and wear debris so that corrective action can be started in a controlled, planned manner. The results from your sample will determine if corrective actions need to be taken. An improper sample can skew these results, producing either costly false negatives or false positives. Ultimately those improper samples can cause an oil analysis program to be abandoned.

A proper sample represents the true condition of the equipment. It's taken while the equipment is running and it is taken from the same spot every time.

Sampling valves are the best method for obtaining proper, reliable oil samples. They make it possible to take oil samples safely, while the equipment is running, from the same spot, every time. This means that oil samples can be taken at any time since shutdowns are no longer necessary. Sampling, while the equipment is running, ensures that the sample is a direct representation of the equipment's condition. Additionally, the oil sample is coming from the same spot in the active zone every time, away from the sediment and filters. Meaning that the sample pulled will contain hot, information-rich oil that can be trended against previous samples to show the condition of your equipment.



Different types of equipment require different types of sampling valves.

We've developed our range of sampling valves and tubes to cover the needs of both stationary and mobile equipment.



FOR STATIONARY EQUIPMENT:

- LTJ Sampling Tube



FOR MOBILE EQUIPMENT:

- KP Pushbutton
- Sampling Centre
- LE Series
- Drive Position Indicator

THE LTJ SAMPLING VALVE

The same great L valve with a universal port. The LTJ Sampling Tube makes gearbox sampling simple. Install into a readily available port using a standard -8 JIC Flare fitting.

The standard swivel helps easily position the tube to draw oil directly from the active zone while the equipment is running, leading to more reliable, trendable, and repeatable samples.

BENEFITS:

- Sampling tube draws only oil from the active zone.
- Sample high viscosity gear oils without shutting down.
- Samples 7x faster than the B16x2 series.
- Zinc-nickel based corrosion protection offers 5 - 7x more life than industry standard.
- Installs compactly into almost any port without special tools or multiple adapters.
- Detect oil levels and discoloration more accurately and from any angle with the 3D Sight Glass.
- Sampling range 0 - 125 psi.



FEATURES:

- High flow flushface valve is designed to be able to sample high viscosity gear oils up to VG 1500
- JIC style offers one less connection point- use -8 JIC Flare standard fitting for port installation
- Swivel feature allows for easy bending and positioning of the tube to draw from the active zone

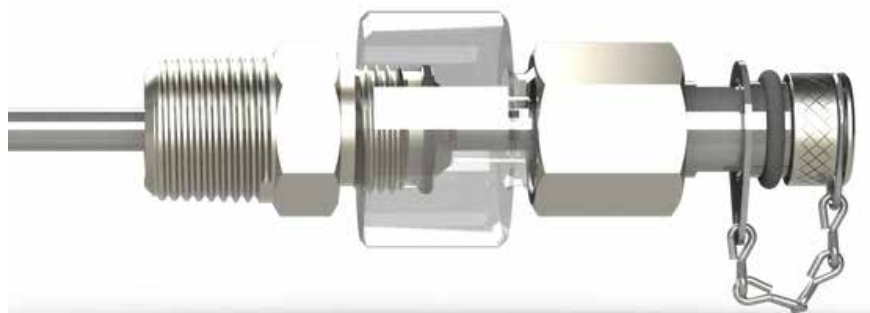

Gearboxes | Reservoirs

THE KP PUSHBUTTON

The KP Pushbutton allows for easy sampling of pressurized systems by pushing a button. The push button style eliminates the need for probes and cross-contamination risks.

To sample, hold the bottle under the spout of the button and then push.

BENEFITS:

- No probes needed.
- Low purge volume.
- Patented elastomeric vacuum tight seals.
- Automatic valve shutoff.
- Remote access available.
- Sampling range of 5 - 750 psi.



FEATURES:

- Unique 360° rotating spout offers convenient sampling and installation without swivel fittings.
- Push button style valve: push to open valve, release to automatically close valve.
- Weather sleeve.
- Rugged spout design with easy to grip knurled cap.
- Variety of thread options for direct installation.
- Corrosion resistant stainless steel chain and clip with no exposed springs.

Hydraulics | Engines | Compressors | Engines | Coolant | Turbines

THE SAMPLE CENTER (SC)

The SC relocates all of your system's sampling valves into one easy to access location. The SC allows you to draw a highly representative sample through the use of a bypass loop.

This loop stays active even when no sample is being taken, allowing technicians to avoid the guess work of purge volumes.

BENEFITS:

- Low purge volumes.
- Sample up to 5 different ports from one safe ground location.
- Each port of the manifold block is customized for the circuit - restricting pressure for high-pressure circuits and increases flow for lowpressure circuits.
- Pushbutton style valves and case help remove environmental challenges.



Engine | Hydraulics | Transmission | Coolant | Steering
Compressor | PTO | Crusher Lube | Pump Drive | Brakes
Gearbox | Wheel Motor

THE LE SERIES

The LE Valve is a low-profile sampling valve recessed in a drain plug. The LE replaces existing plugs to allow for oil sampling without removing the drain plug and opening the system up to moisture and contamination.



BENEFITS:

- High flow flush faced valve samples high viscosity gear oils up to VG 1500.
- Get a clean, representative sample without removing the drain plug.
- Compact - only 0.64" (16mm) clearance required.
- Use with the Drive Position Indicator (DPI) to position the drive for faster, more accurate servicing (pg. 8).
- Sampling range of 0 - 125 psi.



FEATURES:

- Either a hexed or slotted cap style (hex style displayed).
- Dual weather sealed cap.
- Zinc-nickel based corrosion plating offers 7 x more life protection than the industry standard.

Final Drives

THE DRIVE POSITION INDICATOR (DPI)

The DPI lets the operator see exactly when the planetary drive wheel is properly positioned to check the fluid level and change the oil, even on uneven surfaces.

Just attach the DPI sensor to the wheel magnetically and move your equipment forward and back until the DPI indicator unit signals that the track drive or wheels have rotated into the required position.

BENEFITS:

- No complicated setups - the DPI travels in a compact package and set up takes seconds
- The sensor can be set to indicate when the drive is in position for draining, filling, level check or sampling
- Any technician can position the drive accurately the first time
- Reduce the chance of slips and falls from climbing up and down the equipment
- Multiple factory programmed frequencies allow for multiple DPI kits to function in close proximity without interference



Final Drives

SAMPLING PROBES FOR:

LTJ/LE Series

L sampling probe, thread on (vacuum - 125 psi / 0.86 MPa) use 1/4" poly tubing.

LF-4NF Reusable

L sampling probe, thread-on, with 1/4" OD quick attach/detach (vacuum - 125 psi / 0.86 MPa) use 1/4" poly tubing.



LT Sampling Tube with SLF4 probe, SER4 tubing, and Vacuum Pump

ACCESSORIES FOR:

LTJ/LE Series

Vacuum Pump (VAC)

Required for retrieving samples from the LT/LTJ Valve

Plastic Tubing (SER4-100)

Required for retrieving samples from the LT/LTJ Valve

All Valves

Sampling Bottle (LC)

Sample bottle, clear PET, ribbed (125 ml, 4 oz)

PETRO Contact Information

AFRICA

South Africa

Factory 14 Bentonite Street
Alrode, Alberton, Johannesburg
South Africa
P: +27 (0)11 864 7758
F: +27 (0) 11 864 1649
E: sales@petroindustrial.co.za

AUSTRALIA

Eastern Australia

Factory 2, 106 Potassium Street
PO Box 407
Narangba QLD 4504
P: +61 (0) 7 3204 9558
F: +61 (0) 7 3293 4852
E: sales@petroindustrial.com.au

MIDDLE EAST

Dubai

Office LB17233, Lobby Building 17
Jebel Ali Free Zone
PO Box 18602
Dubai, United Arab Emirates
P: +971 488 76688
F: +971 488 76932
E: salesuae@petroind.com

Western Australia

173 Mulgool Road
Malaga WA 6090
P: +61 (0) 8 6305 0855
F: +61 (0) 8 6305 0319
E: info@petroperth.com.au

PETRO INDUSTRIAL



petroind.com