

SPECIFICATIONS

700-15 Flow Meter

TOTAL CONTROL SYSTEMS



Total Control Systems rotary positive displacement flow meters offer reliable and precise measurement solutions for preset delivery, flow rate control, blending and custody transfer of vehicle or wholesale measurement applications.

INDUSTRIES SERVED

- Petroleum Products
- Alternative Fuels
- Aviation Fuels
- Agricultural Chemicals
- Petrochemicals
- Textiles
- Foods and Beverages
- Paints and Coatings
- Pharmaceuticals
- Printing Inks

DESIGN

The 700-15 flow meter has a simple and efficient meter design consisting of a housing and three rotors that rotate in unison within the measuring chamber. The absence of wear, from no metal-to-metal contact inside the chamber, eliminates any deterioration in accuracy and provides a long service life. The rotors are supported by bearings inserted into two bearing plates, where at the end of each rotor shaft is a timing gear. The timed rotation between each rotor is then transferred through the calibration adjuster to the register, which will then give a consistent and superior measurement of accuracy.



FLOW ILLUSTRATION

PERFORMANCE FEATURES

LOW PRESSURE DROP: will operate on gravity flow or pump pressure

SUSTAINED ACCURACY: no metal-to-metal contact inside the measuring chamber means minimal wear and deterioration in accuracy over time, fewer recalibrations and longer service life.

VISCOSITY RANGE: will accurately measure liquids up to 1,500,000 SSU (325,000 CPS)

LINEARITY:
6:1 Turndown - capable of $\pm 0.10\%$ of maximum nominal flow rate
12:1 Turndown - capable of $\pm 0.15\%$ of maximum nominal flow rate

REPEATABILITY: capable of 0.02% over the entire range of flow

Data provided from test conditions where all system variables were constant. The results are based on the 700 series flow meter and Veeder Root mechanical registration, using 32 SSU testing fluid.

REGULATORY: Meets NIST, USA military and other international weights and measures accuracy requirements.

OPERATING SPECIFICATIONS

DESIGN TYPE: Positive Displacement Rotary Abutment

FLOW CAPACITY: 5 GPM to 60 GPM
19 LPM to 227 LPM

VISCOSITY: Up to 1,500,000 SSU (325,000 CPS)

PRESSURE RATING: 150 PSI
10.5 BAR

TEMPERATURE RATING: -40°F to 160°F
-40°C to 71°C

CONNECTIONS: 1-1/2" NPT Standard, 2" Optional. BSPT, Slip Weld, ANSI and DIN flanges are available upon request.

METER TYPES

SP Standard Petroleum

For metering refined petroleum products such as Leaded and Unleaded Gasoline, Fuel Oils, Diesel, Bio-Diesel, Kerosene, Jet Fuels, Vegetable Oils, Motor Oils, Ethylene Glycol (Anti-Freeze), etc.

SPA Standard Petroleum (Aviation)

For metering refined petroleum products; such as Regular and Unleaded Gasoline, Diesel, Bio-Diesel, Aviation Gasoline, Jet Fuel, Naptha, Kerosene, etc.

IP Industrial Products

For metering Food Processing Liquids, Industrial Chemicals, General Solvents and many other liquids; such as Liquid Sugars, Corn Syrup, Soy Bean Oil, Shortenings, Latex Products, Adhesives, etc.

IC Industrial Products (Carbon Graphite)

For metering Industrial Chemicals, General Solvents, Water and other Non-Lubricating Liquids, such as Alcohol, Acetones, Ethanol, Naphtha, Xylene, MEK, Toluene, Deionized Water, Demineralized Water, Potable Water, etc.

MATERIALS OF CONSTRUCTION

Meter Type	Housing	Rotors	Bearing Plates	Bearing Sleeves	Journals	Timing Gears	Internal Hardware	Seals
SP	Anodized Aluminum	Anodized Aluminum	Ni-Resist	Ni-Resist	Hardchrome Stainless Steel	Stainless Steel	Stainless Steel	Viton ®
SPA	Anodized Aluminum	Anodized Aluminum	Ni-Resist	Carbon Graphite	Hardchrome Stainless Steel	Stainless Steel	Stainless Steel	Viton ®
IP	Anodized Aluminum	Anodized Aluminum	Stainless Steel	Non-galling Illium 88 SS	Hardchrome Stainless Steel	Stainless Steel	Stainless Steel	Teflon ® & Simriz ®
IC	Anodized Aluminum	Anodized Aluminum	Ni-Resist	Carbon Graphite	Hardchrome Stainless Steel	Stainless Steel	Stainless Steel	Teflon ® & Simriz ®

Viton is a registered trademark of E.I. Dupont de Nemours & Co.
Teflon is a registered trademark of Dupont Dow Elastomers
Simriz is a registered trademark of Freudenberg-NOK

REGISTRATION OPTIONS

COUNTER REGISTER

Liquid measurement volume indication, using a 5 digit large numeral reset display and an 8 digit non-reset totalizer. Electronic or mechanical meter counter register is available. U.S. or Imperial Gallons, Liters, Dekaliter, Barrels, pounds, etc.

COUNTER PRESET

Select predetermined volume for precise batch control, utilizing preset control valve. Mechanical or electronic preset counters or batch controllers are available.

TICKET PRINTER

Provides an imprinted ticket record of each delivery transaction. Accumulative or Zero-Start, Face down or Face Up mechanical ticket printers available. Electronic slip or roll printers available for use with various electronic registration.

ELECTRONIC METER REGISTER

Digital liquid measurement volume indication that offers multiple functions to enhance the flow meter's accuracy and accountability. Most electronic registration are available with rate of flow indication, pulse output, valve control, RS232 and RS485 communication, currency and temperature compensation.

PULSE TRANSMITTER

The electronic pulse signal output converts the register counter volume per unit value into a electrical pulse stream. The electronic pulse stream can be transmitted to other electronic controllers for rate of flow, volume indication, additive injection or data acquisition.

TEMPERATURE COMPENSATION

Automatically corrects changes in volume caused by liquid temperature variations, during metered delivery. Normally corrects net volume or mass to 60°F (15°C) based on the product's coefficient of expansion, API or specific gravity.

MICROSWITCH

Mechanical signal from the Veeder Root preset counter converted into an electrical or pneumatic signal to provide control of remotely located valve, pump, and other system related equipment.

COUNTER EXTENSION

Raises the elevation of the counter registration for easy visibility or to protect from high temperatures. Counter Extension is required for temperatures more than 180°C (82°C).

RATE OF FLOW INDICATOR

Mechanical or digital indicator displays the volume at which the liquid is flowing through the flow meter.

SWIVEL

Allows mechanical registration to be rotated 360°. Designed for the Veeder Root counter register and ticket printer only.

METER ACCESSORIES

AIR ELIMINATOR

A float and reed valve operated design senses and removes free air or vapor before it can enter the flow meter. Required for custody transfer applications to ensure the most precise measurement.



ELECTRONIC PRESET VALVE

A normally closed two-stage piston preset valve for use with electronic relay control. The solenoid valves are available in 12 or 24 VDC, or 110 VAC coils. Stainless steel or brass pilot valves are also available. Dimensionally interchangeable with the mechanical valve.



STRAINER

A 90° strainer provides protection from debris entering into the flow meter. Must be mounted in vertical position when assembled with air eliminator. Stainless steel screens are available in 40, 80, 100 & 200 mesh, and 0.050 perforation.



PNEUMATIC PRESET VALVE

Air actuated, normally closed two-stage piston preset valve for use in systems with air supply. Dimensionally interchangeable with the mechanical valve.



MECHANICAL PRESET VALVE

A normally closed, hydraulically balanced piston control valve allows for auto-batch preset deliveries. The right angle, two-stage control valve is mechanically linked to Veeder Root Preset Counter.



WAFER CHECK VALVE

In-line check valve is mounted between the strainer and meter assembly to help increase air eliminator efficiency by creating additional back pressure. Available in plated steel or stainless steel.



ASSEMBLY COMBINATIONS

GROUP COMBINATIONS

- 2 **Meter & Register**
- 3 Meter, Register & Ticket Printer
- 4 **Meter, Register, Air Eliminator & Strainer**
- 4R **Meter, Register, Air Eliminator & High Volume Strainer**
- 5 Meter, Register & Strainer
- 6 Meter, Register, Ticket Printer, Air Eliminator & Strainer
- 6R Meter, Register, Ticket Printer, Air Eliminator & High Volume Strainer
- 7 Meter, Register, Printer, & Strainer
- 8 **Meter, Register, Preset & Valve**
- 9 Meter, Register, Ticket Printer, Preset & Valve
- 10 **Meter, Register, Preset, Valve, Air Eliminator & Strainer**
- 10R **Meter, Register, Preset, Valve, Air Eliminator & High Volume Strainer**
- 11 Meter, Register, Ticket Printer, Preset, Valve, Air Eliminator & Strainer
- 11R Meter, Register, Ticket Printer, Preset, Valve, Air Eliminator & High Volume Strainer
- 12 Meter, Register, Preset, Valve & Strainer
- 13 Meter, Register, Ticket Printer, Preset, Valve & Strainer

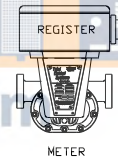

GROUP 2

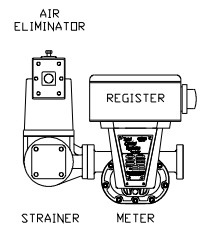

GROUP 4

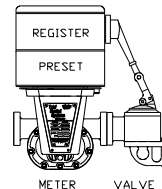

GROUP 8

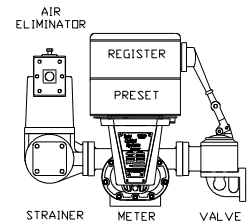

GROUP 10

METER ORIENTATION

- A Meter Assembly with Veeder Root Registration
- B Meter assembly less Veeder Root Registration
- C Meter Assembly for use with Electronic Registration (less calibration adjuster)
- D Meter Assembly with direct drive pulse transmitter



Meter A
(700-20SP10AT)



Meter B
(700-20SP10RBX)



Meter C
(700-20SP10CXA)



Meter D
(700-30SP2DX)

700-15 DIMENSIONS

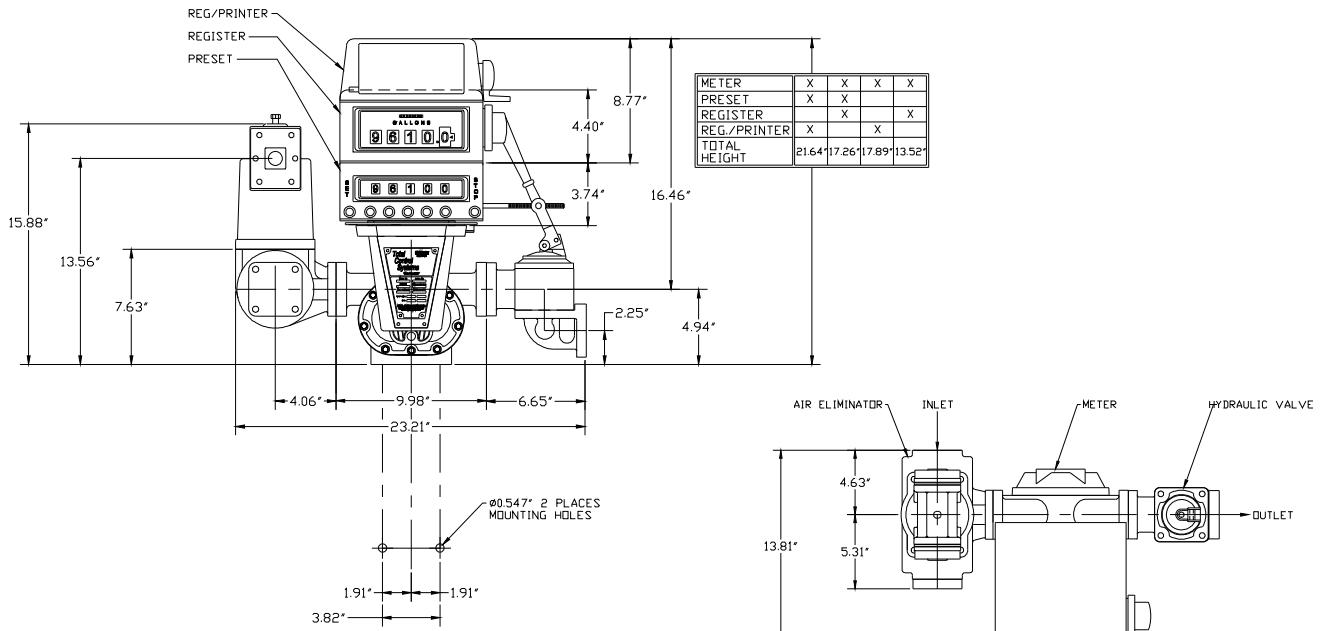

700-15 NET WEIGHTS IN POUNDS (KILOGRAMS)

Meter Type	Flow Meter	Register Counter	Preset Counter	Ticket Printer	Air Eliminator/ Strainer	Strainer	Electronic Valve	Mechanical Valve
SP	21 (9.5)	12 (5.4)	10 (4.5)	12 (5.4)	17 (7.7)	9 (4.1)	13 (5.9)	7 (3.2)
SPA	21 (9.5)	12 (5.4)	10 (4.5)	12 (5.4)	17 (7.7)	9 (4.1)	13 (5.9)	7 (3.2)
IP	21 (9.5)	12 (5.4)	10 (4.5)	12 (5.4)	17 (7.7)	9 (4.1)	13 (5.9)	7 (3.2)
IC	21 (9.5)	12 (5.4)	10 (4.5)	12 (5.4)	17 (7.7)	9 (4.1)	13 (5.9)	7 (3.2)

WARRANTY

Total Control Systems 700 rotary meters and accessory components sold to the original purchaser for a period of TWELVE (12) months from installation or EIGHTEEN (18) months from the date of shipment, to be free, under normal use and service, from defects in material and workmanship. If a warranty dispute occurs the DISTRIBUTOR may be required to provide proof of date of sale. Defects occurring within the stated warranty period, will be repaired or replaced, at TCS's option; provided that part or parts are returned to TCS transportation changes prepaid, and TCS's examination discloses the parts or workmanship to have been defective upon delivery to the purchaser. All repaired or warranted meters will be shipped Ex-works Fort Wayne, Indiana. Total Control Systems shall not be liable for consequential damages, whether or not arising out of warranty, negligence or otherwise.

NOTE: The above warranty applies only to Total Control Systems, Fort Wayne, Indiana manufactured products. Private label and OEM engineered products are specifically excluded from the above warranty. Consult factory for non-TCS manufacturer's warranty.



TOTAL CONTROL SYSTEMS
2515 Charleston Place
Fort Wayne, Indiana 46808 USA
(800) 348-4753 • (260) 484-0382
Fax: (260) 484-9230
sales@tcsmeters.com • www.tcsmeters.com



"Made in the U.S.A."

SPECIFICATIONS

700-20 Flow Meter

TOTAL CONTROL SYSTEMS



Total Control Systems rotary positive displacement flow meters offer reliable and precise measurement solutions for preset delivery, flow rate control, blending and custody transfer of vehicle or wholesale measurement applications.

INDUSTRIES SERVED

- Petroleum Products
- Alternative Fuels
- Aviation Fuels
- Agricultural Chemicals
- Petrochemicals
- Textiles
- Foods and Beverages
- Paints and Coatings
- Pharmaceuticals
- Printing Inks

DESIGN

The 700-20 flow meter has a simple and efficient meter design consisting of a housing and three rotors that rotate in unison within the measuring chamber. The absence of wear, from no metal-to-metal contact inside the chamber, eliminates any deterioration in accuracy and provides a long service life. The rotors are supported by bearings inserted into two bearing plates, where at the end of each rotor shaft is a timing gear. The timed rotation between each rotor is then transferred through the calibration adjuster to the register, which will then give a consistent and superior measurement of accuracy.



FLOW ILLUSTRATION

PERFORMANCE FEATURES

LOW PRESSURE DROP: will operate on gravity flow or pump pressure

SUSTAINED ACCURACY: no metal-to-metal contact inside the measuring chamber means minimal wear and deterioration in accuracy over time, fewer recalibrations and longer service life.

VISCOSITY RANGE: will accurately measure liquids up to 1,500,000 SSU (325,000 CPS)

LINEARITY:

5:1 Turndown - capable of $\pm 0.10\%$ of maximum nominal flow rate

10:1 Turndown - capable of $\pm 0.15\%$ of maximum nominal flow rate

REPEATABILITY: capable of 0.02% over the entire range of flow

Data provided from test conditions where all system variables were constant. The results are based on the 700 series flow meter and Veeder Root mechanical registration, using 32 SSU testing fluid.

REGULATORY: meets NIST, USA military and other international weights and measures accuracy requirements.

OPERATING SPECIFICATIONS

DESIGN TYPE: Positive Displacement Rotary Abutment

FLOW CAPACITY: 10 GPM to 100 GPM
38 LPM to 380 LPM

VISCOSITY: Up to 1,500,000 SSU (325,000 CPS)

PRESSURE RATING: 150 PSI
10.5 BAR

TEMPERATURE RATING: -40°F to 160°F
-40°C to 71°C

CONNECTIONS: 2" NPT Standard, 1-1/2" Optional. BSPT, Slip Weld, ANSI and DIN flanges are available upon request.

METER TYPES

SP Standard Petroleum

For metering refined petroleum products such as Leaded and Unleaded Gasoline, Fuel Oils, Diesel, Bio-Diesel, Kerosene, Jet Fuels, Vegetable Oils, Motor Oils, Ethylene Glycol (Anti-Freeze), etc.

SPA Standard Petroleum (Aviation)

For metering refined petroleum products; such as Regular and Unleaded Gasoline, Diesel, Bio-Diesel, Aviation Gasoline, Jet Fuel, Naptha, Kerosene, etc.

SPD Standard Petroleum (Ductile Iron)

For metering refined petroleum products; such as Ethanol, Methanol, Regular and Unleaded

Gasoline, Diesel, Bio-Diesel, Natural Gasoline, Vegetable Oil, Kerosene, etc.

IP Industrial Products

For metering Food Processing Liquids, Industrial Chemicals, General Solvents and many other liquids; such as Liquid Sugars, Corn Syrup, Soy Bean Oil, Shortenings, Latex Products, Adhesives, etc.

IC Industrial Products (Carbon Graphite)

For metering Industrial Chemicals, General Solvents, Water and other Non-Lubricating Liquids, such as Alcohol, Acetones, Ethanol, Naphtha, Xylene, MEK, Toluene, Deionized Water, Demineralized Water, Potable Water, etc.

AF All-Ferrous

For metering Pesticides, Fertilizers, Chemicals, Chlorinated Solvents, Agricultural Chemicals, Paints, Ink, Alkaline pH Latex Products, Adhesives, Liquid Feeds, etc.

SS Stainless Steel

For metering the same products as the SP, SPA, SPD, IP, IC and AF models but includes special handling liquids; such as Acids, Anti-Icing Fluids, Vinegar, Fruit Juices, etc.

MATERIALS OF CONSTRUCTION

Meter Type	Housing	Rotors	Bearing Plates	Bearing Sleeves	Journals	Timing Gears	Internal Hardware	Seals
SP	Anodized Aluminum	Anodized Aluminum	Ni-Resist	Ni-Resist	Hardchrome Stainless Steel	Stainless Steel	Stainless Steel	Viton ®
SPA	Anodized Aluminum	Anodized Aluminum	Ni-Resist	Carbon Graphite	Hardchrome Stainless Steel	Stainless Steel	Stainless Steel	Viton ®
SPD	Ductile Iron	Ni-Resist	Ni-Resist	Carbon Graphite	Hardchrome Stainless Steel	Stainless Steel	Stainless Steel	Teflon ® & Simriz ®
IP	Anodized Aluminum	Anodized Aluminum	Stainless Steel	Non-galling Illium 88 SS	Hardchrome Stainless Steel	Stainless Steel	Stainless Steel	Teflon ® & Simriz ®
IC	Anodized Aluminum	Anodized Aluminum	Ni-Resist	Carbon Graphite	Hardchrome Stainless Steel	Stainless Steel	Stainless Steel	Teflon ® & Simriz ®
AF	Ductile Iron	Stainless Steel	Stainless Steel	Carbon Graphite	Hardchrome Stainless Steel	Stainless Steel	Stainless Steel	Teflon ® & Simriz ®
SS	Stainless Steel	Stainless Steel	Stainless Steel	Carbon Graphite	Hardchrome Stainless Steel	Stainless Steel	Stainless Steel	Teflon ® & Simriz ®

Viton is a registered trademark of E.I. Dupont de Nemours & Co.

Teflon is a registered trademark of Dupont Dow Elastomers

Simriz is a registered trademark of Freudenberg-NOK

www.petroind.com

REGISTRATION OPTIONS

COUNTER REGISTER

Liquid measurement volume indication, using a 5 digit large numeral reset display and an 8 digit non-reset totalizer. Electronic or mechanical meter counter register is available. U.S. or Imperial Gallons, Liters, Dekaliter, Barrels, pounds, etc.

COUNTER PRESET

Select predetermined volume for precise batch control, utilizing preset control valve. Mechanical or electronic preset counters or batch controllers are available.

TICKET PRINTER

Provides an imprinted ticket record of each delivery transaction. Accumulative or Zero-Start, Face down or Face Up mechanical ticket printers available. Electronic slip or roll printers available for use with various electronic registration.

ELECTRONIC METER REGISTER

Digital liquid measurement volume indication that offers multiple functions to enhance the flow meter's accuracy and accountability. Most electronic registration are available with rate of flow indication, pulse output, valve control, RS232 and RS485 communication, currency and temperature compensation.

PULSE TRANSMITTER

The electronic pulse signal output converts the register counter volume per unit value into an electrical pulse stream. The electronic pulse stream can be transmitted to other electronic controllers for rate of flow, volume indication, additive injection or data acquisition.

TEMPERATURE COMPENSATION

Automatically corrects changes in volume caused by liquid temperature variations, during metered delivery. Normally corrects net volume or mass to 60°F (15°C) based on the product's coefficient of expansion, API or specific gravity.

MICROSWITCH

Mechanical signal from the Veeder Root preset counter converted into an electrical or pneumatic signal to provide control of remotely located valve, pump, and other system related equipment.

COUNTER EXTENSION

Raises the elevation of the counter registration for easy visibility or to protect from high temperatures. Counter Extension is required for temperatures more than 180°C (82°C).

RATE OF FLOW INDICATOR

Mechanical or digital indicator displays the volume at which the liquid is flowing through the flow meter.

SWIVEL

Allows mechanical registration to be rotated 360°. Designed for the Veeder Root counter register and ticket printer only.

METER ACCESSORIES

AIR ELIMINATOR

A float and reed valve operated design senses and removes free air or vapor before it can enter the flow meter. Required for custody transfer applications to ensure the most precise measurement.



ELECTRONIC PRESET VALVE

A normally closed two-stage piston preset valve for use with electronic relay control. The solenoid valves are available in 12 or 24 VDC, or 110 VAC coils. Stainless steel or brass pilot valves are also available. Dimensionally interchangeable with the mechanical valve.



STRAINER

A 90° strainer provides protection from debris entering into the flow meter. Must be mounted in vertical position when assembled with air eliminator. Stainless steel screens are available in 40, 80, 100 & 200 mesh, and 0.050 perforation.



PNEUMATIC PRESET VALVE

Air actuated, normally closed two-stage piston preset valve for use in systems with air supply. Dimensionally interchangeable with the mechanical valve.



HIGH CAPACITY STRAINER

An offset 90° strainer and air eliminator assembly designed for use in applications where a high volume of free air may potentially enter the measurement system. Recommended for mobile fuel delivery systems to pass product depletion (split compartment) testing.



AIR CHECK VALVE

The spring loaded check valve provides 15 PSI differential pressure to increase air eliminator efficiency and to prevent metering compressed air produced by a positive displacement pump during a stripping operation of the vessel being emptied.



MECHANICAL PRESET VALVE

A normally closed, hydraulically balanced piston control valve allows for auto-batch preset deliveries. The right angle, two-stage control valve is mechanically linked to Veeder Root Preset Counter.



WAFER CHECK VALVE

In-line check valve is mounted between the strainer and meter assembly to help increase air eliminator efficiency by creating additional back pressure.



ASSEMBLY COMBINATIONS

GROUP COMBINATIONS

- 2 **Meter & Register**
- 3 **Meter, Register & Ticket Printer**
- 4 **Meter, Register, Air Eliminator & Strainer**
- 4R **Meter, Register, Air Eliminator & High Volume Strainer**
- 5 **Meter, Register & Strainer**
- 6 **Meter, Register, Ticket Printer, Air Eliminator & Strainer**
- 6R **Meter, Register, Ticket Printer, Air Eliminator & High Volume Strainer**
- 7 **Meter, Register, Printer, & Strainer**
- 8 **Meter, Register, Preset & Valve**
- 9 **Meter, Register, Ticket Printer, Preset & Valve**
- 10 **Meter, Register, Preset, Valve, Air Eliminator & Strainer**
- 10R **Meter, Register, Preset, Valve, Air Eliminator & High Volume Strainer**
- 11 **Meter, Register, Ticket Printer, Preset, Valve, Air Eliminator & Strainer**
- 11R **Meter, Register, Ticket Printer, Preset, Valve, Air Eliminator & High Volume Strainer**
- 12 **Meter, Register, Preset, Valve & Strainer**
- 13 **Meter, Register, Ticket Printer, Preset, Valve & Strainer**

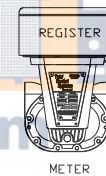
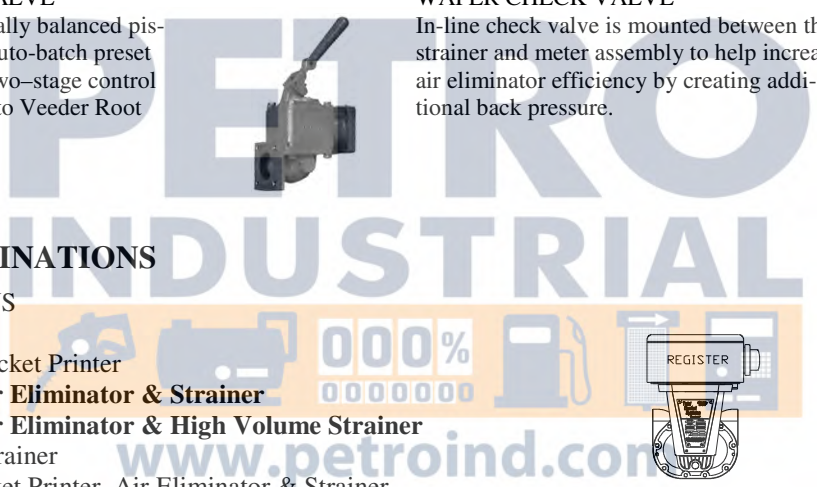

GROUP 2

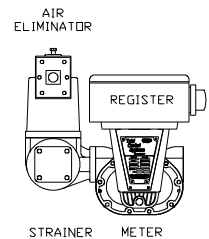

GROUP 4

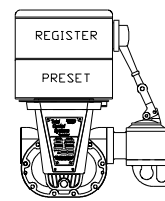

GROUP 8

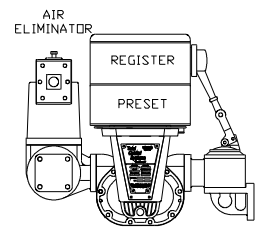

GROUP 10

METER ORIENTATION

- A **Meter Assembly with Veeder Root Registration**
- B **Meter assembly less Veeder Root Registration**
- C **Meter Assembly for use with Electronic Registration (less calibration adjuster)**
- D **Meter Assembly with direct drive pulse transmitter**



Meter A
(700-20SP10AT)



Meter B
(700-20SP10RBX)



Meter C
(700-20SP10RCXA)



Meter D
(700-30SP2DX)

700-20 DIMENSIONS

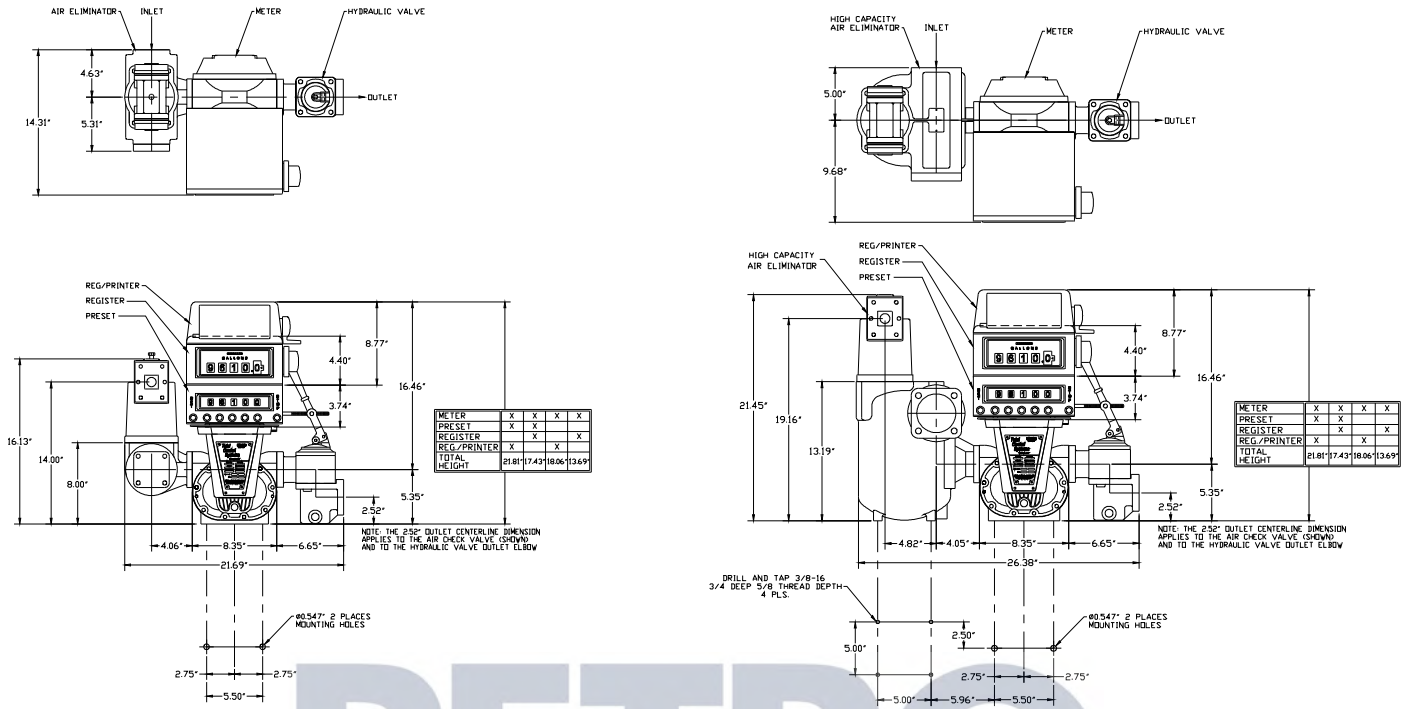

700-20 NET WEIGHTS IN POUNDS (KILOGRAMS)

Meter Type	Flow Meter	Register Counter	Preset Counter	Ticket Printer	Air Eliminator/ Strainer	Air Eliminator/ High Volume Strainer	Strainer	Electronic Valve	Mechanical Valve	Air Check Valve
SP	24 (11.8)	12 (5.4)	10 (4.5)	12 (5.4)	17 (7.7)	32 (14.5)	9 (4.1)	13 (5.9)	7 (3.2)	7 (3.2)
SPA	24 (11.8)	12 (5.4)	10 (4.5)	12 (5.4)	17 (7.7)	32 (14.5)	9 (4.1)	13 (5.9)	7 (3.2)	7 (3.2)
SPD	52 (22.7)	12 (5.4)	10 (4.5)	12 (5.4)	39 (17.8)	N/A	19 (8.6)	18 (8.2)	16 (7.3)	N/A
IP	24 (11.8)	12 (5.4)	10 (4.5)	12 (5.4)	17 (7.7)	N/A	9 (4.1)	13 (5.9)	7 (3.2)	N/A
IC	24 (11.8)	12 (5.4)	10 (4.5)	12 (5.4)	17 (7.7)	N/A	9 (4.1)	13 (5.9)	7 (3.2)	N/A
AF	52 (22.7)	12 (5.4)	10 (4.5)	12 (5.4)	39 (17.8)	N/A	19 (8.6)	18 (8.2)	16 (7.3)	N/A
SS	54 (22.7)	12 (5.4)	10 (4.5)	12 (5.4)	45 (20.4)	N/A	21 (9.5)	N/A	16 (7.3)	N/A

WARRANTY

Total Control Systems 700 rotary meters and accessory components sold to the original purchaser for a period of TWELVE (12) months from installation or EIGHTEEN (18) months from the date of shipment, to be free, under normal use and service, from defects in material and workmanship. If a warranty dispute occurs the DISTRIBUTOR may be required to provide proof of date of sale. Defects occurring within the stated warranty period, will be repaired or replaced, at TCS's option; provided that part or parts are returned to TCS transportation charges prepaid, and TCS's examination discloses the parts or workmanship to have been defective upon delivery to the purchaser. All repaired or warranted meters will be shipped Ex-works Fort Wayne, Indiana. Total Control Systems shall not be liable for consequential damages, whether or not arising out of warranty, negligence or otherwise.

NOTE: The above warranty applies only to Total Control Systems, Fort Wayne, Indiana manufactured products. Private label and OEM engineered products are specifically excluded from the above warranty. Consult factory for non-TCS manufacturer's warranty.



TOTAL CONTROL SYSTEMS
 2515 Charleston Place
 Fort Wayne, Indiana 46808 USA
 (800) 348-4753 • (260) 484-0382
 Fax: (260) 484-9230
 sales@tcsimeters.com • www.tcsimeters.com



"Made in the U.S.A."

SPECIFICATIONS

700-25 Flow Meter

TOTAL CONTROL SYSTEMS



Total Control Systems rotary positive displacement flow meters offer reliable and precise measurement solutions for preset delivery, flow rate control, blending and custody transfer of vehicle or wholesale measurement applications.

INDUSTRIES SERVED

- Petroleum Products
- Alternative Fuels
- Aviation Fuels
- Agricultural Chemicals
- Petrochemicals
- Textiles
- Foods and Beverages
- Paints and Coatings
- Pharmaceuticals
- Printing Inks

DESIGN

The 700-25 flow meter has a simple and efficient meter design consisting of a housing and three rotors that rotate in unison within the measuring chamber. The absence of wear, from no metal-to-metal contact inside the chamber, eliminates any deterioration in accuracy and provides a long service life. The rotors are supported by bearings inserted into two bearing plates, where at the end of each rotor shaft is a timing gear. The timed rotation between each rotor is then transferred through the calibration adjuster to the register, which will then give a consistent and superior measurement of accuracy.



FLOW ILLUSTRATION

PERFORMANCE FEATURES

LOW PRESSURE DROP: will operate on gravity flow or pump pressure

SUSTAINED ACCURACY: no metal-to-metal contact inside the measuring chamber means minimal wear and deterioration in accuracy over time, fewer recalibrations and longer service life.

VISCOSITY RANGE: will accurately measure liquids up to 1,500,000 SSU (325,000 CPS)

LINEARITY:

5:1 Turndown - capable of $\pm 0.100\%$ of maximum nominal flow rate

10:1 Turndown - capable of $\pm 0.125\%$ of maximum nominal flow rate

15:1 Turndown - capable of $\pm 0.150\%$ of maximum nominal flow rate

REPEATABILITY: capable of 0.02% over the entire range of flow

Data provided from test conditions where all system variables were constant. The results are based on the 700 series flow meter and Veeder Root mechanical registration, using 32 SSU testing fluid.

REGULATORY: Meets NIST, USA military and other international weights and measures accuracy requirements.

OPERATING SPECIFICATIONS

DESIGN TYPE: Positive Displacement Rotary Abutment

FLOW CAPACITY: 10 GPM to 150 GPM
38 LPM to 567 LPM

VISCOSITY: Up to 225 SSU at rated capacity.

PRESSURE RATING: 150 PSI
10.5 BAR

TEMPERATURE RATING: -40°F to 160°F
-40°C to 71°C

CONNECTIONS: 2" NPT Standard. Optional BSPT, Slip Weld, ANSI and DIN flanges are available upon request..

METER TYPES

SPA Standard Petroleum (Aviation)

For metering refined petroleum products; such as Regular and Unleaded Gasoline, Diesel, Bio-Diesel, Aviation Gasoline, Jet Fuel, Naptha, Kerosene, etc.

SPD Standard Petroleum (Ductile Iron)

For metering refined petroleum products; such as Ethanol, Methanol, Regular and Unleaded Gasoline, Diesel, Bio-Diesel, Natural Gasoline, Vegetable Oils, Kerosene, etc.

MATERIALS OF CONSTRUCTION

Meter Type	Housing	Rotors	Bearing Plates	Bearing Sleeves	Journals	Timing Gears	Internal Hardware	Seals
SPA	Anodized Aluminum	Anodized Aluminum	Ni-Resist	Carbon Graphite	Hardchrome Stainless Steel	Stainless Steel	Stainless Steel	Viton ®
SPD	Ductile Iron	Stainless Steel	Ni-Resist	Carbon Graphite	Hardchrome Stainless Steel	Stainless Steel	Stainless Steel	Teflon ® & Simriz ®

Viton is a registered trademark of E.I. Dupont de Nemours & Co.

Teflon is a registered trademark of Dupont Dow Elastomers

Simriz is a registered trademark of Freudenberg-NOK

REGISTRATION OPTIONS

COUNTER REGISTER

Liquid measurement volume indication, using a 5 digit large numeral reset display and an 8 digit non-reset totalizer. Electronic or mechanical meter counter register is available. U. S. or Imperial Gallons, Liters, Dekaliter, Barrels, pounds, etc.

COUNTER PRESET

Select predetermined volume for precise batch control, utilizing preset control valve. Mechanical or electronic preset counters or batch controllers are available.

TICKET PRINTER

Provides an imprinted ticket record of each delivery transaction. Accumulative or Zero-Start, Face down or Face Up mechanical ticket printers available. Electronic slip or roll printers available for use with various electronic registration.

ELECTRONIC METER REGISTER

Digital liquid measurement volume indication that offers multiple functions to enhance the flow meter's accuracy and accountability. Most electronic registration are available with rate of flow indication, pulse output, valve control, RS232 and RS485 communication, currency and temperature compensation.

PULSE TRANSMITTER

The electronic pulse signal output converts the register counter volume per unit value into a electrical pulse stream. The electronic pulse stream can be transmitted to other electronic controllers for rate of flow, volume indication, additive injection or data acquisition.

TEMPERATURE COMPENSATION

Automatically corrects changes in volume caused by liquid temperature variations, during metered delivery. Normally corrects net volume or mass to 60°F (15°C) based on the product's coefficient of expansion, API or specific gravity.

MICROSWITCH

Mechanical signal from the Veeder Root preset counter converted into an electrical or pneumatic signal to provide control of remotely located valve, pump, and other system related equipment.

COUNTER EXTENSION

Raises the elevation of the counter registration for easy visibility or to protect from high temperatures. Counter Extension is required for temperatures more than 180°C (82°C).

RATE OF FLOW INDICATOR

Mechanical or digital indicator displays the volume at which the liquid is flowing through the flow meter.

SWIVEL

Allows mechanical registration to be rotated 360°. Designed for the Veeder Root counter register and ticket printer only.

METER ACCESSORIES

AIR ELIMINATOR

A float and reed valve operated design senses and removes free air or vapor before it can enter the flow meter. Required for custody transfer applications to ensure the most precise measurement.



ELECTRONIC PRESET VALVE

A normally closed two-stage piston preset valve for use with electronic relay control. The solenoid valves are available in 12 or 24 VDC, or 110 VAC coils. Stainless steel or brass pilot valves are also available. Dimensionally interchangeable with the mechanical valve.



STRAINER

A 90° strainer provides protection from debris entering into the flow meter. Must be mounted in vertical position when assembled with air eliminator. Stainless steel screens are available in 40, 80, 100 & 200 mesh, and 0.050 perforation.



PNEUMATIC PRESET VALVE

Air actuated, normally closed two-stage piston preset valve for use in systems with air supply. Dimensionally interchangeable with the mechanical valve.



HIGH CAPACITY STRAINER

An offset 90° strainer and air eliminator assembly designed for use in applications where a high volume of free air may potentially enter the measurement system. Recommended for mobile fuel delivery systems to pass product depletion (split compartment) testing.



AIR CHECK VALVE

The spring loaded check valve provides 15 PSI differential pressure to increase air eliminator efficiency and to prevent metering compressed air produced by a positive displacement pump during a stripping operation of the vessel being emptied.



MECHANICAL PRESET VALVE

A normally closed, hydraulically balanced piston control valve allows for auto-batch preset deliveries. The right angle, two-stage control valve is mechanically linked to Veeder Root Preset Counter.



WAFER CHECK VALVE

In-line check valve is mounted between the strainer and meter assembly to help increase air eliminator efficiency by creating additional back pressure.



ASSEMBLY COMBINATIONS

GROUP COMBINATIONS

- 2 Meter & Register
- 3 Meter, Register & Ticket Printer
- 4 Meter, Register, Air Eliminator & Strainer
- 4R Meter, Register, Air Eliminator & High Volume Strainer
- 5 Meter, Register & Strainer
- 6 Meter, Register, Ticket Printer, Air Eliminator & Strainer
- 6R Meter, Register, Ticket Printer, Air Eliminator & High Volume Strainer
- 7 Meter, Register, Printer, & Strainer
- 8 Meter, Register, Preset & Valve
- 9 Meter, Register, Ticket Printer, Preset & Valve
- 10 Meter, Register, Preset, Valve, Air Eliminator & Strainer
- 10R Meter, Register, Preset, Valve, Air Eliminator & High Volume Strainer
- 11 Meter, Register, Ticket Printer, Preset, Valve, Air Eliminator & Strainer
- 11R Meter, Register, Ticket Printer, Preset, Valve, Air Eliminator & High Volume Strainer
- 12 Meter, Register, Preset, Valve & Strainer
- 13 Meter, Register, Ticket Printer, Preset, Valve & Strainer

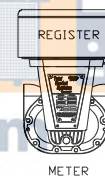

GROUP 2

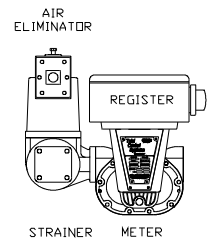

GROUP 4

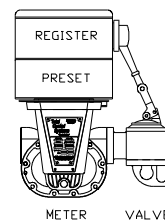

GROUP 8

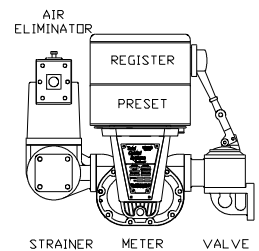

GROUP 10

METER ORIENTATION

- A Meter Assembly with Veeder Root Registration
- B Meter assembly less Veeder Root Registration
- C Meter Assembly for use with Electronic Registration (less calibration adjuster)
- D Meter Assembly with direct drive pulse transmitter



Meter A
(700-20SP10AT)



Meter B
(700-20SP10RBX)



Meter C
(700-20SP10RCXA)



Meter D
(700-30SP2DX)

700-25 DIMENSIONS

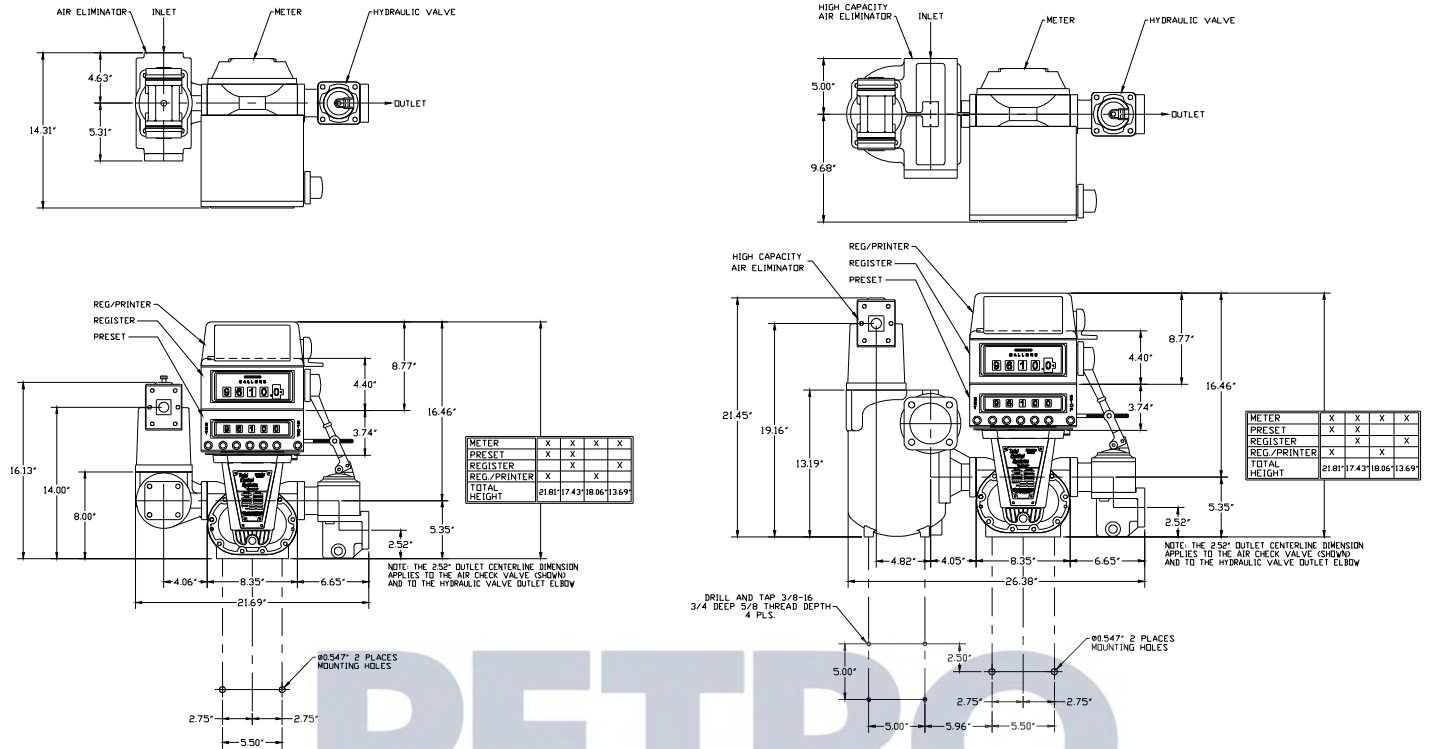

700-25 NET WEIGHTS IN POUNDS (KILOGRAMS)

Meter Type	Flow Meter	Register Counter	Preset Counter	Ticket Printer	Air Eliminator/Strainer	Air Eliminator/High Volume Strainer	Strainer	Electronic Valve	Mechanical Valve	Air Check Valve
SPA	24 (11.8)	12 (5.4)	10 (4.5)	12 (5.4)	17 (7.7)	32 (14.5)	9 (4.1)	13 (5.9)	7 (3.2)	7 (3.2)
SPD	52 (22.7)	12 (5.4)	10 (4.5)	12 (5.4)	39 (17.8)	N/A	19 (8.6)	18 (8.2)	16 (7.3)	N/A

WARRANTY

Total Control Systems 700 rotary meters and accessory components sold to the original purchaser for a period of TWELVE (12) months from installation or EIGHTEEN (18) months from the date of shipment, to be free, under normal use and service, from defects in material and workmanship. If a warranty dispute occurs the DISTRIBUTOR may be required to provide proof of date of sale. Defects occurring within the stated warranty period, will be repaired or replaced, at TCS's option; provided that part or parts are returned to TCS transportation changes prepaid, and TCS's examination discloses the parts or workmanship to have been defective upon delivery to the purchaser. All repaired or warranted meters will be shipped Ex-works Fort Wayne, Indiana. Total Control Systems shall not be liable for consequential damages, whether or not arising out of warranty, negligence or otherwise.

NOTE: The above warranty applies only to Total Control Systems, Fort Wayne, Indiana manufactured products. Private label and OEM engineered products are specifically excluded from the above warranty. Consult factory for non-TCS manufacturer's warranty.



TOTAL CONTROL SYSTEMS
 2515 Charleston Place
 Fort Wayne, Indiana 46808 USA
 (800) 348-4753 • (260) 484-0382
 Fax: (260) 484-9230
 sales@tcsmeters.com • www.tcsmeters.com



"Made in the U.S.A."

SPECIFICATIONS

700-30 Flow Meter

TOTAL CONTROL SYSTEMS



Total Control Systems rotary positive displacement flow meters offer reliable and precise measurement solutions for preset delivery, flow rate control, blending and custody transfer of vehicle or wholesale measurement applications.

INDUSTRIES SERVED

- Petroleum Products
- Alternative Fuels
- Aviation Fuels
- Agricultural Chemicals
- Petrochemicals
- Textiles
- Foods and Beverages
- Paints and Coatings
- Pharmaceuticals
- Printing Inks

DESIGN

The 700-30 flow meter has a simple and efficient meter design consisting of a housing and three rotors that rotate in unison within the measuring chamber. The absence of wear, from no metal-to-metal contact inside the chamber, eliminates any deterioration in accuracy and provides a long service life. The rotors are supported by bearings inserted into two bearing plates, where at the end of each rotor shaft is a timing gear. The timed rotation between each rotor is then transferred through the calibration adjuster to the register, which will then give a consistent and superior measurement of accuracy.



FLOW ILLUSTRATION

PERFORMANCE FEATURES

LOW PRESSURE DROP: will operate on gravity flow or pump pressure

SUSTAINED ACCURACY: no metal-to-metal contact inside the measuring chamber means minimal wear and deterioration in accuracy over time, fewer recalibrations and longer service life.

VISCOSITY RANGE: will accurately measure liquids up to 1,500,000 SSU (325,000 CPS)

LINEARITY:
5:1 Turndown - capable of $\pm 0.10\%$ of maximum nominal flow rate
10:1 Turndown - capable of $\pm 0.15\%$ of maximum nominal flow rate

REPEATABILITY: capable of 0.02% over the entire range of flow

Data provided from test conditions where all system variables were constant. The results are based on the 700 series flow meter and Veeder Root mechanical registration, using 32 SSU testing fluid.

REGULATORY: Meets NIST, USA military and other international weights and measures accuracy requirements.

OPERATING SPECIFICATIONS

DESIGN TYPE: Positive Displacement Rotary Abutment

FLOW CAPACITY: 20 GPM to 200 GPM
57 LPM to 760 LPM

VISCOSITY: Up to 1,500,000 (325,000 CPS)

PRESSURE RATING: 150 PSI
10.5 BAR

TEMPERATURE RATING: -40°F to 160°F
-40°C to 71°C

CONNECTIONS: 3" NPT Standard, 2" Optional. BSPT, Slip Weld, ANSI and DIN flanges are available upon request.

METER TYPES

SP Standard Petroleum

For metering refined petroleum products such as Leaded and Unleaded Gasoline, Fuel Oils, Diesel, Bio-Diesel, Kerosene, Jet Fuels, Vegetable Oils, Motor Oils, Ethylene Glycol (Anti-Freeze), etc.

SPA Standard Petroleum (Aviation)

For metering refined petroleum products; such as Aviation Gasoline, Jet Fuel, Regular and Unleaded Gasoline, Diesel, Bio-Diesel, Naptha, Kerosene, etc

SPD Standard Petroleum (Ductile Iron)

For metering refined petroleum products; such as Ethanol, Methanol, Regular and Unleaded Gasoline, Diesel, Bio-Diesel, Natural Gasoline, Vegetable Oil, Kerosene, etc.

IP Industrial Products

For metering Food Processing Liquids, Industrial Chemicals, General Solvents and many other liquids; such as Liquid Sugars, Corn Syrup, Soy Bean Oil, Shortenings, Latex Products, Adhesives, etc.

IC Industrial Products (Carbon Graphite)

For metering Industrial Chemicals, General Solvents, Water and other Non-Lubricating Liquids, such as Alcohol, Acetones, Ethanol, Naptha, Xylene, MEK, Toluene, Deionized Water, Demineralized Water, Potable Water, etc.

AF All-Ferrous

For metering Pesticides, Fertilizers, Chemicals, Chlorinated Solvents, Agricultural Chemicals, Paints, Ink, Alkaline pH Latex Products, Adhesives, Liquid Feeds, etc.

MATERIALS OF CONSTRUCTION

Meter Type	Housing	Rotors	Bearing Plates	Bearing Sleeves	Journals	Timing Gears	Internal Hardware	Seals
SP	Anodized Aluminum	Anodized Aluminum	Ni-Resist	Ni-Resist	Hardchrome Stainless Steel	Stainless Steel	Stainless Steel	Viton ®
SPA	Anodized Aluminum	Anodized Aluminum	Ni-Resist	Carbon Graphite	Hardchrome Stainless Steel	Stainless Steel	Stainless Steel	Viton ®
SPD	Ductile Iron	Ni-Resist	Ni-Resist	Carbon Graphite	Hardchrome Stainless Steel	Stainless Steel	Stainless Steel	Teflon ® & Simriz ®
IP	Anodized Aluminum	Anodized Aluminum	Stainless Steel	Non-galling Illium 88 SS	Hardchrome Stainless Steel	Stainless Steel	Stainless Steel	Teflon ® & Simriz ®
IC	Anodized Aluminum	Anodized Aluminum	Ni-Resist	Carbon Graphite	Hardchrome Stainless Steel	Stainless Steel	Stainless Steel	Teflon ® & Simriz ®
AF	Ductile Iron	Ni-Resist	Ni-Resist	Carbon Graphite	Hardchrome Stainless Steel	Stainless Steel	Stainless Steel	Teflon ® & Simriz ®

Viton is a registered trademark of E.I. Dupont de Nemours & Co.
Teflon is a registered trademark of Dupont Dow Elastomers
Simriz is a registered trademark of Freudenberg-NOK

REGISTRATION OPTIONS

COUNTER REGISTER

Liquid measurement volume indication, using a 5 digit large numeral reset display and an 8 digit non-reset totalizer. Electronic or mechanical meter counter register is available. U.S. or Imperial Gallons, Liters, Dekaliter, Barrels, pounds, etc.

COUNTER PRESET

Select predetermined volume for precise batch control, utilizing preset control valve. Mechanical or electronic preset counters or batch controllers are available.

TICKET PRINTER

Provides an imprinted ticket record of each delivery transaction. Accumulative or Zero-Start, Face down or Face Up mechanical ticket printers available. Electronic slip or roll printers available for use with various electronic registration.

ELECTRONIC METER REGISTER

Digital liquid measurement volume indication that offers multiple functions to enhance the flow meter's accuracy and accountability. Most electronic registration are available with rate of flow indication, pulse output, valve control, RS232 and RS485 communication, currency and temperature compensation.

PULSE TRANSMITTER

The electronic pulse signal output converts the register counter volume per unit value into a electrical pulse stream. The electronic pulse stream can be transmitted to other electronic controllers for rate of flow, volume indication, additive injection or data acquisition.

TEMPERATURE COMPENSATION

Automatically corrects changes in volume caused by liquid temperature variations, during metered delivery. Normally corrects net volume or mass to 60°F (15°C) based on the product's coefficient of expansion, API or specific gravity.

MICROSWITCH

Mechanical signal from the Veeder Root preset counter converted into an electrical or pneumatic signal to provide control of remotely located valve, pump, and other system related equipment.

COUNTER EXTENSION

Raises the elevation of the counter registration for easy visibility or to protect from high temperatures. Counter Extension is required for temperatures more than 180°C (82°C).

RATE OF FLOW INDICATOR

Mechanical or digital indicator displays the volume at which the liquid is flowing through the flow meter.

SWIVEL

Allows mechanical registration to be rotated 360°. Designed for the Veeder Root counter register and ticket printer only.

www.petroid.com

METER ACCESSORIES

AIR ELIMINATOR

A float and reed valve operated design senses and removes free air or vapor before it can enter the flow meter. Required for custody transfer applications to ensure the most precise measurement.



STRAINER

A 90° strainer provides protection from debris entering into the flow meter. Must be mounted in vertical position when assembled with air eliminator. Stainless steel screens are available in 40, 80, 100 & 200 mesh, and 0.050 perforation.



HIGH CAPACITY STRAINER

An offset 90° strainer and air eliminator assembly designed for use in applications where a high volume of free air may potentially enter the measurement system. Recommended for mobile fuel delivery systems to pass product depletion (split compartment) testing.



MECHANICAL PRESET VALVE

A normally closed, hydraulically balanced piston control valve allows for auto-batch preset deliveries. The right angle, two-stage control valve is mechanically linked to Veeder Root Preset Counter.



ELECTRONIC PRESET VALVE

A normally closed two-stage piston preset valve for use with electronic relay control. The solenoid valves are available in 12 or 24 VDC, or 110 VAC coils. Stainless steel or brass pilot valves are also available. Dimensionally interchangeable with the mechanical valve.



PNEUMATIC PRESET VALVE

Air actuated, normally closed two-stage piston preset valve for use in systems with air supply. Dimensionally interchangeable with the mechanical valve.



AIR CHECK VALVE

The spring loaded check valve provides 15 PSI differential pressure to increase air eliminator efficiency and to prevent metering compressed air produced by a positive displacement pump during a stripping operation of the vessel being emptied.



WAFER CHECK VALVE

In-line check valve is mounted between the strainer and meter assembly to help increase air eliminator efficiency by creating additional back pressure.



ASSEMBLY COMBINATIONS

GROUP COMBINATIONS

- 2 Meter & Register
- 3 Meter, Register & Ticket Printer
- 4 Meter, Register, Air Eliminator & Strainer
- 4R Meter, Register, Air Eliminator & High Volume Strainer
- 5 Meter, Register & Strainer
- 6 Meter, Register, Ticket Printer, Air Eliminator & Strainer
- 6R Meter, Register, Ticket Printer, Air Eliminator & High Volume Strainer
- 7 Meter, Register, Printer, & Strainer
- 8 Meter, Register, Preset & Valve
- 9 Meter, Register, Ticket Printer, Preset & Valve
- 10 Meter, Register, Preset, Valve, Air Eliminator & Strainer
- 10R Meter, Register, Preset, Valve, Air Eliminator & High Volume Strainer
- 11 Meter, Register, Ticket Printer, Preset, Valve, Air Eliminator & Strainer
- 11R Meter, Register, Ticket Printer, Preset, Valve, Air Eliminator & High Volume Strainer
- 12 Meter, Register, Preset, Valve & Strainer
- 13 Meter, Register, Ticket Printer, Preset, Valve & Strainer

METER ORIENTATION

- A Meter Assembly with Veeder Root Registration
- B Meter assembly less Veeder Root Registration
- C Meter Assembly for use with Electronic Registration (less calibration adjuster)
- D Meter Assembly with direct drive pulse transmitter



GROUP 2

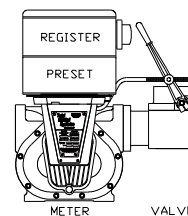

GROUP 8

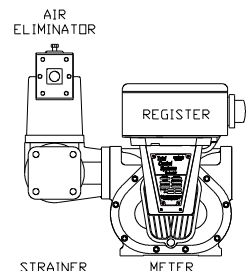

GROUP 4

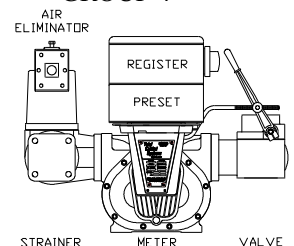

GROUP 10



Meter A
(700-20SP10AT)



Meter B
(700-20SP10RBX)



Meter C
(700-20SP10CXA)



Meter D
(700-30SP2DX)

700-30 DIMENSIONS

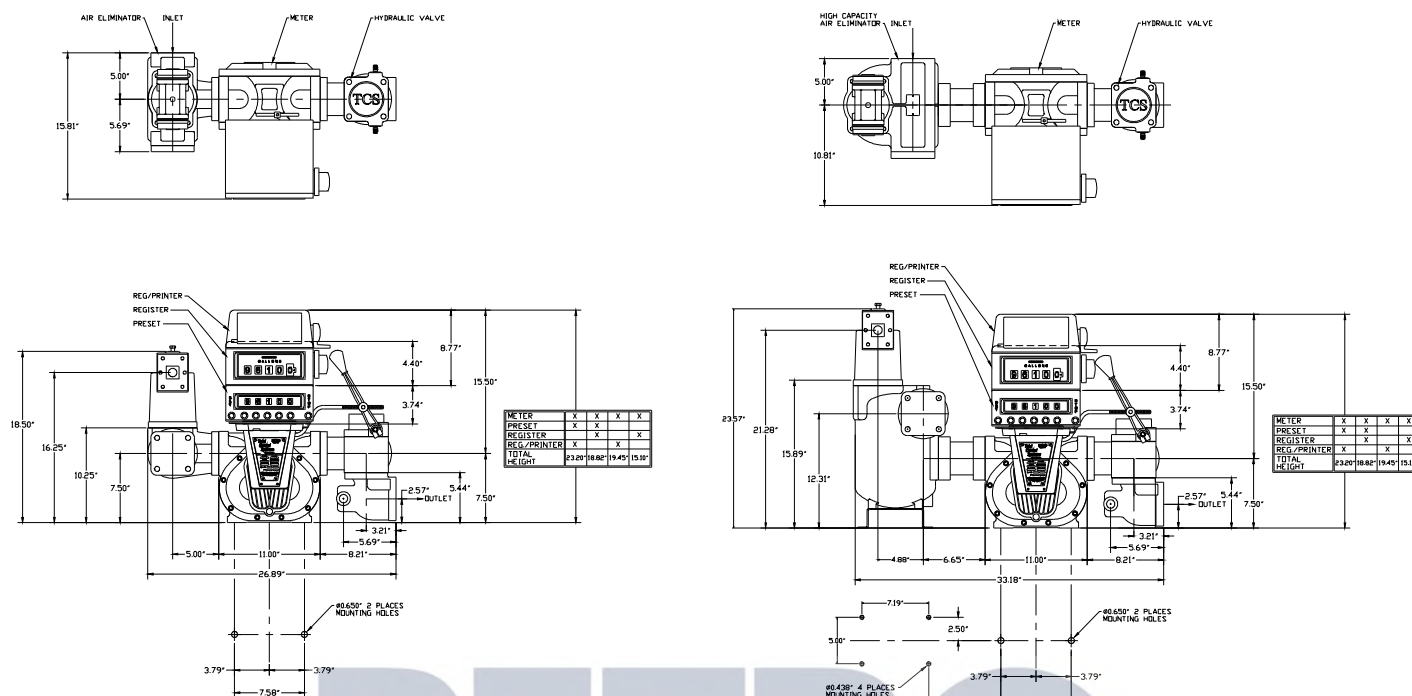

700-30 NET WEIGHTS IN POUNDS (KILOGRAMS)

Meter Type	Flow Meter	Register Counter	Preset Counter	Ticket Printer	Air Eliminator/ Strainer	Air Eliminator/ High Volume Strainer	Strainer	Electronic Valve	Mechanical Valve	Air Check Valve
SP	53 (24.0)	12 (5.4)	10 (4.5)	12 (5.4)	20 (9.1)	37 (16.8)	13 (5.9)	17 (7.7)	12 (5.4)	12 (5.4)
SPA	53 (24.0)	12 (5.4)	10 (4.5)	12 (5.4)	20 (9.1)	37 (16.8)	13 (5.9)	17 (7.7)	12 (5.4)	12 (5.4)
SPD	125 (56.7)	12 5.4	10 4.5	12 5.4	59 (26.8)	N/A	38 (17.2)	34 (15.4)	N/A	N/A
IP	125 (56.7)	12 5.4	10 4.5	12 5.4	59 (26.8)	N/A	38 (17.2)	34 (15.4)	12 (5.4)	12 (5.4)
IC	125 (56.7)	12 5.4	10 4.5	12 5.4	59 (26.8)	N/A	38 (17.2)	34 (15.4)	12 (5.4)	12 (5.4)
AF	125 (56.7)	12 5.4	10 4.5	12 5.4	59 (26.8)	N/A	38 (17.2)	34 (15.4)	N/A	N/A

WARRANTY

Total Control Systems 700 rotary meters and accessory components sold to the original purchaser for a period of TWELVE (12) months from installation or EIGHTEEN (18) months from the date of shipment, to be free, under normal use and service, from defects in material and workmanship. If a warranty dispute occurs the DISTRIBUTOR may be required to provide proof of date of sale. Defects occurring within the stated warranty period, will be repaired or replaced, at TCS's option; provided that part or parts are returned to TCS transportation changes prepaid, and TCS's examination discloses the parts or workmanship to have been defective upon delivery to the purchaser. All repaired or warranted meters will be shipped Ex-works Fort Wayne, Indiana. Total Control Systems shall not be liable for consequential damages, whether or not arising out of warranty, negligence or otherwise.

NOTE: The above warranty applies only to Total Control Systems, Fort Wayne, Indiana manufactured products. Private label and OEM engineered products are specifically excluded from the above warranty. Consult factory for non-TCS manufacturer's war-



TOTAL CONTROL SYSTEMS
 2515 Charleston Place
 Fort Wayne, Indiana 46808 USA
 (800) 348-4753 • (260) 484-0382
 Fax: (260) 484-9230
 sales@tcsimeters.com • www.tcsimeters.com



"Made in the U.S.A."

SPECIFICATIONS

700-40 Flow Meter

TOTAL CONTROL SYSTEMS



Total Control Systems rotary positive displacement flow meters offer reliable and precise measurement solutions for preset delivery, flow rate control, blending and custody transfer of vehicle or wholesale measurement applications.

INDUSTRIES SERVED

- Petroleum Products
- Alternative Fuels
- Aviation Fuels
- Agricultural Chemicals
- Petrochemicals
- Textiles
- Foods and Beverages
- Paints and Coatings
- Pharmaceuticals
- Printing Inks

DESIGN

The 700-40 flow meter has a simple and efficient meter design consisting of a housing and three rotors that rotate in unison within the measuring chamber. The absence of wear, from no metal-to-metal contact inside the chamber, eliminates any deterioration in accuracy and provides a long service life. The rotors are supported by bearings inserted into two bearing plates, where at the end of each rotor shaft is a timing gear. The timed rotation between each rotor is then transferred through the calibration adjuster to the register, which will then give a consistent and superior measurement of accuracy.



FLOW ILLUSTRATION

PERFORMANCE FEATURES

LOW PRESSURE DROP: will operate on gravity flow or pump pressure

SUSTAINED ACCURACY: no metal-to-metal contact inside the measuring chamber means minimal wear and deterioration in accuracy over time, fewer recalibrations and longer service life.

VISCOSITY RANGE: will accurately measure liquids up to 1,500,000 SSU (325,000 CPS)

LINEARITY:

- 5:1 Turndown - capable of $\pm 0.10\%$ of maximum nominal flow rate
- 12.5:1 Turndown - capable of $\pm 0.15\%$ of maximum nominal flow rate

REPEATABILITY: capable of 0.02% over the entire range of flow

Data provided from test conditions where all system variables were constant. The results are based on the 700 series flow meter and Veeder Root mechanical registration, using 32 SSU testing fluid.

REGULATORY: Meets NIST, USA military and other international weights and measures accuracy requirements.

OPERATING SPECIFICATIONS

DESIGN TYPE: Positive Displacement Rotary Abutment

FLOW CAPACITY: 40 GPM to 500 GPM
151 LPM to 1893 LPM

VISCOSITY: Up to 1,500,00 SSU (325,000 CPS)

PRESSURE RATING: 150 PSI
10.5 BAR

TEMPERATURE RATING: -40°F to 160°F
-40°C to 71°C

CONNECTIONS: 4" NPT Standard, 3" Optional. BSPT, Slip Weld, ANSI and DIN flanges are available upon request.

METER TYPES

SP Standard Petroleum

For metering refined petroleum products such as Leaded and Unleaded Gasoline, Fuel Oils, Diesel, Bio-Diesel, Kerosene, Jet Fuels, Vegetable Oils, Motor Oils, Ethylene Glycol (Anti-Freeze), etc.

SPA Standard Petroleum (Aviation)

For metering refined petroleum products; such as Aviation Gasoline, Jet Fuel, Regular and Unleaded Gasoline, Diesel, Bio-Diesel, Naptha, Kerosene, etc

SPD Standard Petroleum (Ductile Iron)

For metering refined petroleum products; such as Ethanol, Methanol, Regular and Unleaded Gasoline, Diesel, Bio-Diesel, Natural Gasoline, Vegetable Oil, Kerosene, etc.

IP Industrial Products

For metering Food Processing Liquids, Industrial Chemicals, General Solvents and many other liquids; such as Liquid Sugars, Corn Syrup, Soy Bean Oil, Shortenings, Latex Products, Adhesives, etc.

IC Industrial Products (Carbon Graphite)

For metering Industrial Chemicals, General Solvents, Water and other Non-Lubricating Liquids, such as Alcohol, Acetones, Ethanol, Naptha, Xylene, MEK, Toluene, Deionized Water, Demineralized Water, Potable Water, etc.

AF All-Ferrous

For metering Pesticides, Fertilizers, Chemicals, Chlorinated Solvents, Agricultural Chemicals, Paints, Ink, Alkaline pH Latex Products, Adhesives, Liquid Feeds, etc.

MATERIALS OF CONSTRUCTION

Meter Type	Housing	Rotors	Bearing Plates	Bearing Sleeves	Journals	Timing Gears	Internal Hardware	Seals
SP	Anodized Aluminum	Anodized Aluminum	Ni-Resist	Ni-Resist	Hardchrome Stainless Steel	Stainless Steel	Stainless Steel	Viton ®
SPA	Anodized Aluminum	Anodized Aluminum	Ni-Resist	Carbon Graphite	Hardchrome Stainless Steel	Stainless Steel	Stainless Steel	Viton ®
SPD	Ductile Iron	Ni-Resist	Ni-Resist	Carbon Graphite	Hardchrome Stainless Steel	Stainless Steel	Stainless Steel	Teflon ® & Simriz ®
IP	Anodized Aluminum	Anodized Aluminum	Stainless Steel	Non-galling Illium 88 SS	Hardchrome Stainless Steel	Stainless Steel	Stainless Steel	Teflon ® & Simriz ®
IC	Anodized Aluminum	Anodized Aluminum	Ni-Resist	Carbon Graphite	Hardchrome Stainless Steel	Stainless Steel	Stainless Steel	Teflon ® & Simriz ®
AF	Ductile Iron	Ni-Resist	Ni-Resist	Carbon Graphite	Hardchrome Stainless Steel	Stainless Steel	Stainless Steel	Teflon ® & Simriz ®

Viton is a registered trademark of E.I. Dupont de Nemours & Co.
Teflon is a registered trademark of Dupont Dow Elastomers
Simriz is a registered trademark of Freudenberg-NOK

www.petroind.com

REGISTRATION OPTIONS

COUNTER REGISTER

Liquid measurement volume indication, using a 5 digit large numeral reset display and an 8 digit non-reset totalizer. Electronic or mechanical meter counter register is available. U.S. or Imperial Gallons, Liters, Dekaliter, Barrels, pounds, etc.

COUNTER PRESET

Select predetermined volume for precise batch control, utilizing preset control valve. Mechanical or electronic preset counters or batch controllers are available.

TICKET PRINTER

Provides an imprinted ticket record of each delivery transaction. Accumulative or Zero-Start, Face down or Face Up mechanical ticket printers available. Electronic slip or roll printers available for use with various electronic registration.

ELECTRONIC METER REGISTER

Digital liquid measurement volume indication that offers multiple functions to enhance the flow meter's accuracy and accountability. Most electronic registration are available with rate of flow indication, pulse output, valve control, RS232 and RS485 communication, currency and temperature compensation.

PULSE TRANSMITTER

The electronic pulse signal output converts the register counter volume per unit value into an electrical pulse stream. The electronic pulse stream can be transmitted to other electronic controllers for rate of flow, volume indication, additive injection or data acquisition.

TEMPERATURE COMPENSATION

Automatically corrects changes in volume caused by liquid temperature variations, during metered delivery. Normally corrects net volume or mass to 60°F (15°C) based on the product's coefficient of expansion, API or specific gravity.

MICROSWITCH

Mechanical signal from the Veeder Root preset counter converted into an electrical or pneumatic signal to provide control of remotely located valve, pump, and other system related equipment.

COUNTER EXTENSION

Raises the elevation of the counter registration for easy visibility or to protect from high temperatures. Counter Extension is required for temperatures more than 180°C (82°C).

RATE OF FLOW INDICATOR

Mechanical or digital indicator displays the volume at which the liquid is flowing through the flow meter.

SWIVEL

Allows mechanical registration to be rotated 360°. Designed for the Veeder Root counter register and ticket printer only.

METER ACCESSORIES

AIR ELIMINATOR

A float and reed valve operated design senses and removes free air or vapor before it can enter the flow meter. Required for custody transfer applications to ensure the most precise measurement.



MECHANICAL PRESET VALVE

A normally closed, hydraulically balanced piston control valve allows for auto-batch preset deliveries. The right angle, two-stage control valve is mechanically linked to Veeder Root Preset Counter.



STRAINER

A 90° strainer provides protection from debris entering into the flow meter. Must be mounted in vertical position when assembled with air eliminator. Stainless steel screens are available in 40, 80, 100 & 200 mesh, and 0.050 perforation.



ELECTRONIC PRESET VALVE

A normally closed, two-stage diaphragm preset valve for use with electronic relay control. The solenoid valves are available in 12 or 24 VDC, or 110 VAC coils.



BULK AIR ELIMINATOR

A bulk air eliminator assembly is designed for use in applications where a high volume of free air may enter the measurement storage system. Available with single or dual SP, AF or SS air eliminators assembled to stainless steel vessel.



WAFER CHECK VALVE

In-line check valve is mounted between the strainer and meter assembly to help increase air eliminator efficiency by creating additional back pressure.



ASSEMBLY COMBINATIONS

GROUP COMBINATIONS

- 2 **Meter & Register**
- 3 Meter, Register & Ticket Printer
- 4 **Meter, Register, Air Eliminator & Strainer**
- 4R **Meter, Register, Air Eliminator & High Volume Strainer**
- 5 Meter, Register & Strainer
- 6 Meter, Register, Ticket Printer, Air Eliminator & Strainer
- 6R Meter, Register, Ticket Printer, Air Eliminator & High Volume Strainer
- 7 Meter, Register, Printer, & Strainer
- 8 **Meter, Register, Preset & Valve**
- 9 Meter, Register, Ticket Printer, Preset & Valve
- 10 **Meter, Register, Preset, Valve, Air Eliminator & Strainer**
- 10R **Meter, Register, Preset, Valve, Air Eliminator & High Volume Strainer**
- 11 Meter, Register, Ticket Printer, Preset, Valve, Air Eliminator & Strainer
- 11R Meter, Register, Ticket Printer, Preset, Valve, Air Eliminator & High Volume Strainer
- 12 Meter, Register, Preset, Valve & Strainer
- 13 Meter, Register, Ticket Printer, Preset, Valve & Strainer

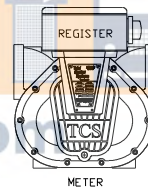

GROUP 2

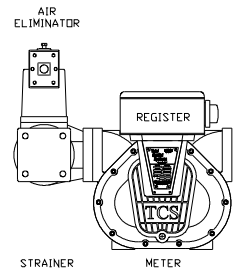

GROUP 4

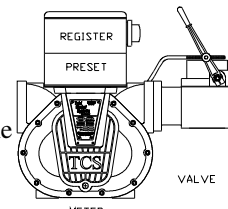

GROUP 8

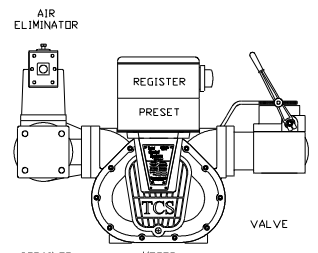

GROUP 10

METER ORIENTATION

- A Meter Assembly with Veeder Root Registration
- B Meter assembly less Veeder Root Registration
- C Meter Assembly for use with Electronic Registration (less calibration adjuster)
- D Meter Assembly with direct drive pulse transmitter



Meter A
(700-20SP10AT)



Meter B
(700-20SP10RBX)



Meter C
(700-20SP10CXA)



Meter D
(700-30SP2DX)

700-40 DIMENSIONS

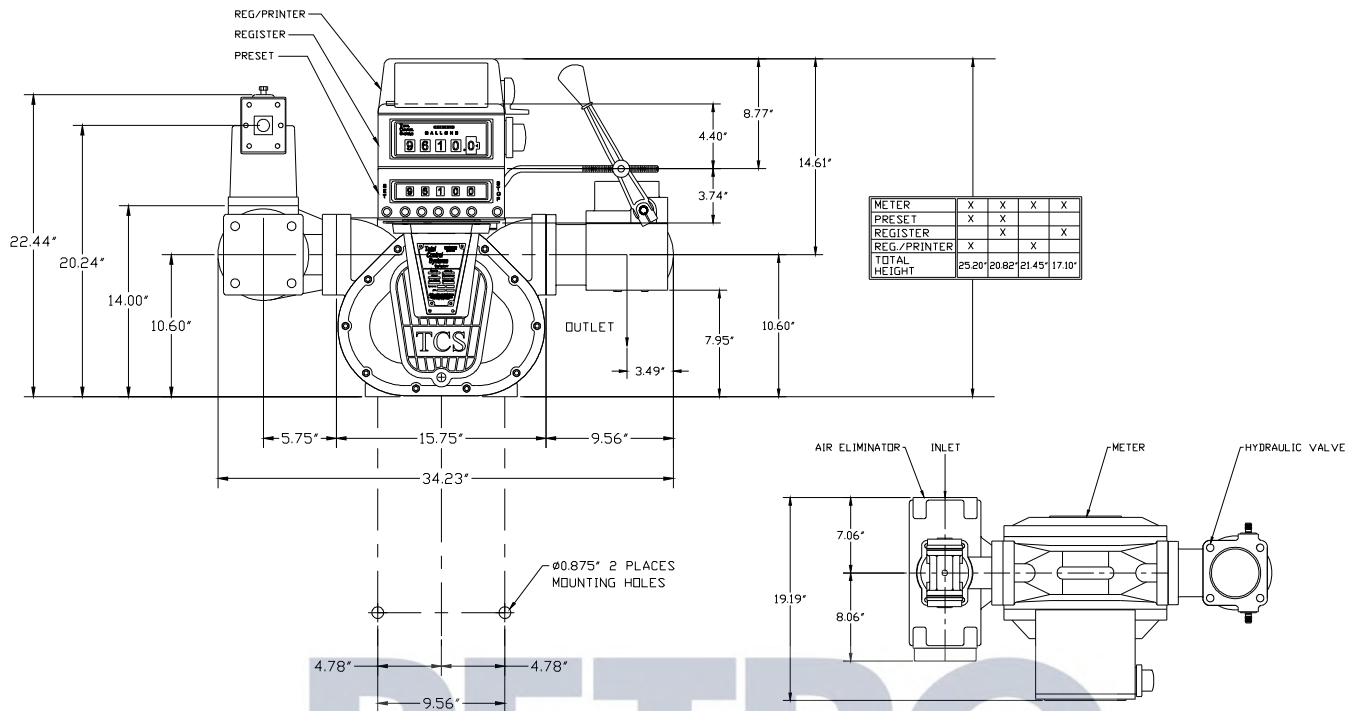

700-40 NET WEIGHTS IN POUNDS (KILOGRAMS)

Meter Type	Flow Meter	Register Counter	Preset Counter	Ticket Printer	Air Eliminator/ Strainer	Bulk Air Eliminator	Strainer	Electronic Valve	Mechanical Valve
SP	110 (49.9)	12 (5.4)	10 (4.5)	12 (5.4)	32 (14.5)	134 (60.8)	25 (11.3)	Consult Factory	17 (7.7)
SPA	110 (49.9)	12 (5.4)	10 (4.5)	12 (5.4)	32 (14.5)	134 (60.8)	25 (11.3)	Consult Factory	17 (7.7)
SPD	275 (124.7)	12 (5.4)	10 (4.5)	12 (5.4)	74 (33.6)	144 (65.3)	53 (24.0)	Consult Factory	N/A
IP	110 (49.9)	12 (5.4)	10 (4.5)	12 (5.4)	32 (14.5)	134 (60.8)	25 (11.3)	Consult Factory	17 (7.7)
IC	110 (49.9)	12 (5.4)	10 (4.5)	12 (5.4)	32 (14.5)	134 (60.8)	25 (11.3)	Consult Factory	17 (7.7)
AF	275 (124.7)	12 (5.4)	10 (4.5)	12 (5.4)	74 (33.6)	144 (65.3)	53 (24.0)	Consult Factory	N/A

WARRANTY

Total Control Systems 700 rotary meters and accessory components sold to the original purchaser for a period of TWELVE (12) months from installation or EIGHTEEN (18) months from the date of shipment, to be free, under normal use and service, from defects in material and workmanship. If a warranty dispute occurs the DISTRIBUTOR may be required to provide proof of date of sale. Defects occurring within the stated warranty period, will be repaired or replaced, at TCS's option; provided that part or parts are returned to TCS transportation changes prepaid, and TCS's examination discloses the parts or workmanship to have been defective upon delivery to the purchaser. All repaired or warranted meters will be shipped Ex-works Fort Wayne, Indiana. Total Control Systems shall not be liable for consequential damages, whether or not arising out of warranty, negligence or otherwise.

NOTE: The above warranty applies only to Total Control Systems, Fort Wayne, Indiana manufactured products. Private label and OEM engineered products are specifically excluded from the above warranty. Consult factory for non-TCS manufacturer's warranty.



TOTAL CONTROL SYSTEMS
 2515 Charleston Place
 Fort Wayne, Indiana 46808 USA
 (800) 348-4753 • (260) 484-0382
 Fax: (260) 484-9230
 sales@tcsimeters.com • www.tcsimeters.com



"Made in the U.S.A."

SPECIFICATIONS

700-45 Flow Meter

**TOTAL
CONTROL
SYSTEMS**



Total Control Systems rotary positive displacement flow meters offer reliable and precise measurement solutions for preset delivery, flow rate control, blending and custody transfer of vehicle or wholesale measurement applications.

INDUSTRIES SERVED

- Petroleum Products
- Alternative Fuels
- Aviation Fuels
- Agricultural Chemicals
- Petrochemicals
- Textiles
- Foods and Beverages
- Paints and Coatings
- Pharmaceuticals
- Printing Inks

DESIGN

The 700-45 flow meter has a simple and efficient meter design consisting of a housing and three rotors that rotate in unison within the measuring chamber. The absence of wear, from no metal-to-metal contact inside the chamber, eliminates any deterioration in accuracy and provides a long service life. The rotors are supported by bearings inserted into two bearing plates, where at the end of each rotor shaft is a timing gear. The timed rotation between each rotor is then transferred through the calibration adjuster to the register, which will then give a consistent and superior measurement of accuracy.



FLOW ILLUSTRATION

PERFORMANCE FEATURES

LOW PRESSURE DROP: will operate on gravity flow or pump pressure. Maximum pressure differential at 600 GPM (2293 LPM) is 4.5 PSI.

SUSTAINED ACCURACY: no metal-to-metal contact inside the measuring chamber means minimal wear and deterioration in accuracy over time, fewer recalibrations and longer service life.

VISCOSITY RANGE: will accurately measure liquids up to 1,500,000 SSU (325,000 CPS)

LINEARITY:
5:1 Turndown - capable of $\pm 0.100\%$ of maximum nominal flow rate
10:1 Turndown - capable of $\pm 0.125\%$ of maximum nominal flow rate
15:1 Turndown - capable of $\pm 0.150\%$ of maximum nominal flow rate

REPEATABILITY: capable of 0.02% over the entire range of flow

Data provided from test conditions where all system variables were constant. The results are based on the 700 series flow meter and Veeder Root mechanical registration, using 32 SSU testing fluid.

REGULATORY: Meets NIST, USA military and other international weights and measures accuracy requirements.

OPERATING SPECIFICATIONS

DESIGN TYPE: Positive Displacement Rotary Abutment

FLOW CAPACITY: 40 GPM to 600 GPM
151 LPM to 2293 LPM

VISCOSITY: Up to 225 SSU at rated capacity.

PRESSURE RATING: 150 PSI
10.5 BAR

TEMPERATURE RATING: -40°F to 160°F
-40°C to 71°C

CONNECTIONS: 4" NPT Standard; Optional BSPT, Slip Weld, ANSI and DIN flanges are available upon request.

METER TYPES

SPA Standard Petroleum (Aviation)

For metering refined petroleum products; such as Regular and Unleaded Gasoline, Diesel, Bio-Diesel, Aviation Gasoline, Jet Fuel, Naptha, Kerosene, etc.

SPD Standard Petroleum (Ductile Iron)

For metering refined petroleum products; such as Ethanol, Methanol, Regular and Unleaded Gasoline, Diesel, Bio-Diesel, Natural Gasoline, Vegetable Oils, Kerosene, etc.

MATERIALS OF CONSTRUCTION

Meter Type	Housing	Rotors	Bearing Plates	Bearing Sleeves	Journals	Timing Gears	Internal Hardware	Seals
SPA	Anodized Aluminum	Anodized Aluminum	Ni-Resist	Carbon Graphite	Hardchrome Stainless Steel	Stainless Steel	Stainless Steel	Viton®
SPD	Ductile Iron	Stainless Steel	Ni-Resist	Carbon Graphite	Hardchrome Stainless Steel	Stainless Steel	Stainless Steel	Teflon® & Simriz®

Viton is a registered trademark of E.I. Dupont de Nemours & Co.

Teflon is a registered trademark of Dupont Dow Elastomers

Simriz is a registered trademark of Freudenberg-NOK

REGISTRATION OPTIONS

COUNTER REGISTER

Liquid measurement volume indication, using a 5 digit large numeral reset display and an 8 digit non-reset totalizer. Electronic or mechanical meter counter register is available. U.S. or Imperial Gallons, Liters, Dekaliter, Barrels, pounds, etc.

COUNTER PRESET

Select predetermined volume for precise batch control, utilizing preset control valve. Mechanical or electronic preset counters or batch controllers are available.

TICKET PRINTER

Provides an imprinted ticket record of each delivery transaction. Accumulative or Zero-Start, Face down or Face Up mechanical ticket printers available. Electronic slip or roll printers available for use with various electronic registration.

ELECTRONIC METER REGISTER

Digital liquid measurement volume indication that offers multiple functions to enhance the flow meter's accuracy and accountability. Most electronic registration are available with rate of flow indication, pulse output, valve control, RS232 and RS485 communication, currency and temperature compensation.

PULSE TRANSMITTER

The electronic pulse signal output converts the register counter volume per unit value into a electrical pulse stream. The electronic pulse stream can be transmitted to other electronic controllers for rate of flow, volume indication, additive injection or data acquisition.

TEMPERATURE COMPENSATION

Automatically corrects changes in volume caused by liquid temperature variations, during metered delivery. Normally corrects net volume or mass to 60°F (15°C) based on the product's coefficient of expansion, API or specific gravity.

MICROSWITCH

Mechanical signal from the Veeder Root preset counter converted into an electrical or pneumatic signal to provide control of remotely located valve, pump, and other system related equipment.

COUNTER EXTENSION

Raises the elevation of the counter registration for easy visibility or to protect from high temperatures. Counter Extension is required for temperatures more than 180°C (82°C).

RATE OF FLOW INDICATOR

Mechanical or digital indicator displays the volume at which the liquid is flowing through the flow meter.

SWIVEL

Allows mechanical registration to be rotated 360°. Designed for the Veeder Root counter register and ticket printer only.

METER ACCESSORIES

AIR ELIMINATOR

A float and reed valve operated design senses and removes free air or vapor before it can enter the flow meter. Required for custody transfer applications to ensure the most precise measurement.



MECHANICAL PRESET VALVE

A normally closed, hydraulically balanced piston control valve allows for auto-batch preset deliveries. The right angle, two-stage control valve is mechanically linked to Veeder Root Preset Counter.



STRAINER

A 90° strainer provides protection from debris entering into the flow meter. Must be mounted in vertical position when assembled with air eliminator. Stainless steel screens are available in 40, 80, 100 & 200 mesh, and 0.050 perforation.



ELECTRONIC PRESET VALVE

A normally closed, two-stage diaphragm preset valve for use with electronic relay control. The solenoid valves are available in 12 or 24 VDC, or 110 VAC coils.



BULK AIR ELIMINATOR

A bulk air eliminator assembly is designed for use in applications where a high volume of free air may enter the measurement storage system. Available with single or dual SP, AF or SS air eliminators assembled to stainless steel vessel.



WAFER CHECK VALVE

In-line check valve is mounted between the strainer and meter assembly to help increase air eliminator efficiency by creating additional back pressure.



ASSEMBLY COMBINATIONS

GROUP COMBINATIONS

- 2 **Meter & Register**
- 3 Meter, Register & Ticket Printer
- 4 **Meter, Register, Air Eliminator & Strainer**
- 4R **Meter, Register, Air Eliminator & High Volume Strainer**
- 5 Meter, Register & Strainer
- 6 Meter, Register, Ticket Printer, Air Eliminator & Strainer
- 6R Meter, Register, Ticket Printer, Air Eliminator & High Volume Strainer
- 7 Meter, Register, Printer, & Strainer
- 8 **Meter, Register, Preset & Valve**
- 9 Meter, Register, Ticket Printer, Preset & Valve
- 10 **Meter, Register, Preset, Valve, Air Eliminator & Strainer**
- 10R **Meter, Register, Preset, Valve, Air Eliminator & High Volume Strainer**
- 11 Meter, Register, Ticket Printer, Preset, Valve, Air Eliminator & Strainer
- 11R Meter, Register, Ticket Printer, Preset, Valve, Air Eliminator & High Volume Strainer
- 12 Meter, Register, Preset, Valve & Strainer
- 13 Meter, Register, Ticket Printer, Preset, Valve & Strainer

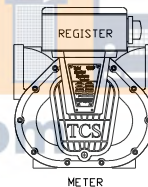

GROUP 2

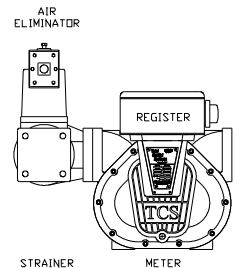

GROUP 4

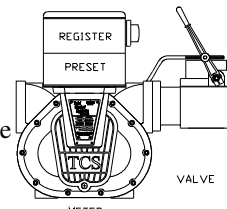

GROUP 8

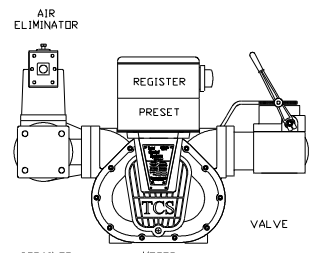

GROUP 10

METER ORIENTATION

- A Meter Assembly with Veeder Root Registration
- B Meter assembly less Veeder Root Registration
- C Meter Assembly for use with Electronic Registration (less calibration adjuster)
- D Meter Assembly with direct drive pulse transmitter



Meter A
(700-20SP10AT)



Meter B
(700-20SP10RBX)



Meter C
(700-20SP10CXA)



Meter D
(700-30SP2DX)

700-45 DIMENSIONS

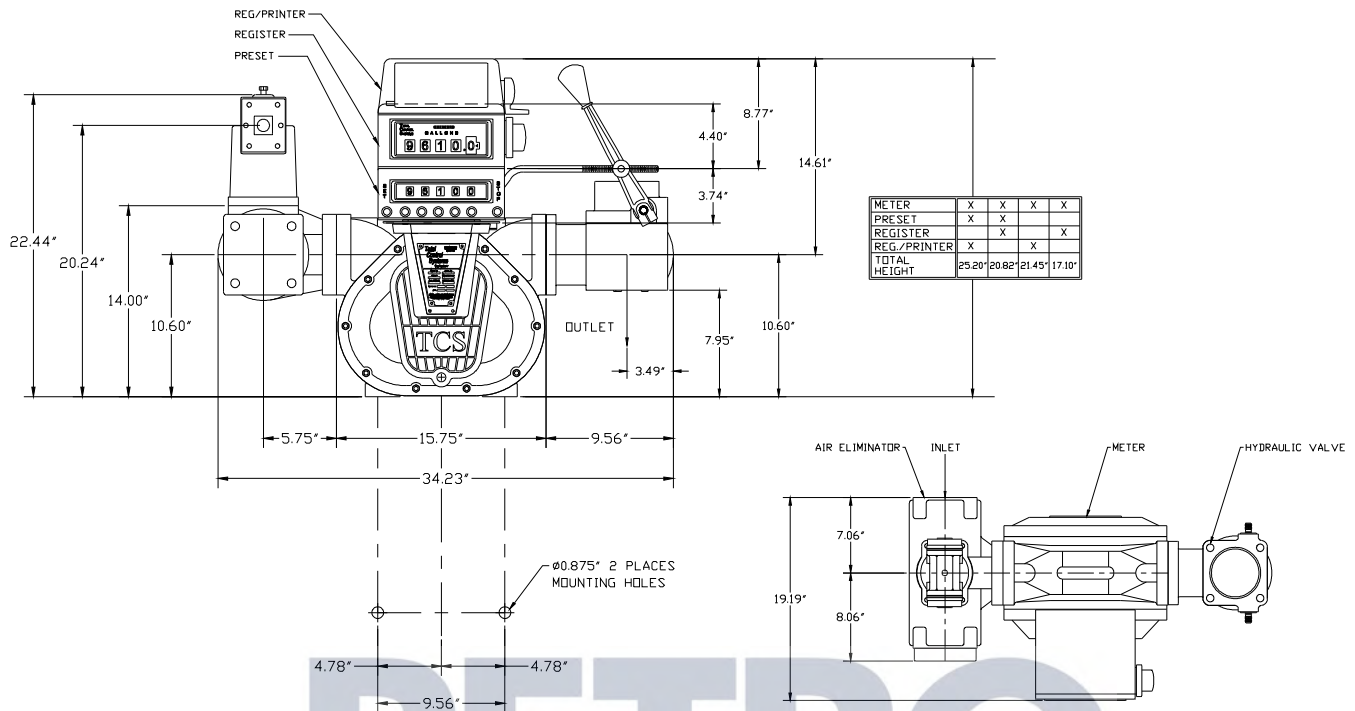

700-45 NET WEIGHTS IN POUNDS (KILOGRAMS)

Meter Type	Flow Meter	Register Counter	Preset Counter	Ticket Printer	Air Eliminator/Strainer	Bulk Air Eliminator	Strainer	Electronic Valve	Mechanical Valve
SPA	110 (49.9)	12 (5.4)	10 (4.5)	12 (5.4)	32 (14.5)	134 (60.8)	25 (11.3)	Consult Factory	17 (7.7)
SPD	275 (124.7)	12 5.4	10 4.5	12 5.4	74 (33.6)	144 (65.3)	53 (24.0)	Consult Factory	N/A

WARRANTY

Total Control Systems 700 rotary meters and accessory components sold to the original purchaser for a period of TWELVE (12) months from installation or EIGHTEEN (18) months from the date of shipment, to be free, under normal use and service, from defects in material and workmanship. If a warranty dispute occurs the DISTRIBUTOR may be required to provide proof of date of sale. Defects occurring within the stated warranty period, will be repaired or replaced, at TCS's option; provided that part or parts are returned to TCS transportation changes prepaid, and TCS's examination discloses the parts or workmanship to have been defective upon delivery to the purchaser. All repaired or warranted meters will be shipped Ex-works Fort Wayne, Indiana. Total Control Systems shall not be liable for consequential damages, whether or not arising out of warranty, negligence or otherwise.

NOTE: The above warranty applies only to Total Control Systems, Fort Wayne, Indiana manufactured products. Private label and OEM engineered products are specifically excluded from the above warranty. Consult factory for non-TCS manufacturer's warranty.



TOTAL CONTROL SYSTEMS
 2515 Charleston Place
 Fort Wayne, Indiana 46808 USA
 (800) 348-4753 • (260) 484-0382
 Fax: (260) 484-9230
 sales@tcsmeters.com • www.tcsmeters.com



"Made in the U.S.A."