

Medium capacity flowmeters

POSITIVE DISPLACEMENT FLOWMETERS

Flowmec medium capacity flowmeters provide precise volumetric flow measurement of clean liquids found in a broad range of industries including automotive, aviation, mining, power, chemical, pharmaceutical, food, paint & petroleum. Applications include the distribution of fuels, fuel oils, lubricants, alcohols, solvents, blending of bio & ethanol fuels, metering of chemicals, grease, adhesives, ink, insecticides & non-conductive liquids either pumped or gravity fed.

FEATURES/BENEFITS

- High accuracy & repeatability, direct reading flowmeter
- No requirement for flow conditioning (straight pipe runs)
- All metal rotors standard
- Measures high & low viscosity liquids
- Quadrature pulse output option & bi-directional flow

METER SELECTION

- Aluminium meters are used for petroleum products including oils and grease, fuels and fuel oils.
- Stainless steel meters are for chemicals, water base liquids or where aluminium is not suited or permitted.
- Blind pulse meters are available with a reed switch & open collector outputs. Quadrature pulse outputs are optional.

INTEGRAL INSTRUMENTS

Flowmec meter options include integral LCD totalisers, flow rate totalisers & batch controllers. These instruments provide monitoring & control outputs including 4~20mA, scaled pulse, alarms & batch. Robust mechanical registers complete range :

- BT 5 digit reset, 8 digit cumulative totaliser.
 - RT 6 digit reset, cumulative totaliser & flow rate.
 - EB 6 digit 2 stage batcher & cumulative totaliser.
 - M* = Mechanical registers (see model numbering)
- (Instruments also available for remote mounting and with I.S. approvals)

GENERAL SPECIFICATION

Flow rates : 1 ~ 450 litres / min. (0.26~ 120 USgal/min) *

Sizes : 15~50mm (1/2~2"NB)

Materials : Aluminium or 316 Stainless steel

* see also small & large capacity data sheets for other size meters



Pulse meter



with LCD register



with 3 or 4 digit mechanical register

SPECIFICATIONS

Model prefix :	OM015	OM025	OM040	OM050
Nominal size (inches)	15mm (1/2")	25mm (1")	40mm (1 1/2")	50mm (2")
* Flow range (litres / min)	1 ~ 40	10 ~ 150	15 ~ 250	30 ~ 450
* Flow range (USGM)	0.26 ~ 10.6	2.6 ~ 40	4 ~ 66	8 ~ 120
Accuracy @ 3cp	± 0.5% of reading (± 0.2% with optional RT12)			
Repeatability	typically ± 0.03%			
Temperature range	-20°C ~ +120°C (-4°F ~ +250°F)			
Maximum pressure (threaded meters)	bar (PSI)			
Aluminium	68 (1000)	68 (1000)	30 (440)	20 (300)
316L stainless	100 (1500)	100 (1500)	100 (1500)	38 (560)
high pressure stainless	refer factory for options			
Protection class	IP66/67 (NEMA4X), optional Exd IIB T6 or I.S.			
Recommended filtering	150 microns (100 mesh) minimum			
Electrical - for pulse meters (see also optional outputs)				
Output pulse resolution	pulses / litre (pulses / US gallon) - nominal			
Reed switch	83 (314)	27 (102)	13 (50)	6.5 (25)
Hall effect	166 (628)	107 (405)	52.6 (200)	26 (99)
Quadrature Hall option	166 (628)	53.5 (203)	26.3 (100)	13 (50)
Reed switch output	30Vdc x 200mA max. (max. temp. shock 10°C (50°F) / min)			
Hall effect output (NPN)	3 wire open collector, 5~24Vdc max., 20mA max			
Optional functions				
Display	flowrate, total (accumulative & resettable)			
Preset batching	1 & 2 stage high speed batch control			
IP65 3 digit reset mechanical totaliser	999.9 ltr/gal		9999 litres or gallons	
IP65 4 digit reset mechanical totaliser	9999.9 ltr/gal		99999 litres or gallons	
Mechanical Accum. totaliser capacities	M1 & M2 (6 digit), M3 & M4 (8 digit)			
Optional outputs				
Flow	4 ~ 20mA, high & low flow rate alarms			
Pulse	scaled pulse (programmable), pulse amplifier			

* Maximum flow on fuels may be maintained for intermittent periods of refuelling.
* Maximum flow is to be reduced as viscosity increases, max. pressure drop 100Kpa (15psi)

DIMENSIONS

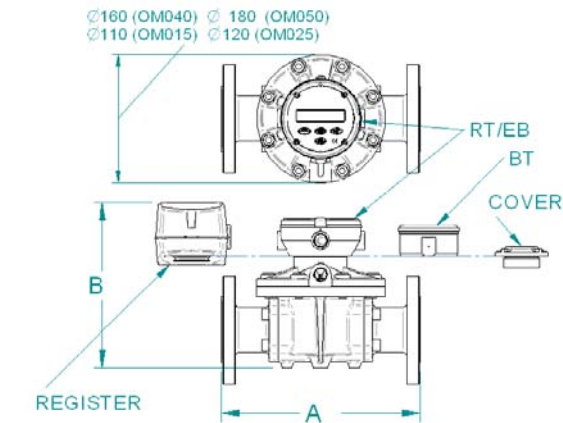

ALL DIMENSIONS IN MILLIMETERS

Modular Fitting	A				Configuration	B			
	OM015	OM025	OM040	OM050		OM015	OM025	OM040	OM050
A.N.S.I. 150	243	272	278		RT/EB REGISTER	144	155	201	208
DIN 16		243	272	278	BT REGISTER	135	146	192	199
JIS 10K		243	272	278	COVER	106	117	163	170
B.S.P.	112	177	208	212	MECH REGISTER	167	178	224	231
N.P.T.	112	177	208	212					

ACCURACY & PRESSURE DROP

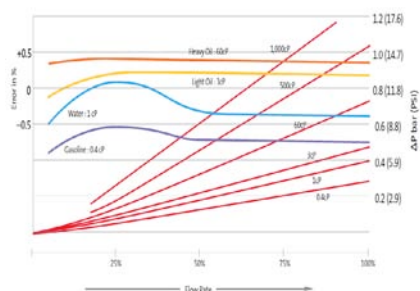

MODEL CODING

OM015	15mm (1/2")
OM025	25mm (1")
OM040	40mm (1 1/2")
OM050	50mm (2")



Body material

A	Aluminum
S	316 Stainless Steel
H	High pressure stainless

Rotor material

4	Aluminum
5	Stainless Steel
9	Application specific

Bearing type

1	Ceramic (SS rotors)
4	Hardened steel roller bearings (Alum. rotors)

O-ring material

1	Viton (standard) -15~+200°C [-5~+400°F]
2	Ethylene Propylene Rubber -150°C (300°F) max.
3	Teflon encapsulated viton -150°C (300°F) max.
4	Buna-N (Nitrile) -65~+100°C (-53~+212°F)

Temperature limits

2	120°C (250°F) ¹
5	120°C (250°F) ²

Process connections

1	BSP female threaded
2	NPT female threaded
4	ANSI-150 RF flanges
5	ANSI-300 RF flanges
6	PN16 DIN flanges
9	Customer nominated

Cable entries

0	3~6mm cable gland (B2/B3 options)	Code O with mechanical register options
1	M20 x 1.5mm	
2	1/2" NPT	

Model No. Example

OM025 A 4 4 1 - 5 1 1 R2

Integral options

2 NPN open collector phased outputs	QP	Quadrature pulse output
IECEX & ATEX approved	E1	Explosion proof - Exd
IECEX & ATEX approved	Q1	Exd with Quadrature pulse
accum. & reset totals, pulse output	B2	BT11 dual totaliser
IECEX & ATEX approved	B3	Intrinsically safe BT11 (I.S.)
Flow rate, totals & all outputs	R2	RT12 Flow Rate Totaliser
IECEX & ATEX approved	R3	Intrinsically safe RT12 (I.S.)
dc 2 stage batch controller	E0	EB10 batch controller
M* = M1 litres, M2 gallons	M*	3 digit mechanical reset totaliser
M* = M3 litres, M4 gallons	M*	4 digit mechanical reset totaliser
Consult factory	SB	Specific build requirement

¹ 120°C (250°F) rating of the pulse meter, 80°C (180°F) rating with BT, RT & EB options.
See temperature code 5 for higher temperature with BT, RT, & EB
² Cooling fin is fitted with integral instruments for operation between 80~120°C (180~250°F)

Recommended strainer (air eliminators available)

ST015S1	15mm (1/2") - 316SS
ST025S1	25mm (1") - 316SS
ST040S1	40mm (1 1/2") - 316SS
ST050S1	50mm (2") - 316SS

