

# EBSRAY PUMPS

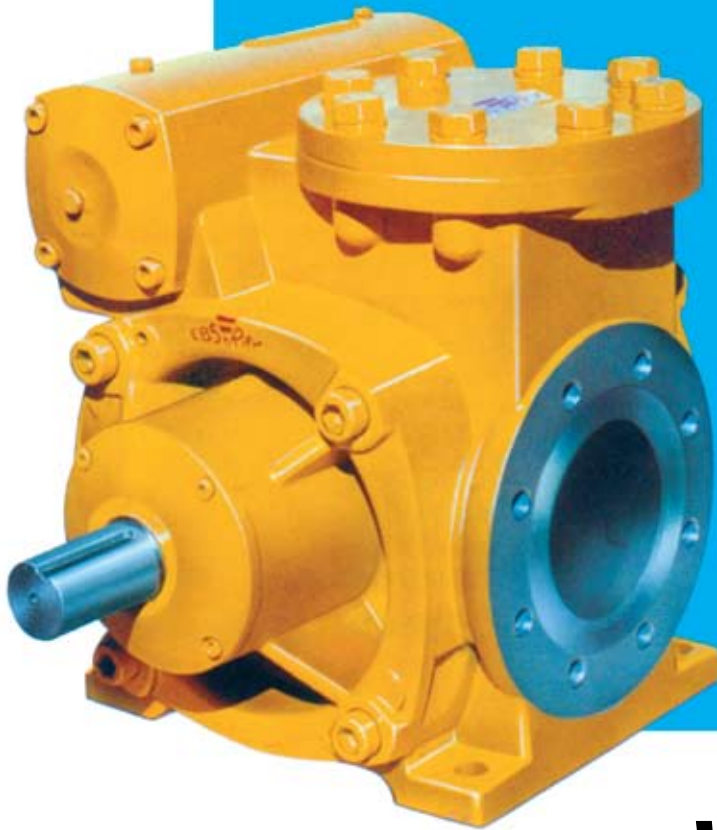

## *V Series Model V40*



# V Series Model V40



High Capacity rail tank car unloading



Robust Portable units



Electric Motor driven units



Oil Terminal load in/load out

Designed and precision built for efficient transfer of a wide variety of lubricating and non-lubricating liquids and capable of handling a broad range of viscosities.

## SPECIFICATIONS

Flows.....to 2000 L/min (33.3 L/sec)  
Differential pressure to.....850 kPa  
Viscosity range.....up to 10,000 cSt  
Temperatures to.....100°C

## FEATURES

- Quiet operation.
- High overall efficiency.
- Low maintenance - long life.
- Internal wearing parts replaceable without moving pump from piping.
- Vanes positively actuated and self compensating for wear.
- Self Priming.
- Excellent vapour handling.
- Integral adjustable bypass valve.
- Drive options available to suit many applications.

## TYPICAL SERVICES

Transport Tanker Services  
Petroleum and Fuel Oil Industries  
Liquified Gas Industries  
Chemical and Pharmaceutical Industries  
Lubricating oil transfer and blending  
Paint Industry  
Public Utilities  
Power Stations  
Edible Oil Industry

## COMMON LIQUID APPLICATIONS

Fuel Oils	Transformer Oils
Lube Oils	Solvents
Distillate	Chemicals
Petrol	Vegetable Oils
Kerosene	Aviation Fuels
L.P.G.	Oil Additives

## ASSURED PERFORMANCE

All EBSRAY V Series Model V40 pumps are run tested prior to dispatch in order to ensure performance in accordance with pump specifications.

The high standards of engineering design, manufacturing and testing combine to make out pumps capable of long life and trouble-free service.

## SPECIAL CONSTRUCTIONS

Contact EBSRAY or your local representative for advice on alternate arrangements to meet applications not outlined in this catalogue.

***Ebsray Pumps are designed and manufactured in Australia.***

# Features

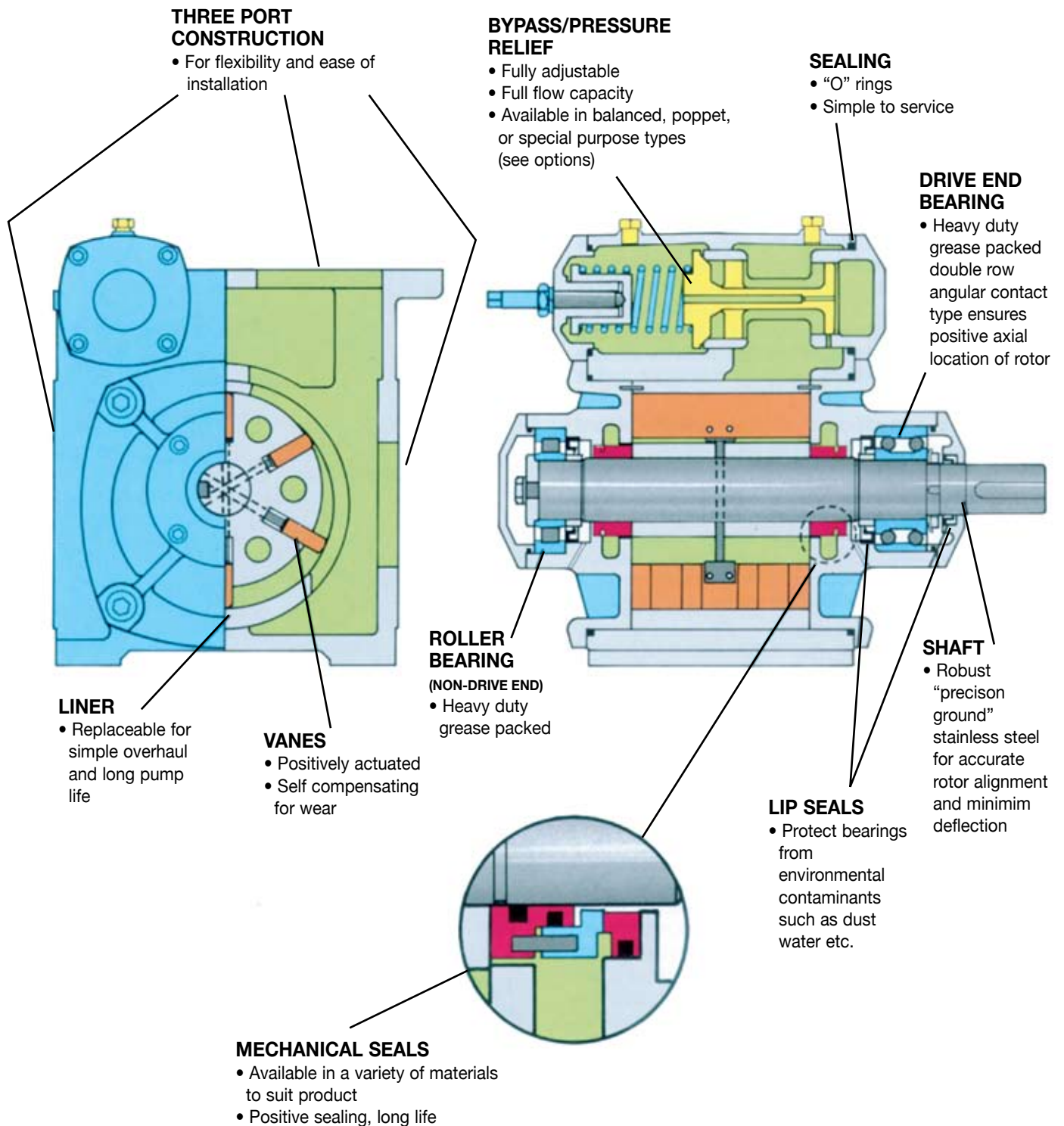

## VAPOUR PRESSURE LIMITING VALVE (VPL)

Due to the excellent vapour/air scavenging ability of the V40, it is possible to pass large volumes of air and/or vapour onto the discharge side of the pump during priming or suction line stripping. While this is normally a major advantage of this type of pump, it can be a problem when the pump is used in conjunction with sensitive meters or coalescers due to the limited ability of the vapour eliminators to handle high volumes of air/vapour. This may cause difficulty for meters, build up of static, or incorrect functioning of the coalescer. To aid the correct operation of these air eliminators EBSRAY have developed a special valve to limit the differential pressure that the pump can develop when pumping mainly air and/or vapour.

This valve is a modification of the standard integral bypass/pressure relief valve and acts as an “excess flow” type valve. When only air/vapour is being pumped, the dynamic pressures of the fluid flow are insufficient to drive the ball onto its seat against spring pressure. Once full liquid flow is achieved, the ball valve is forced onto its seat and the valve acts as normal integral full flow bypass/pressure relief valve. This gives the pump a similar priming characteristic to a self priming centrifugal pump.

**NOTE** this feature should only be used when positive static suction head conditions exist.

## PRESSURE AND FLOW MODULATING VALVE (PFM)

Many systems require that a positive displacement pump be used for a wide range of output flow-rates eg the duty cycle may vary from bulk filling and recirculations to small batch and drum filling. While speed control is a possibility it is often an expensive option. Variable displacement pumps are unnecessarily complicated and expensive.

When applications do require flow variation at a fixed pressure, or simple pressure adjustment without pump speed regulation, EBSRAY's integral PFM valve has distinct advantages. The PFM valve is controlled by an external air, gas, or hydraulic circuit. System modulation is predictable, pressure variation linear and response time between a rise in system pressure and valve compensation is very short. The compact integral design reduces the space requirements and eliminates costly speed control pressure transducers. The ability to control the flow/pressure from remote locations using simple regulators (manually, electronically etc.) increases the valve's versatility.

Refer EBSRAY PFM System brochure.

### VAPOUR PATH

- Low resistance (when in VPL mode)

### BALL

- Non-metallic for quiet actuation and positive sealing

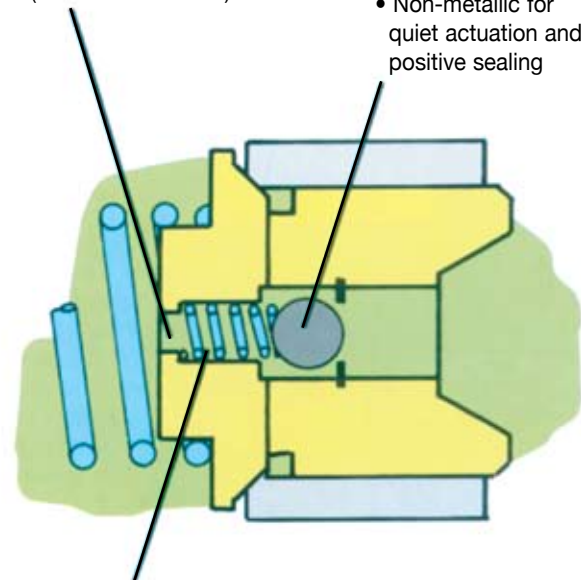

### SPRING

- Stainless Steel

PFM Valve fitted to V40 Pump



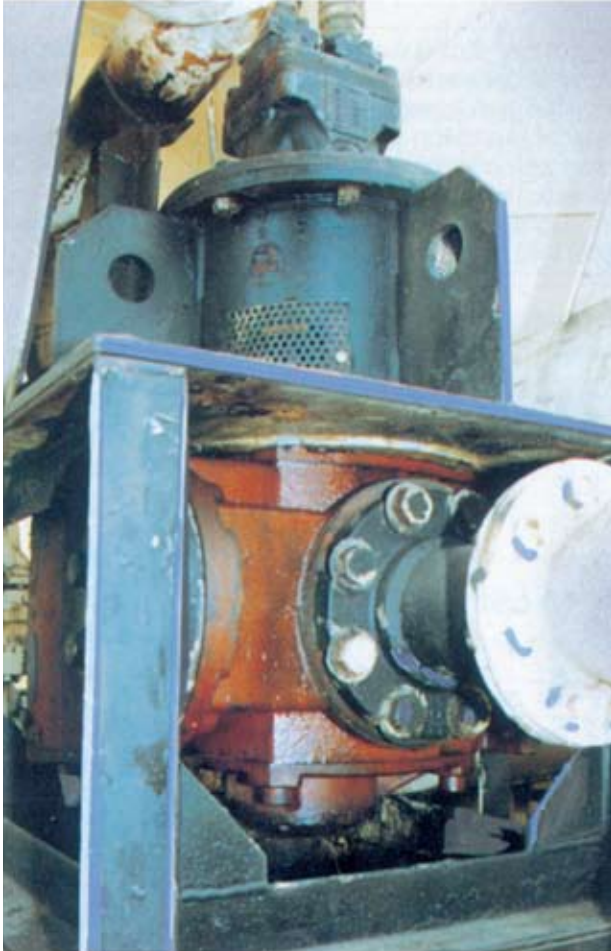

## VARIETY OF PORTING/MOUNTING OPTIONS

Multi porting combined with very compact casing design allows installation of the pump in confined spaces or areas with limited access. The V40 has been designed with 3 ports to provide either two suction or two discharge options allowing 180° or 90° configuration.

*The unit shown opposite is a vertically mounted, hydraulically driven unit used for loading and unloading a lube oil additive barge. Hydraulic drive allows the pump to be lowered into deep holds on tankers thus reducing suction losses and enabling high pump out rates. Variable pump speed control is incorporated for final stripping operations.*

## MAIN MATERIALS OF CONSTRUCTION

(Standard - unless otherwise specified)

BODY (pressure casings)...	DUCTILE IRON - ASTM A395
LINER.....	CAST IRON
SHAFT.....	STAINLESS STEEL
ROTOR.....	CAST IRON
VANES.....	SYNTHETIC
MECHANICAL SEALS.....	CARBON/NITRESIST
ELASTOMERS.....	VITON (SEAL) NITRILE (CASINGS)

Other materials are available to suit almost any application. Please contact your EBSRAY representative for more information.

LPG installation



## LPG APPLICATIONS

(refer separate performance data)

All pumps manufactured by EBSRAY for use in LPG transfer applications are designed and built to comply with the requirements of Australian Standard AS-1596. Specific material selection for pressure retaining castings, vanes, seal faces etc. ensures maximum safety, component integrity, quality assurance and long service life. EBSRAY also manufacture a range of "In-Line" bypass/pressure relief valves for use in LPG services.

# Performance Data

## EFFICIENCY GRAPH

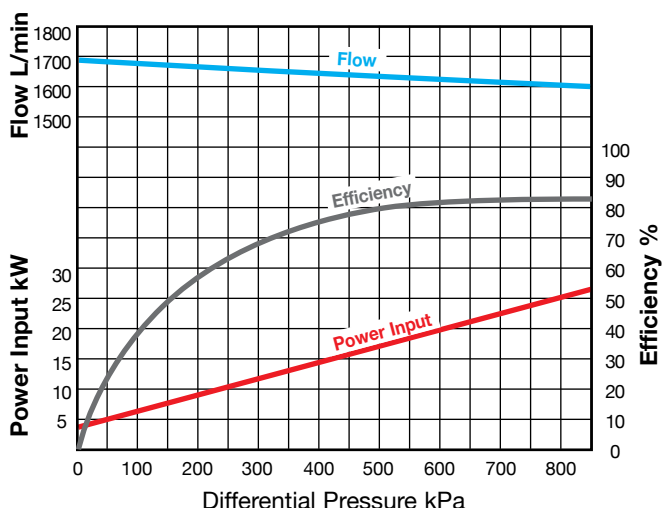

## HIGH PUMP EFFICIENCY

Being of the "sliding vane principle", all EBSRAY V Series pumps will operate efficiently over a wide range of pressures, viscosities and speeds.

A typical illustration is shown in the diagram opposite. Under ideal conditions it is possible to attain higher efficiency than indicated here.

The diagram shows a typical performance of V Series Model V40.

**Kinematic Viscosity:** 10cSt  
**Speed:** 600 RPM

### 1cSt

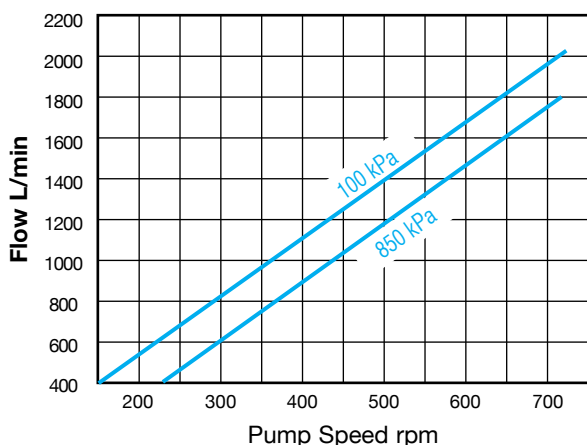
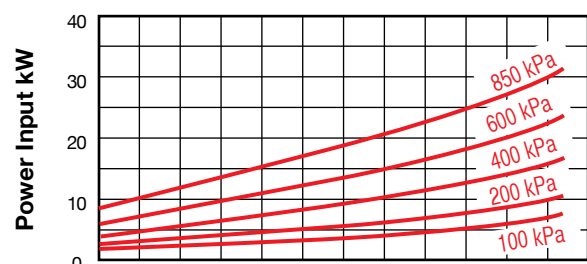

### 10cSt

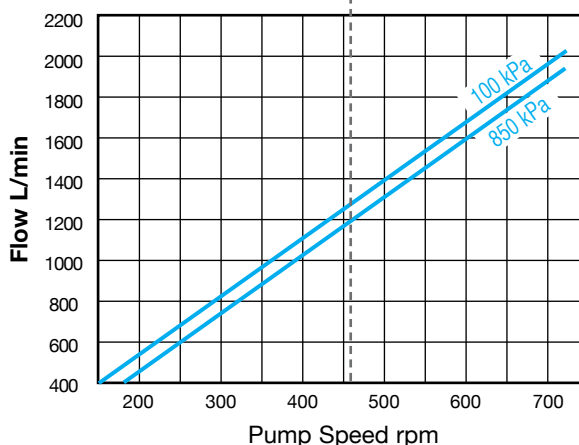
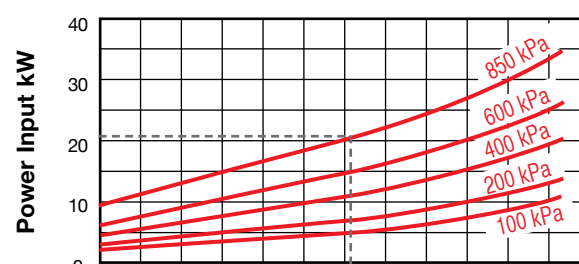

## Notes

1. POWER INPUT (kW) specified is measured under controlled testing condition of speed, kinematic viscosity and differential pressure. Any variation in these parameters will alter POWER INPUT. Therefore adequate allowance must be made over and above POWER INPUTS indicated for losses due to drives, couplings, gearboxes etc, as well as margins for variables such as viscosity change or bypass valve overpressure when determining power required.

2. SPEED (rev/min) specified is the safe recommended speed which the pump can attain when delivering full flow at the stated viscosity. Refer performance graphs.

3. Pump performance may be affected by NPSH available. This should be verified for each application.

4. For parameters outside those printed above contact EBSRAY or representative for details.

**100 cSt**

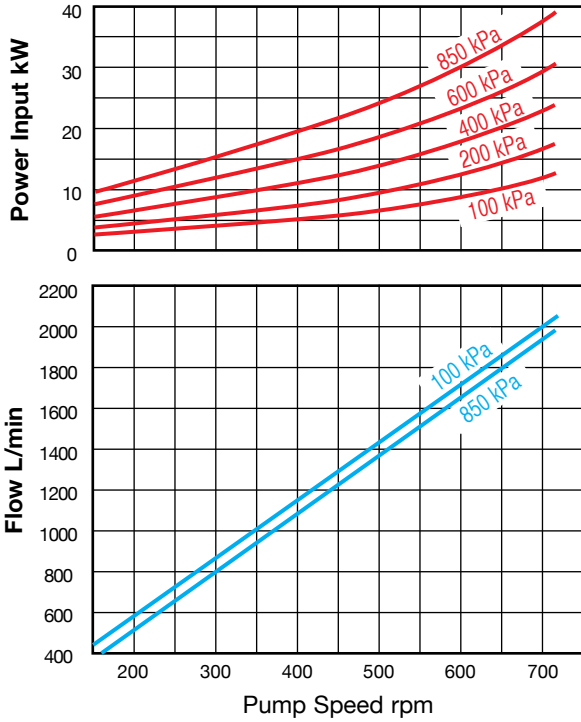

**500 cSt**

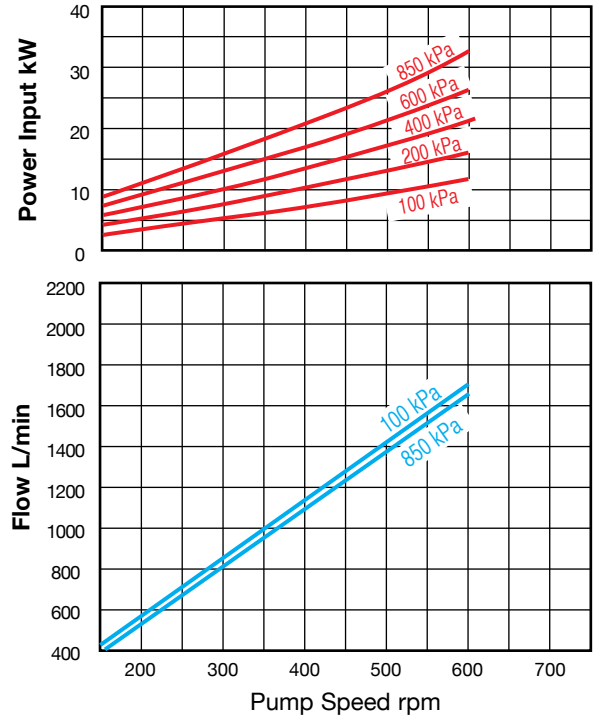

**1500 cSt**

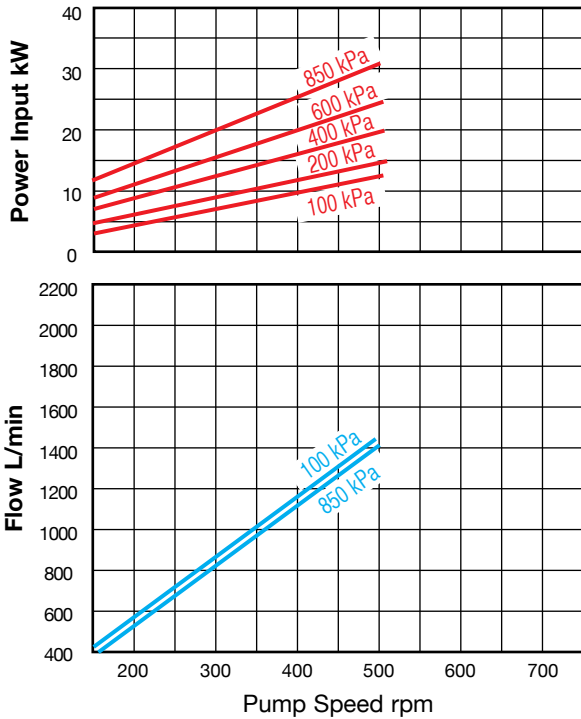

**3000 cSt**

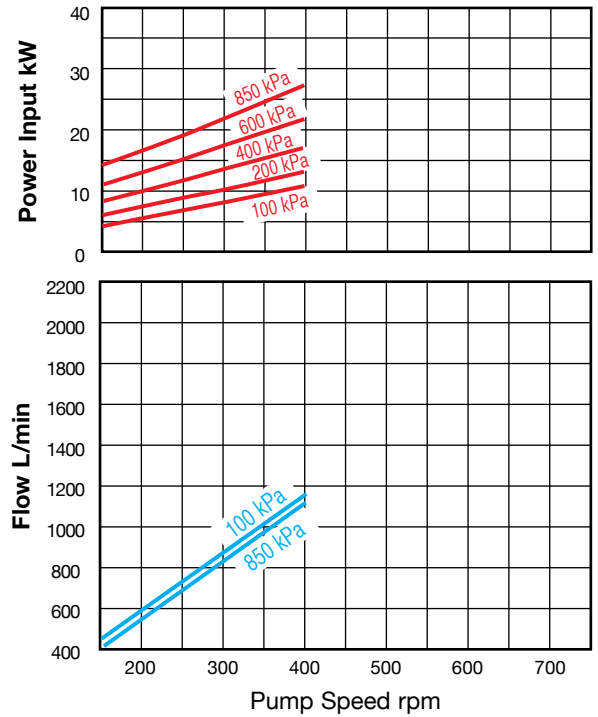

**Using these Graphs**

**Example**

Flow 1200 L/min

Differential Pressure 850kPa

Viscosity 10 cSt

Select the 10 cSt graph. Trace 1200 L/min horizontally

to its point of intersection with the 850kPa FLOW curve. Read required pump speed directly below, i.e. 460 rpm.

Transfer vertically upwards to point of intersection with 850kPa POWER INPUT curve. Read off required power input, i.e. 21 kW. Motor selection 25 or 30 kW at indicated speed.

# Dimensions

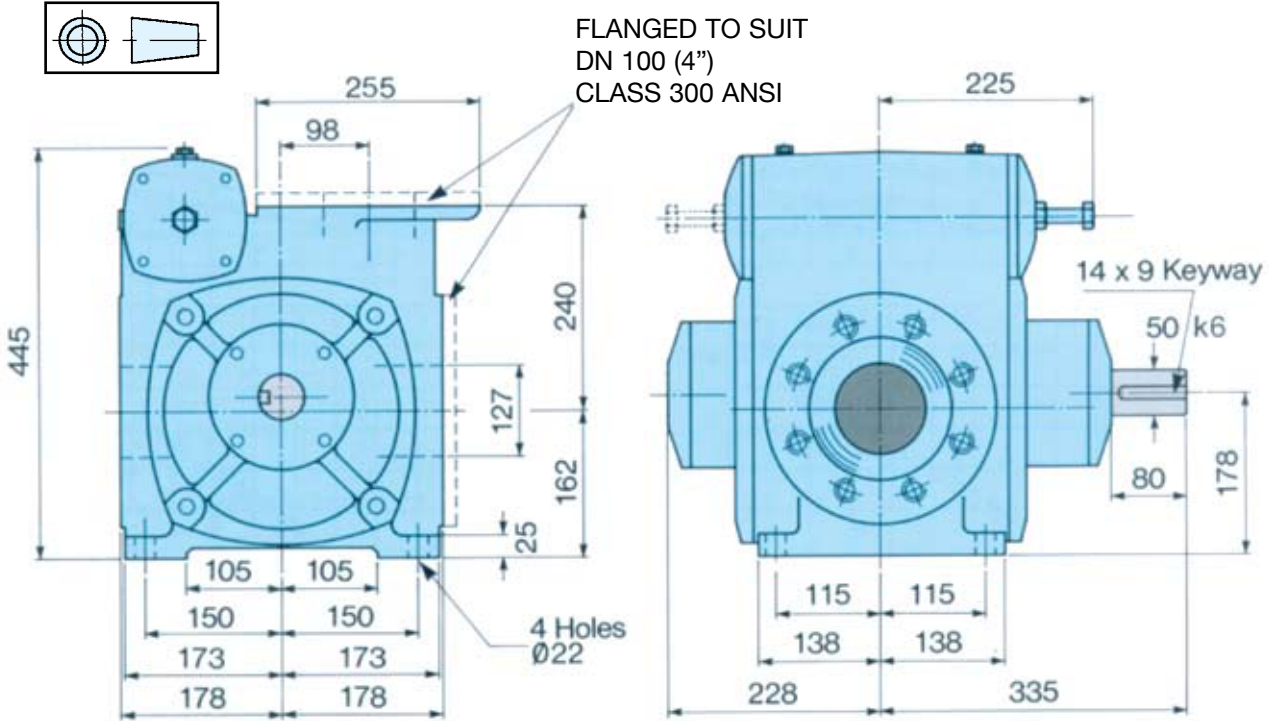

Bare Shaft Pump  
Weight: 202kg (Standard Construction)

## PORTING CONFIGURATION

These designations apply when the pump is viewed "from" the drive end. Clockwise rotation pumps have the Bypass Valve Adjusting Screw "opposite" the drive end. Anticlockwise rotation pumps have the Bypass Valve Adjusting Screw "at" the drive end.

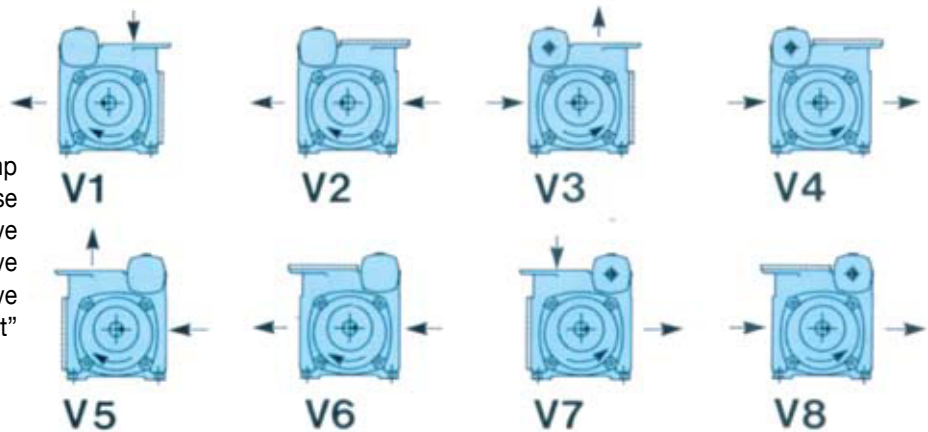

**NOTE:**

All specifications and illustrations are typical only and subject to revision without notice. Certified data available on request.