

CUBE MC



CONSUMER PUMPS

**USE AND
MAINTENANCE
MANUAL**

ENGLISH

DECLARATION OF CONFORMITY

The undersigned, representing the following manufacturer

PIUSI S.p.A.
46029 SUZZARA (MANTOVA) ITALY

hereby CERTIFIES that the equipment described below:

Description: **DIESEL FUEL DISPENSER**
Model: **CUBE MC**

Complies with the following directives:

- **89/336 EEC** (Electromagnetic Compatibility Directive EMC) and subsequent amendments
- **73/23 EEC** (Low-Voltage Directive) and subsequent amendments

This is in conformity with the following International Standards (and their subsequent amendments):

- EN 292-1** Safety of Machinery - Basic Concepts, General Principles for Design - Terminology, Basic Methodology.
- EN 292-2** Safety of Machinery - Basic Concepts, General Principles for Design - Specifications and Technical Principles.
- EN 294** Safety of Machinery - Safe Distances to Prevent the Operator's Upper Limbs from Reaching Dangerous Areas.
- EN 61000-6-1** Electromagnetic compatibility - Generic standards - Immunity for residential, commercial and light-industrial environments.
- EN 61000-6-3** Electro-Magnetic Compatibility - Generic Emission Standards - Residential, Commercial and Light Industrial Environments.
- EN 60204-1** Safety of Machinery - Electric Equipment of Machines - General Rules.
- EN 60335-1** Household and similar appliances - Safety - General requirements.
- EN 60335-2-41/A1** Household and similar appliances - Safety - Particular requirements for pumps.
- EN 60335-2-75** Household and similar appliances - Safety - Particular requirements for commercial dispensing appliances and vending machines (electrical or gas powered).

And is in conformity with the following Italian National Decrees:

MD 31.07.1934 -Heading 1 No. XVII

Approval of the applicable Safety Rules for the storing, use and transport of mineral oils.

Last two figures of the year of CE marking: 04

Suzzara, 01.01.04

OTTO VARINI, Chairman



B FIRST AID RULES



Persons who have ingested toxic liquids: whenever fuel has been swallowed, do not induce vomiting, but have the injured person drink large quantities of milk or water.



Persons who have suffered electric shock: disconnect the power source, or use a dry insulator to protect yourself while you move the injured person away from any electrical conductor. Avoid touching the injured person with your bare hands until he is far away from any conductor. Immediately call for help from qualified and trained personnel.

IN ALL CASES, SEEK MEDICAL ATTENTION IMMEDIATELY

C GENERAL INFORMATION

CUBE MC dispensers are appliances designed for the private distribution of diesel fuel for motor transport. All the models of the series have the same sturdy metal structure and self-priming type pumps. Reliability of the pumping units, precise measuring of the dispensed product and Control System efficiency are the strong points of CUBE MC. This manual refers to CUBE MC models only.

D SAFETY INSTRUCTIONS

All the CUBE MC models have been designed and built according to applicable EC directives relating to essential safety and health requirements.

Page 28 of this manual shows a copy of the manufacturer's DECLARATION OF CONFORMITY.

D1 SAFETY RULES



Protective gloves. Prolonged contact with hydrocarbons can cause skin irritation: when dispensing fuel always use PVC gloves conforming to the standard EN 388 cat.2.



Permitted uses. The unit must always be used for the purpose intended. Follow the instructions listed in the chapter Instructions for Use.



Overheating. To prevent overheating, make sure that the pump of the dispenser stops whenever fuel has not been dispensed for more than 2 minutes.



Smoking prohibited. When operating the dispenser and in particular during refuelling, do not smoke and do not use open flame.



Electrical precautions. There are dangerously high voltages inside the unit. Only qualified and authorized technical personnel are allowed to open the dispenser.



Service. Service of the dispenser must be performed by qualified personnel.

D2 TRANSPORT, HANDLING AND UNPACKING

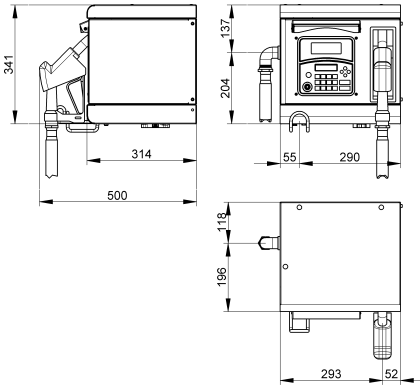

CUBE MC is shipped inside stackable cardboard packaging.

DIMENSIONS OF PACKAGING:

h=480 mm /
L=380 mm /
D=380 mm

TOTAL WEIGHT:

CUBE 70 MC = 26.5 kg

WEIGHT OF

PACKAGING: 1.8 kg

When the machine is not used, whether it is packed or unpacked, it must be stored in a place protected from the weather (rain, damp, sun, etc.) and from dust. To remove the cardboard packaging, use a pair of scissors or cutters, being careful not to damage the appliance. Fully open the packaging and take out the CUBE MC so that it can be taken to the place of final installation. Once the packaging has been removed, the station must always be kept in vertical position. Packaging parts (cardboard, wood, cellophane, etc...) must be placed in specific containers and not left lying around or within reach of children, as these represent a potential risk hazard. They must be disposed of according to the regulations applicable in the country of use.

Check the integrity of the machine by making sure the shipped parts are not damaged in any way that could affect safety and operation. In case of any doubts, do not start the appliance but contact the manufacturer's after-sales service.

After unpacking, proceed to assemble the CUBE MC, as shown below:

- Fit the hose support hook (PHOTO No. 1)
- Fit the equaliser operating lever (PHOTO No. 2)
- Apply thread sealer at the points shown in the photo, before proceeding with final assembly. (PHOTO No. 3)

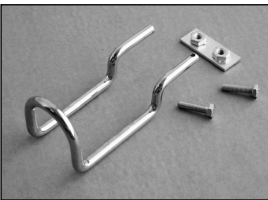

PHOTO No. 1

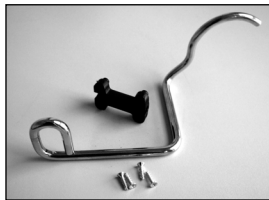
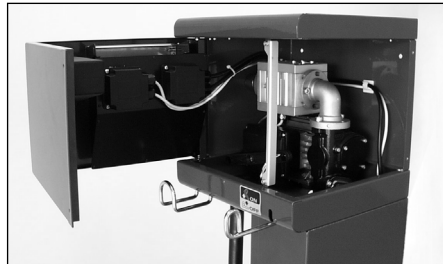
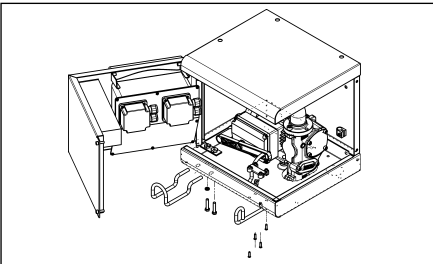

PHOTO No. 2



PHOTO No. 3



D3 DISPOSAL

In the event that the dispenser is to be demolished, the parts of which it is composed must be sent to companies that specialize in the disposal and recycling of industrial refuse and, in particular:

PACKING MATERIAL DISPOSAL:

The packing material consists of biodegradable cardboard that can be delivered to companies that normally recover cellulose.

METAL PARTS DISPOSAL:

The metal parts, both painted and stainless steel are normally recoverable by companies specialized in scrapping metal.

DISPOSAL OF ELECTRONIC BOARDS:

The electronic boards must necessarily be disposed of through companies specialised in the disposal of electronic components.

MISCELLANEOUS PARTS DISPOSAL:

Additional parts making up the dispenser, such as tubes, rubber gaskets, plastic parts and wiring harness, must be delivered to companies specialized in the disposal of industrial refuse.

E

USING AND LOOKING AFTER MANUALS

This manual is common to all CUBE MC models and illustrates the main characteristics of the various models, providing information on:

- electrical and mechanical installation
- first start up operations
- daily use

This manual DOES NOT cover other aspects such as:

- configuration and operation of the Control system

For these aspects, refer to the specific manuals which accompany each station model.

ATTENTION

The list in paragraph F1 indicates the number of the manual where the component is described in detail (pump, meter, control system, etc.)

For the installer's convenience, all supplied manuals are grouped together in an envelope.

This collection of manuals is an integral and essential part of the product and, as provided by EEC directive 89/392, must be given to the persons in charge of using and servicing the machine, to ensure fulfilment of the provisions relating to training/information referred to in EEC directive 89/391.

Carefully read the instructions contained in these manuals, as these are most important for installation safety, operation and maintenance.

The manufacturer disclaims all liability for injury to persons or damage to things, or the machine, in the event of this being used in a way different to that indicated in the instructions.

Look after this manual carefully in a place protected from damp, heat, dust, oils, greases, etc., as it will be useful for future reference and consultation. Do not remove, tear or amend any parts of the manual for any reason. In case of loss or damage, ask the manufacturer for a copy, quoting the manual code.

This manual must always remain with the machine; in the event of the machine being sold, it must be given to the new user.

ATTENTION

The company reserves the right to change CUBE MC features and specifications at any time.

E1 LIST OF SUPPLIED MANUALS

Below is a list of all the manuals, besides this one, to be provided together with the CUBE MC:

- M0042 Panther 72 pump manual
- M0046 K600 meter manual
- M0103 CUBE MC control system manual
- M0105 Cube MC software manual

E2 IDENTIFICATION PLATE

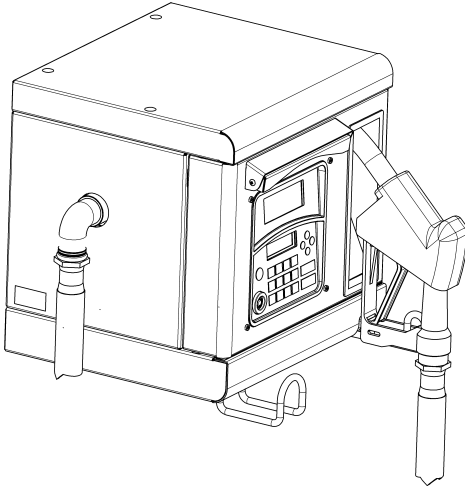

The cube MC stations feature an identification plate showing:

- Model
- Serial number / Year of manufacture
- Technical specifications
- CE mark

	PIUSI	CUBE MC	PRODUCT NAME
		CODE 000593000	PRODUCT CODE
MANUFACTURER	PIUSI S.P.A. SUZZARA (MN) ITALY <small>CERTIFIED COMPANY UNI-EN ISO 9001</small>	230 V 50 Hz 3,3 A 3550 W 2800 rpm IP55	TECHNICAL SPECIFICATIONS
SERIAL NUMBER	LOT NUMBER 0000001	Qmax 72 l/min Pmax 3 bar < 75 db S1 cos Ø 0,92 Cond. 12,5 µF	PRODUCTION YEAR
		YEAR 2003 Read instruction M0000 ML	"CE" MARK

ATTENTION

Before installing, always make sure the dispenser model is correct and suitable for the available power supply (voltage/frequency).

F DESCRIPTION OF MAIN PARTS

CUBE MC dispensers are designed for the transfer of diesel fuel for private use. Characterized by maximum safety and simplicity of use, CUBE dispensers are dependable, high-performance equipment that is quickly installed and ready for use.

Equipment and features are:

- 1 Blade type rotating self-priming pump with incorporated bypass valve.
- 2 Motor with degree of protection IP55 and heat protection, 230 V AC single phase.
- 3 Four meters of anti-static rubber tube for fuel.
- 4 Automatic type dispenser nozzle with ON/OFF switch integrated in the nozzle support.
- 5 Steel body with anti-corrosion treatment and paint finish.
- 6 Control system.
- 7 Meter

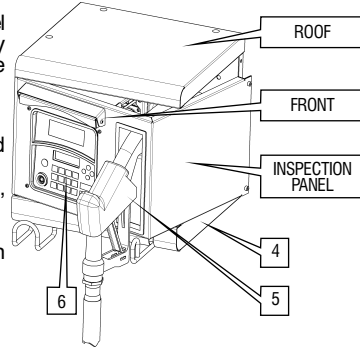

F2 PUMP UNIT

Unit with blade type self-priming electric pump, featuring bypass valve. Such a valve allows functioning for brief periods of time even with the dispensing nozzle closed.

The motor, which is directly coupled to the pump body, is asynchronous, of the closed type (degree of protection IP 55 according to EN 60034-5-86 standard) self-ventilated, single phase. For further details, refer to the relevant manuals indicated in the summary table of paragraph E1.

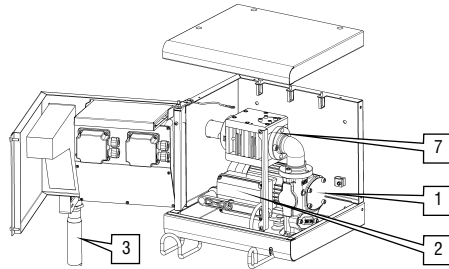

F3 PULSER METER

The K600/3 Pulser meter features a measurement system with high-precision oval gears designed for accurate fuel metering. These have a sturdy drawn aluminium structure and are complete with suction filter. They are easy to service and reliable. For further details, see the manual indicated on the summary table of paragraph E1.

F4 CONTROL SYSTEM

The electronic control system -MC- ensures the dispenser can only be used by authorised personnel. All the data relating to each dispensing operation are stored and can be transferred to a PC (optional).

For further details, see the manual indicated on the summary table of paragraph E1.

F5 NOZZLE

The nozzle supplied with CUBE MC is of automatic type; it is fitted with a shut-off device for full tank.

F6 DISPLAY UNIT COVER

To ensure adequate protection and the correct visibility of the CUBE MC display units, including in very strong light conditions, a pull-out display unit cover has been integrated in the structure. This can be lowered in case of need. **In very strong light conditions, we advise always keeping the display cover lowered when not in use.**

G TECHNICAL SPECIFICATIONS

MODEL	POWER VOLTAGE	ABSORPTION (A)	POWER (W)	FLOW RATE (l/min)
CUBE MC	230 V / 50 Hz	4.2	900	70

G1 PERMITTED USES

Transfer of diesel fuel with a viscosity from 2 to 5.35 cSt at 37.8° C and PM flash point > 55° C.

G2 USES NOT PERMITTED

The transfer of fluids with different characteristics than those indicated above is not allowed. In particular:

- Gasoline, solvents and inflammable liquids with PM < 55° C (danger of fire/explosion).
- Liquid food products (contamination of the same).
- Water (pump oxidation).
- Corrosive chemical products (pump corrosion).
- Liquids with viscosity >20 cSt (motor overload).

G3 ABSORBED POWER

The CUBE MC stations must be powered by a power line with the same RATED VOLTAGE / FREQUENCY as that indicated on the IDENTIFICATION PLATE.

The maximum acceptable variations from the electrical parameters are:

- **VOLTAGE** +/- 5%
- **FREQUENCY** +/- 2%

The IDENTIFICATION PLATE shows maximum ABSORBED POWER (in Ampères), with respect to which, the power protection appliances required by applicable standards (not supplied with the station) must be sized.

The maximum absorbed power refers to intended-use operation - DISPENSING OF DIESEL FUEL - with power supply within the above-mentioned limits.

G4 HYDRAULIC PERFORMANCE

When correctly installed and powered, and used for the purpose for which they were designed - DISPENSING OF DIESEL FUEL - the CUBE MC stations perform as follows:

- **Model CUBE MC:** **FLOW RATE MAX 70 litres/minute**

The installed pumps ensure CONTINUOUS operation of the stations.

G5 CONTROL SYSTEM PERFORMANCE

The performance of the MC control system is detailed in the M0103 manual supplied together with the CUBE MC.

G6 METERING ACCURACY

Thanks to the PULSER K600 METER and to the MC control system which ensures precise CALIBRATION, the CUBE MC stations provide the following performance:

ACCURACY: +/- 0,5% (after calibration, for flow rates above 5 litres/minute).

H INSTALLATION

H1 GENERAL

CUBE MC can be installed outside. Nevertheless, it is advisable to locate it under the shelter of a roof to ensure the dispenser's longevity and provide greater comfort during refuelling in the event of bad weather. The installation of the dispenser must be carried out by skilled personnel and performed according to the instructions provided in this chapter. Whenever CUBE MC is not installed under cover, a "display cover" is provided to protect the display and keyboard.

ATTENTION
The motors are not of an anti-explosive type. DO NOT install CUBE MC in places where there is risk of explosion.

The CUBE MC stations can be connected both to tanks above ground and tanks under ground.

H2 STATION POSITIONING

- The positioning of the SELF SERVICE must be such that it is possible to:
- Easily remove the panels to access the inner components when necessary.
 - Observe the distances and maximum differences in level between the station and the tank.
 - Securely fasten the casing to the ground on a horizontal surface.

Station positioning determines the following parameters, which distinguish each installation:

- Hp: Priming height
Ls: Total length of the suction pipe - from the foot valve to the station
(expressed in metres)

To ensure correct station operation, the following limitations must always be kept to:
Hp max: not over 3 metres
LS max: not over 15 metres

H3 MECHANICAL INSTALLATION

Before starting installation, make sure no packaging materials are trapped in the pipes. Prepare suitable stilts or fixing brackets depending on the fixing position of the CUBE MC. The tube coming from the tank must be aligned to the threaded inlet of the pump filter which is located under the CUBE MC.

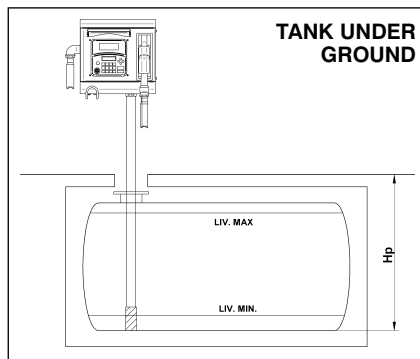
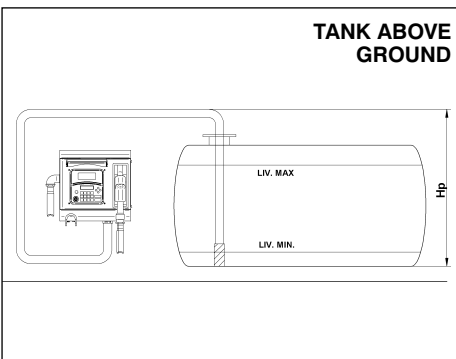

H4 HYDRAULIC CONNECTIONS

SUCTION LINE

The diameter of the "Ds" suction line must be selected according to the station model and the position of the station with respect to the tank.

With reference to the "Hp" and "Ls" values indicated at point H2, the following MINIMUM DIAMETERS of the suction pipe must always be ensured.

H4.1 MAXIMUM LENGTH OF THE SUCTION PIPES

The maximum length of the tubing, the diameter of the tubing, the difference in height, are parameters that are tightly linked to creating suction conditions. The latter must not be such as to create backpressure greater than 0.6 bar. It follows as a consequence that, after respecting the minimum diameter of the tubing specified in the "Recommendations and Warnings" below, the length of the tubing decreases as the difference in height that the diesel fuel must overcome increases and vice versa: in fact, the back pressure progressively increases by 0.08 bar for every meter increase in the static height of the pump with respect to the level of the diesel fuel in the tank.

RECOMMENDATIONS AND WARNINGS:

- The suction pipe must resist a pressure of at least 10 bar and must be of a diameter NOT LOWER THAN 1" 1/4.
- The tubing must be suitable to functioning under backpressure.
- Use tubing and accessories suitable for use with diesel fuel. Materials that are not suitable for use with diesel fuel can cause damage to the pump, harm people and cause pollution.
- Any curves in the suction pipes must be of the widest radius possible to limit the loss of head.
- Make sure that the suction pipe is clean and free of scum.

ATTENTION

In all cases, always take the following PRECAUTIONS:

- Use pipes and connections suitable for vacuum operation.
- Use pipes and accessories suitable for use with diesel fuel. Materials that are not suitable for such use can cause serious damage to the pump or injury to people; they can also be the cause of pollution.
- Do not use conical threaded connectors that could cause damage to the threaded connector on the pump filter.
- Use large-radius bends so as to reduce flow resistance to a minimum.
- Make sure that the suction pipe is clean and free of scum.
- At the end of the suction pipe, always fit a FOOT VALVE complete with FILTER. The valve must be placed on the bottom of the tank and be of the SAME DIAMETER as the pipe.
- Before starting installation, make sure no packaging materials are trapped in the pipes.

H5 ELECTRICAL CONNECTIONS

The power connections must be workmanlike performed by skilled personnel, in strict compliance with the laws applicable in the country of installation and with the instructions on the wiring diagrams in this manual.

Maximum acceptable electrical parameter variations are $\pm 5\%$.

ATTENTION

The CUBE MC dispenser does not feature overload cutouts and, consequently, a switchboard must be fitted upstream of the CUBE MC complete with residual current circuit breaker suitable for the type of CUBE MC to be installed.

CUBE MC features a terminal board cover. Inside this cover are the terminals which the installer must connect up to:

- The mains power line
- The RS 485 data line to the PC (optional).

The connector block, accessible through the front panel opening, is already wired up to the CUBE MC components, according to the block diagram shown below.

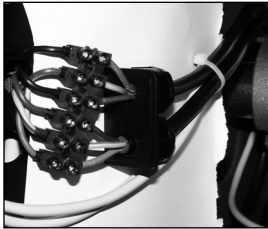
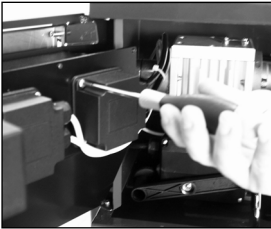

- 1- Remove the right terminal board cover.
- 2- Connect the cables as shown in the diagram.
- 3- Close the terminal board cover box again.

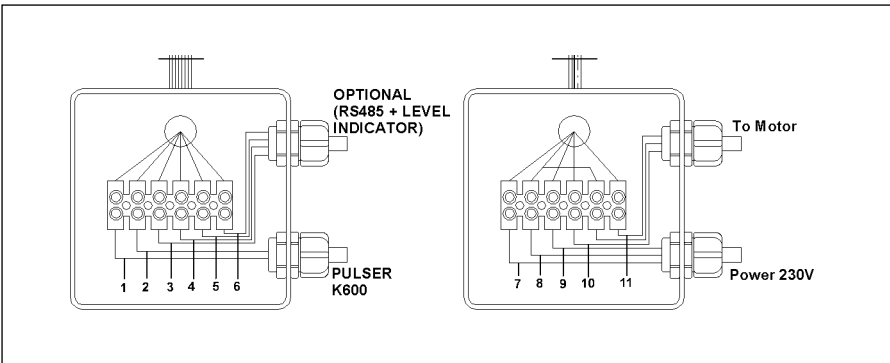

NOTE:

The parts indicated in the diagram are the only connections to be made by the customer:

- Connection to power mains (230V)
- RS485 output to PC (OPTIONAL).

ATTENTION

For CUBE MC commissioning, no further power connections are required. All the electronic components housed in the MC BOX are already wired up and factory tested.

It is therefore NEVER necessary for the installer or station manager to open the MC BOX except to replace the protection fuses housed on the I/O card (see photo below).

Below are the main connections and the fuses to be replaced by skilled service technicians only.

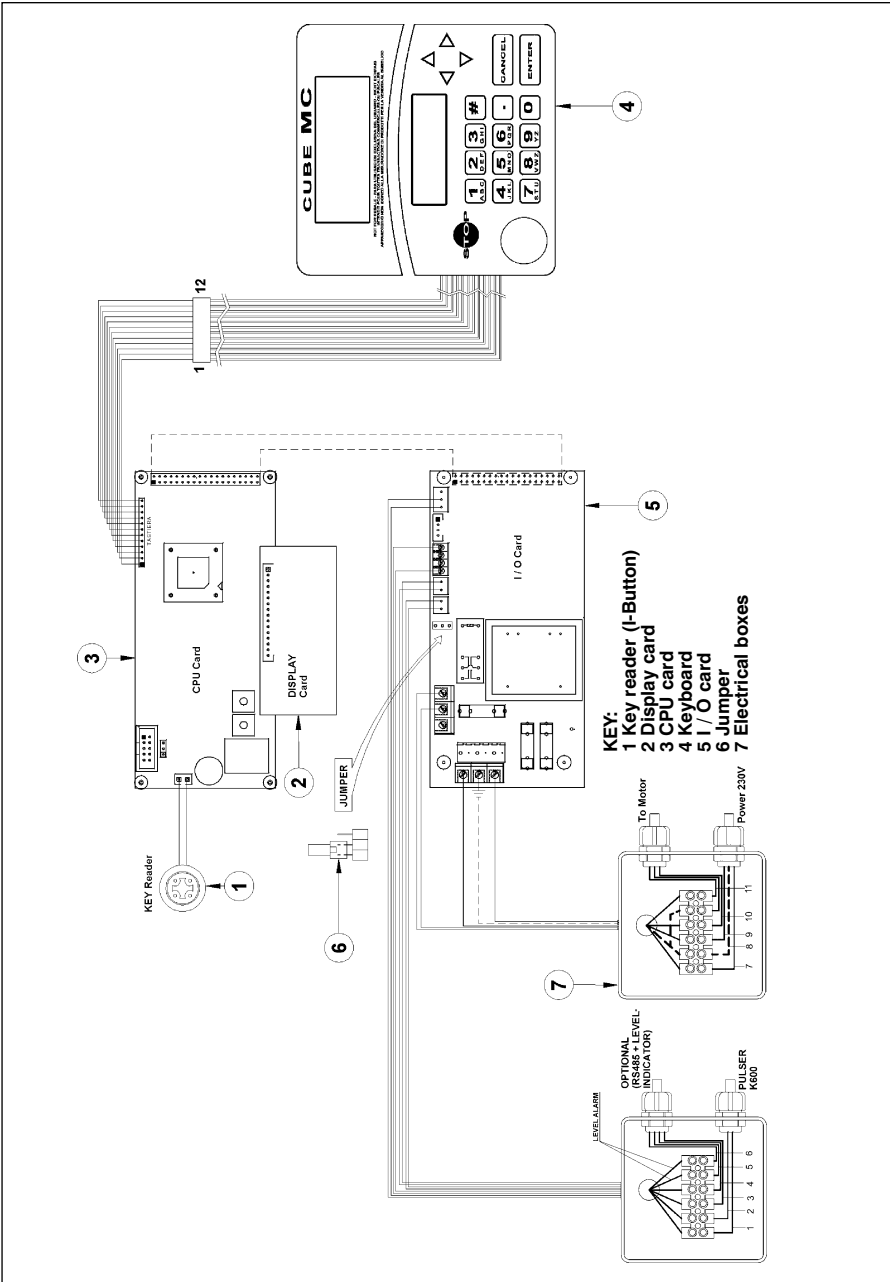

I COMMISSIONING

To correctly commission the CUBE MC the sequence of operations indicated below must be followed and the MC control system functions must be known (see attached manual).

I1 ELECTRICAL POWER SUPPLY

Once the power connections have been made, the CUBE MC can be energised by means of the master switch to be fitted by the installer on the upstream line. Switching on of the MC system will be indicated by the lighting up of the two backlit LCDs fitted on the front. Even when the nozzle is taken out of its seat, the pump WILL NOT start as it has not been enabled by the MC system.

I2 WETTING THE PUMP

CUBE MC features a self-priming pump that makes first startup easier. To start the appliance, the suction pipe need not therefore be completely full of diesel fuel. For quick priming, especially in the case of installations distinguished by a considerable difference in level between the pump and the tank, it is however important for the pump to be "wetted", meaning that there must be a small quantity of diesel fuel inside the impeller chamber.

The pump is supplied adequately "wetted" and ready for use. If however the installer considers the pump to be totally dry, perhaps due to prolonged storage, he will have to wet it as he thinks best.

I3 STATION CONFIGURATION

Every CUBE MC station can be adapted to the specific requirements of the station manager. To do this the MC control system must be CONFIGURED.

ATTENTION

MC configuration is crucial and must be done by skilled personnel.

To perform this operation, the MC manual must be carefully and thoroughly read.

After completing configuration, user PIN CODES can be assigned to the persons charged with using CUBE MC, in accordance with the detailed information in the MC manual.

I4 DISENGAGING THE "MC" SYSTEM

All the CUBE MC functions are controlled by the MC control system. The MC system can nevertheless be disengaged for any startup or maintenance activities requiring repeated pump starting.

In these case, it is often convenient to simplify pump startup by not having to enter any code and record any dispensing data.

To do this, a JUMPER has been fitted on the card that permits switching from AUTOMATIC mode (code request to access dispensing) to MANUAL mode (no code request).

ATTENTION

The jumper is only accessible by opening the front panel and is positioned as shown in the photo. In this operating mode, MC does not record any data relating to performed dispensing operations.

BEFORE ACCESSING THIS JUMPER, ALWAYS INTERRUPT THE POWER SUPPLY

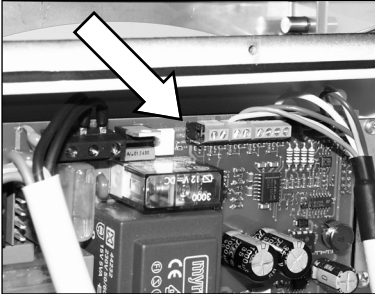

In MANUAL mode:

- The MC LCDs could be off or continue to display whatever was showing at the time of switchover from AUTO to MAN.
- To start the pump, no PIN CODE is required; the pump will start as soon as the nozzle is taken off its seat and will stop when the nozzle is put back.
- The quantity dispensed by CUBE MC is not indicated in any way.

15 FIRST PRIMING

To prime the pump:

- Take the nozzle off its seat
- Enter the previously assigned PIN CODE (if the jumper is on)
- Lift the control lever
- The pump will start immediately and will continue running indefinitely until the control lever is moved to OFF position.



Operate the lever of the automatic nozzle, keeping the spout inside an adequate container or the same suction tank.

Air will first of all come out of the nozzle and then DIESEL FUEL will gradually begin to flow.

ATTENTION

*The first priming of the pump must be done by skilled personnel who must monitor all the various stages involved.
If only air continues to come out after more than two minutes, STOP THE PUMP and make sure:*

- This is not working dry, but is at least "wetted" with diesel fuel.
- The suction pipe prevents any air from infiltrating and that this is completely submerged.
- The filters are not blocked.
- The suction and/or supply lines are not blocked.
- Installation (level difference, diameter and pipe length) is within the limits indicated at point H4.
- The disconnection valve is closed.

Continue dispensing until the flow is regular and air free.

Position the control lever in OFF position:

- The pump stops.

Place the nozzle back in its seat.

I6 METER CALIBRATION

Before using the CUBE MC station, check the METER ACCURACY.

For this purpose, proceed as follows:

- Enter a previously enabled USER PIN code.
- Run the fuel into a calibrated container.
- Compare the quantity of dispensed diesel fuel using a calibrated container.

If accuracy is NOT satisfactory, proceed to CALIBRATE THE METER according to the instructions in the specific manual.

ATTENTION

To correctly check accuracy, always keep to the following instructions:

- *Use a precision sample container, featuring a graduated scale, with a capacity of at least 20 litres.*
- *Before making the check, always make sure you have eliminated all the air from the system and then run the fuel until a full and regular flow is achieved.*
- *Dispense continuously at CUBE MC maximum flow rate*
- *Stop the flow by quickly closing the nozzle.*
- *Reach the graduated area of the sample container, avoiding prolonged dispensing at low flow rate, but rather performing short dispensing operations at maximum flow rate.*
- *Compare the reading provided by the container, with that provided by CUBE MC, after waiting for all the froth to disappear.*

ATTENTION

Differences of up to 1/10 of a litre affecting the dispensing of 20 litres of fluid fall within the guaranteed accuracy of +/- 0.5%.

L DAILY USE

Thanks to the MC control system, all the CUBE MC models provide access to authorised users only.

MC acknowledges User authorisation by means of two alternative systems:

- The entering of a 4-figure SECRET CODE (PIN CODE).
- The fitting of an electronic key (OPTIONAL).

ATTENTION

All the users to whom a PIN CODE is assigned must be adequately instructed and be at least acquainted with the contents of this chapter.

The configuration of the MC system permits requiring the User to enter further optional data (vehicle licence plate, mileage, quantity to be dispensed).
See MC manual (M0103) for details.

If these options are not set, MC recognises an authorised PIN CODE and immediately enables the pump to dispense fuel.

ATTENTION

Such enabling does not result in immediate pump startup. The pump is in fact controlled by a switch (positioned in the nozzle seat) operated by the user.

The pump will start (if previously enabled) just as soon as the control lever is moved to ON position, while it switches off as soon as the control lever is moved to OFF position.

No further manual operation is required to start or stop the pump.

L1 FUEL DISPENSING

ATTENTION

Fuel MUST ONLY be dispensed under the careful control of the User.

In the case of the simplest configuration (no optional data required), the fuel dispensing procedure is the following:

1 Enter PIN CODE

If the MC recognises an authorised code, it displays the following messages and enables the pump.



- 2 Move the control lever to ON position (see photo on page 17)
MC operates the pump.

ATTENTION

Never operate the nozzle lever before placing this in the fuel container.

- 3 Operate the nozzle lever to start the dispensing operation
MC indicates the dispensed quantity.

ATTENTION

The dispensing operation can be interrupted as required. If the interruption continues for over a certain time (which can be set as required by the station manager during MC configuration) the pump is stopped and disabled. To continue dispensing fuel, the various steps will have to be repeated starting from no. 1.

- 4 After terminating the dispensing operation, rewind the hose around the hose carrier, move the control lever to OFF position and put the nozzle back in its seat.
MC stops the pump.

M ROUTINE MAINTENANCE

CUBE MC has been designed so as to require minimum maintenance. For utmost station efficiency and safety, the following inspection and ROUTINE maintenance operations should however be regularly performed.

M1 OPENING AND CLOSING THE CUBE MC

- Lower the display cover
- Loosen the 2 screws on the right side (marked by the arrows)
- Open the inspection side of the CUBE MC
- To reclose it, perform these steps in reverse order.

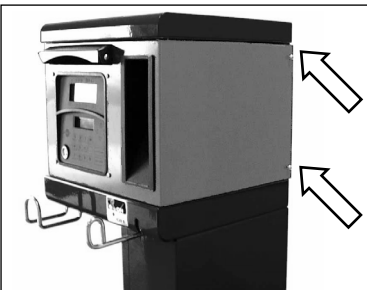

M2 PUMP AND PIPES

Check the pump, the pipes and other internal components of the station and keep them clean.

Make sure there are no leaks in the flanged or threaded connections and that the hoses are in perfect condition (not damaged) - refer to the Panther M0042 and K600, M0046 manual.

M3 DISPENSER PIPE AND NOZZLE

Keep the dispenser pipe and nozzle clean and make sure especially that:

- The pipe is in perfect condition and has not been damaged by vehicle transit.
- The threaded connections are tight and not leaking.
- The swivel connections (at dispenser exit and on the nozzle) are turning freely and do not show leaks.
- The hole of the automatic stop probe at the end of the pipe nozzle spout.

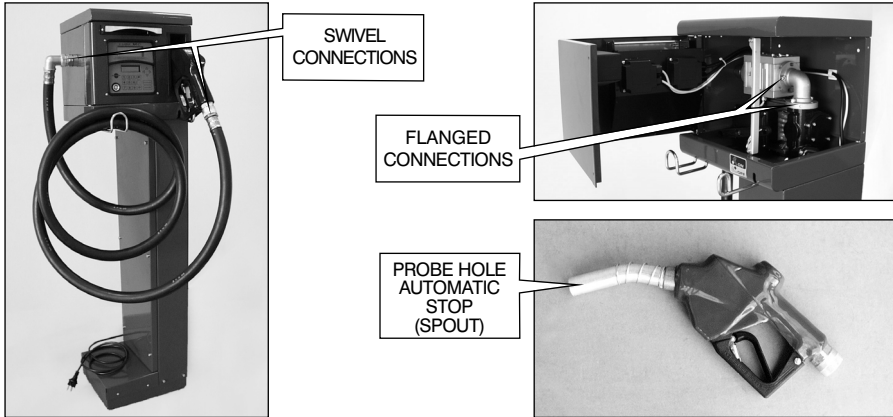

M4 "MC" CONTROL SYSTEM

The MC system is maintenance free. To control it however, refer to the dedicated M0103 manual provided.

M5 FILTERS

CUBE MC features a number of filters having different functions. The inspection and cleaning (or replacement) of each filter is crucial to ensure:

- The protection of the various station components (pulsar, pump, nozzle).
- Station performance remains high over the years (maximum flow rate).
- Protection of the engines using the dispensed diesel fuel.

ATTENTION

Dirty or partially blocked filters can increase flow resistance and cause a considerable reduction in the maximum flow rate of the pump.

Dirty or blocked pump suction filters also cause a big increase in vacuum during suction and this in turn can make the pump particularly noisy.

M5.2 PUMP FILTER

This is fitted in the pump body, as a standard PANTHER pump fitting.

To inspect and clean it:

- 1 Loosen the two filter cover screws and take the cover off.
- 2 Take out the mesh filter with the aid of a pair of pliers.
- 3 If the filter needs cleaning, wash and blow it.
- 4 Put the filter carefully back in its housing in the pump body, making sure it does not protrude from the cover housing.
- 5 Check and clean the flat seal, reposition the cover and tighten the screws.

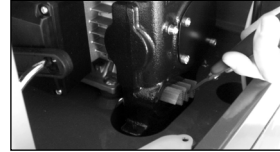
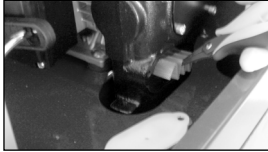

M5.3 PULSER FILTER

The pulser filter represents a further protection against the risk of foreign bodies entering the oval-gear pulser.

Because this filter is fitted downstream of the suction filter, it does not require regular inspection and cleaning.

Should the need arise however and/or in case of special maintenance, it can be cleaned as described in the PULSER MANUAL, after removing the roof of CUBE MC (if necessary) by means of its relevant upper screws (see exploded view, pos.14).

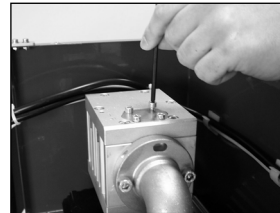
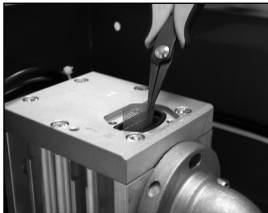
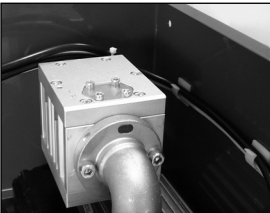

M6 PULSER

The meter / pulser is a carefully-made and assembled high-precision measuring instrument. It normally requires no routine maintenance.

CALIBRATION, normally done during station installation, can be repeated whenever accuracy checks, to be performed every 3/6 months, show the need.

CALIBRATION is done electronically by means of the MC control system, and does not require any adjustments to be made to the pulser.

For all details, refer to the K600, M0046 meter manual.

M7 TROUBLESHOOTING

PROBLEM	POSSIBLE CAUSES	POSSIBLE SOLUTIONS
THE MOTOR IS NOT TURNING	Lack of electric power	<ul style="list-style-type: none"> - Make sure the operating lever is in ON position - Recock the external residual current circuit-breaker - Check the electrical connections
	Fuse burned out	Change the fuses on the switchboard
	Motor problems	If the rotor is jammed, dismount and check for damage and obstructions, then remount. Contact the Service Department
MOTOR WON'T START WITH NOZZLE CLOSED	Electric voltage too low	Check that the voltage is not more than 5% below the nominal voltage
LOW OR NO FLOW RATE	Excessive suction pressure	Lower the CUBE MC with respect to the tank or increase the diameter of the tubing
	High loss of head	Use shorter tubing or of greater diameter
	Suction pipe resting on the bottom of the tank	Raise the suction pipe
	Low level in the suction tank	Refill the tank
	Air entering the suction pipe or in the pump	Check the connections seal in the tubing and the level of diesel fuel in the tank
	Motor low rotation speed	Check the voltage at the motor: adjust the voltage and/or use cables of greater cross-section
	Check valve blocked	Clean or replace
	Tank filter clogged	Clean the filter
	Pump filter clogged	Clean the filter
	Fluid leaking	Check the seals of the connections and the condition of the rubber tubes.
Meter chamber obstructed	Clean the meter chamber	
METER NOT ACCURATE ENOUGH	Air in the suction line	Check the seals of the connections
	Lack of calibration	Calibrate the meter (see M0033)
THE NOZZLE TRIPS TOO OFTEN	Automatic stop probe hole blocked	Remove any dirt and/or blockages from the automatic stop probe hole

N SPECIAL MAINTENANCE

In order to change the fuses inside the electronic board panel, we suggest proceeding as follows:

- Interrupt power to the CUBE MC
- Remove the cover of the MC BOX panel
- Replace the burnt out fuses
- Close the panel again
- Restore power to the CUBE MC.

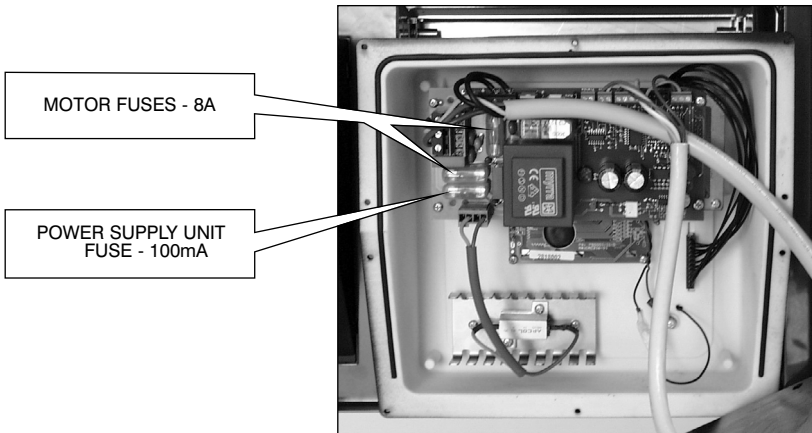
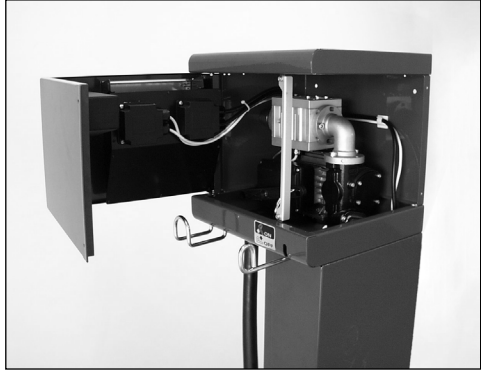

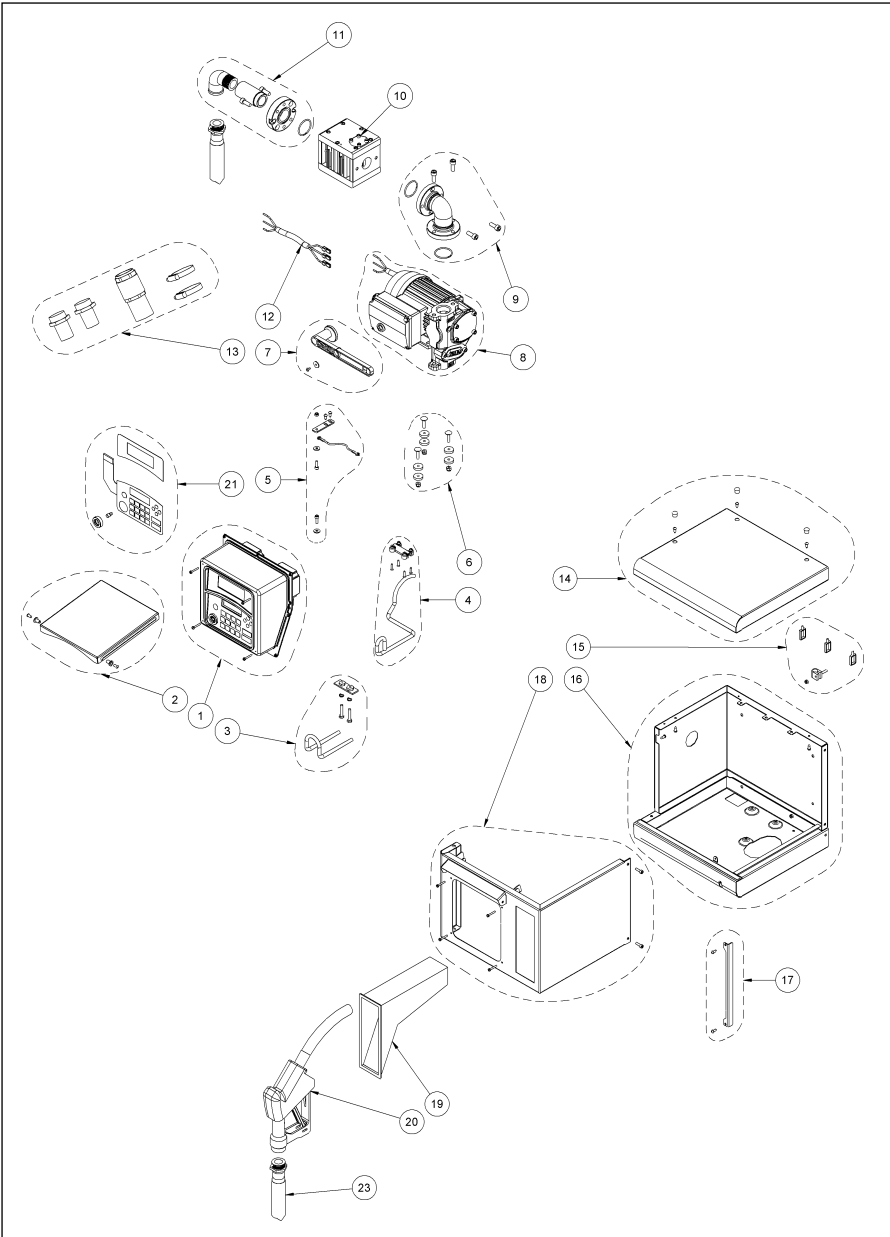
O CUBE MC SPARE PARTS
O1 CUBE MC EXPLODED VIEW

02 LIST OF CUBE MC COMPONENTS

<i>Position</i>	<i>Description</i>	<i>Quantity</i>
1	BOARD PANEL ASSEMBLY KIT	1
2	CUBE MC SUN GUARD KIT	1
3	HOSE SUPPORT KIT	1
4	EQUALISER OPERATION KIT	1
5	CUBE MC HINGE KIT	1
6	PUMP FASTENING KIT	1
7	CUBE MC OPERATING KIT	1
8	PANTHER 72 UNIT - 230V/50HZ	1
9	CUBE 70/33 MANIFOLD KIT	1
10	KIT K600/3 + CABLE 0.5 M	1
11	CUBE MC DELIVERY KIT	1
12	PUMP CABLE/MC BOX FOR CUBE MC KIT	1
13	FOOT VALVE KIT	1
14	CUBE MC ROOF KIT	1
15	CUBE MC CABLE RETAINER KIT	1
16	CUBE MC BASE KIT	1
17	CUBE MC STRUCTURE REINFORCEMENT KIT	1
18	CUBE MC FRONT DOOR KIT	1
19	NOZZLE SEAT CUBE 50	1
20	AUTOMATIC NOZZLE 60 1in F BLACK	1
21	KEYBOARD + SENSOR KIT	1
22	FUSE KIT	1

MANUFACTURER: **PIUSI S.p.A.**

DOCUMENT TYPE: **General description and instructions
for its installation, activation,
use and maintenance**

EDITION: **Bullettin M0104 Rev. 4**

PRODUCT: **Diesel fuel dispenser for private use with meter**

MODEL: **All the models of the CUBE MC range,
with single-phase/three-phase
mechanical/electronic meter,
with various voltages/frequencies**

CONFORMITY: **CE MARK**
(see Declaration of conformity, page 28)

TECHNICAL SUPPORT: **Provided by the Service Departments
of our Authorized Resellers**

The information contained in this manual is provided by the Manufacturer, who reserves the right to make changes without prior notice.

Impaginazione e grafica: **NEGRINI&VARETTO**, Modena
www.negrinievetto.com

Traduzioni: **FERRARI STUDIO**, Suzzara (Mn)
www.ferraristudio.it

Stampa: **LA CITTADINA**, Gianico (Bs)
www.lacittadina.it

PETRO INDUSTRIAL



www.petroind.com

*Authorized reseller's stamp
Timbre du revendeur autorisé
Stempel des autorisierten Vertragshändlers
Timbro del rivenditore autorizzato*

PIUSI

®

M 0104 ITUK Rev. 4