

Size	Total Fill Level (L)	Safe Fill Level (L) 95%	Length (mm)	Width (mm)	Height (mm)
CUBE6300	6300L	5950L	3580	2246	1219

07					
06					
05					
04					
03					
02					
01					
REV:	DATE:	REVISION:	DRAWN:	CHECKED:	APPROVED:

Note:
 > Designed and approved to AS1940 / AS1692 / AS1657
 > All welding to AS1554.1



Material:
 Weight: 2122.07KG

DRAWN: DATE: 2016/7/11
 CHECKED: DATE:
 CLIENT: DATE:
 APPROVED: DATE:

TITLE: PETRO 6300L SELF BUNDED BAFFLED CUBE
 DRAWING NO. :
 PURCHASE ORDER NO. :
 REV: 01
 SHEET: 1 of 3
 Scale: No scale

A3



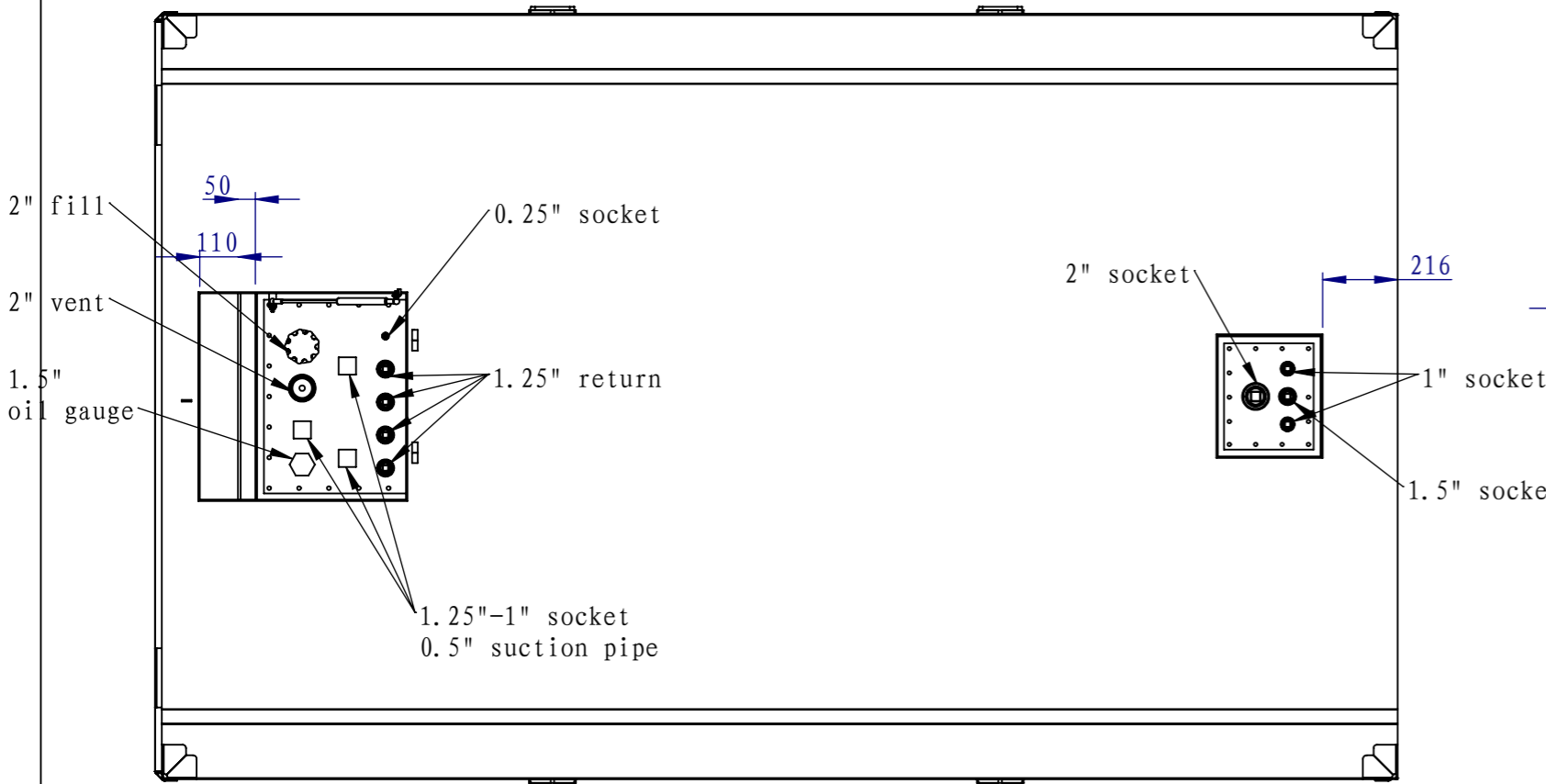
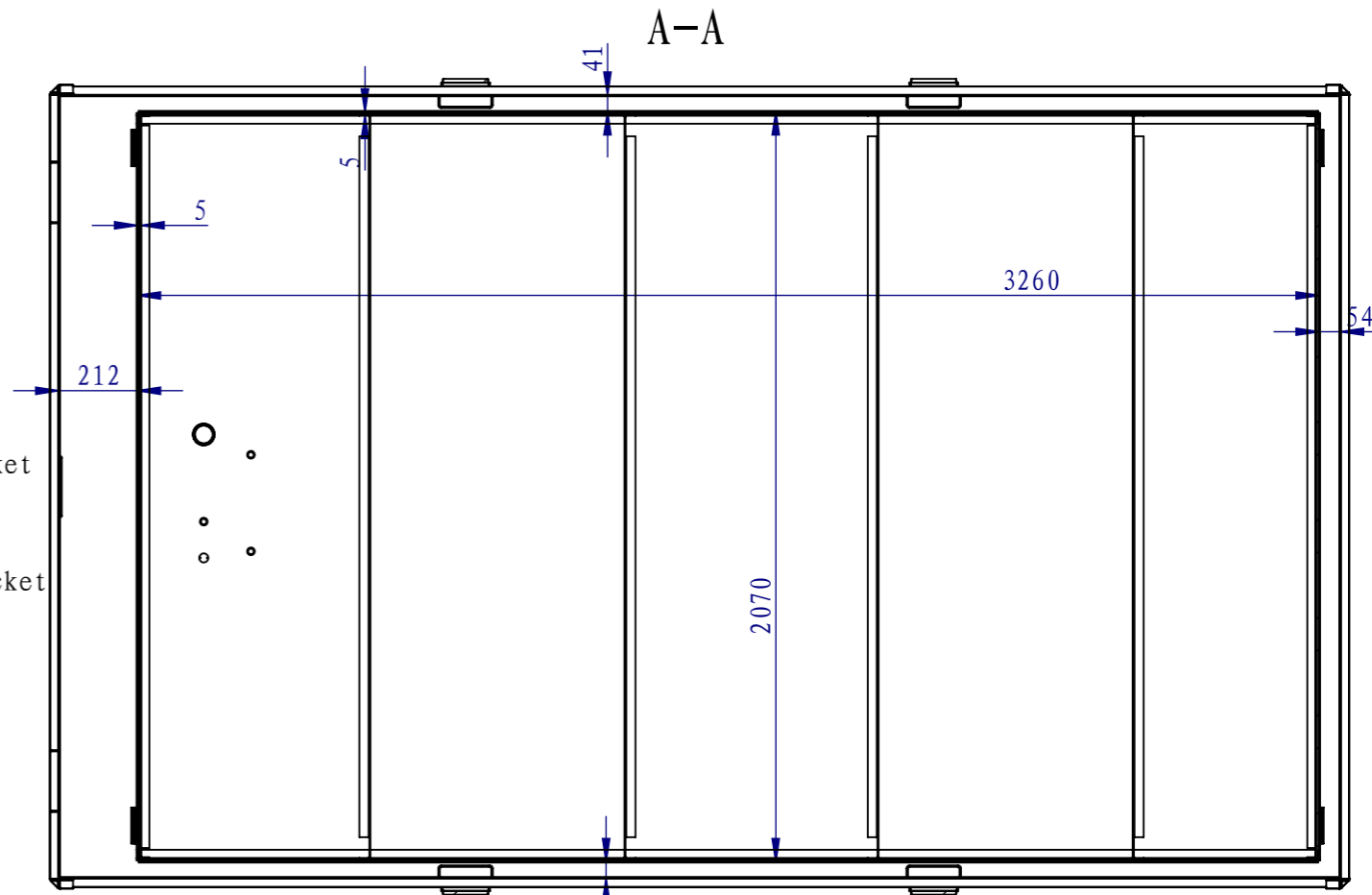
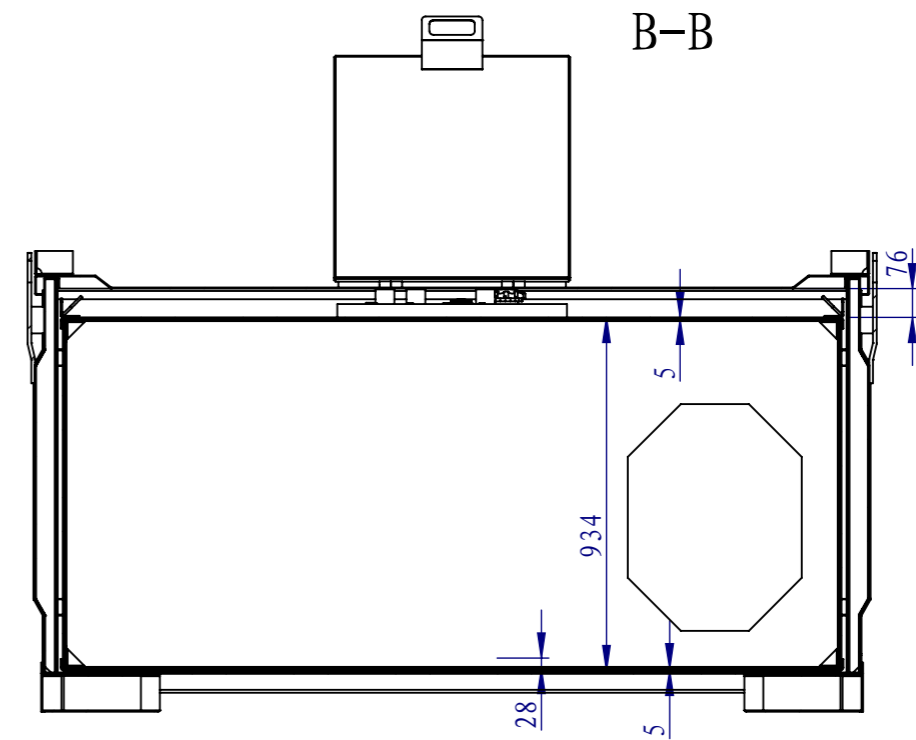
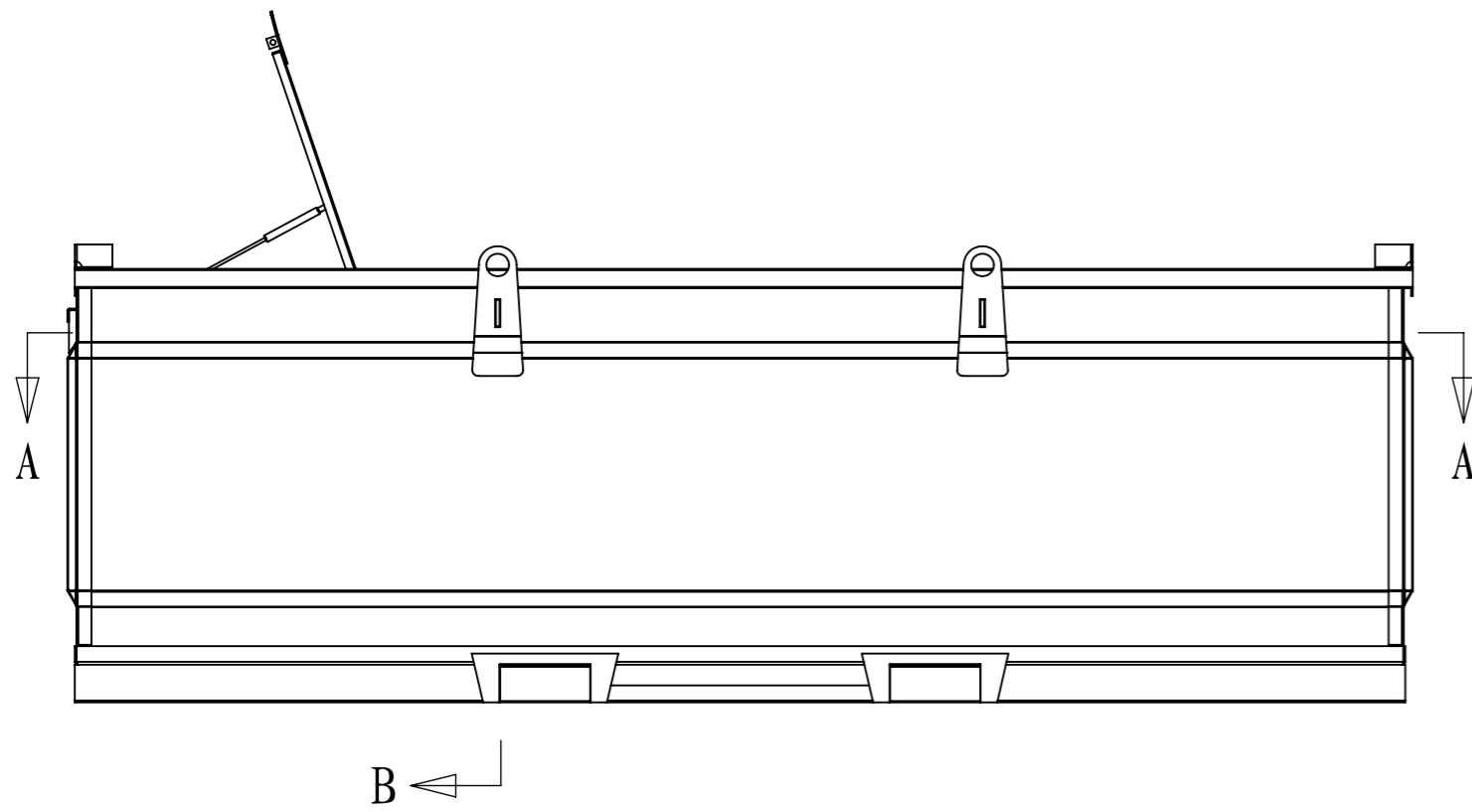

07					
06					
05					
04					
03					
02					
01					
REV:	DATE:	REVISION:	DRAWN:	CHECKED:	APPROVED:

Note:
1. All thread is BSP ;



Material: _____
Weight: 2122.07KG

DRAWN: _____
CHECKED: _____
CLIENT: _____
APPROVED: _____

SAVING DATE: 2016/7/11
DATE: _____
DATE: _____
DATE: _____

TITLE: PETRO 6300L SELF BUNDED BAFFLED CUBE

DRAWING NO. : _____

PURCHASE ORDER NO. : _____

REV: _____

SHEET: 2 of 3

Scale: No scale

A3



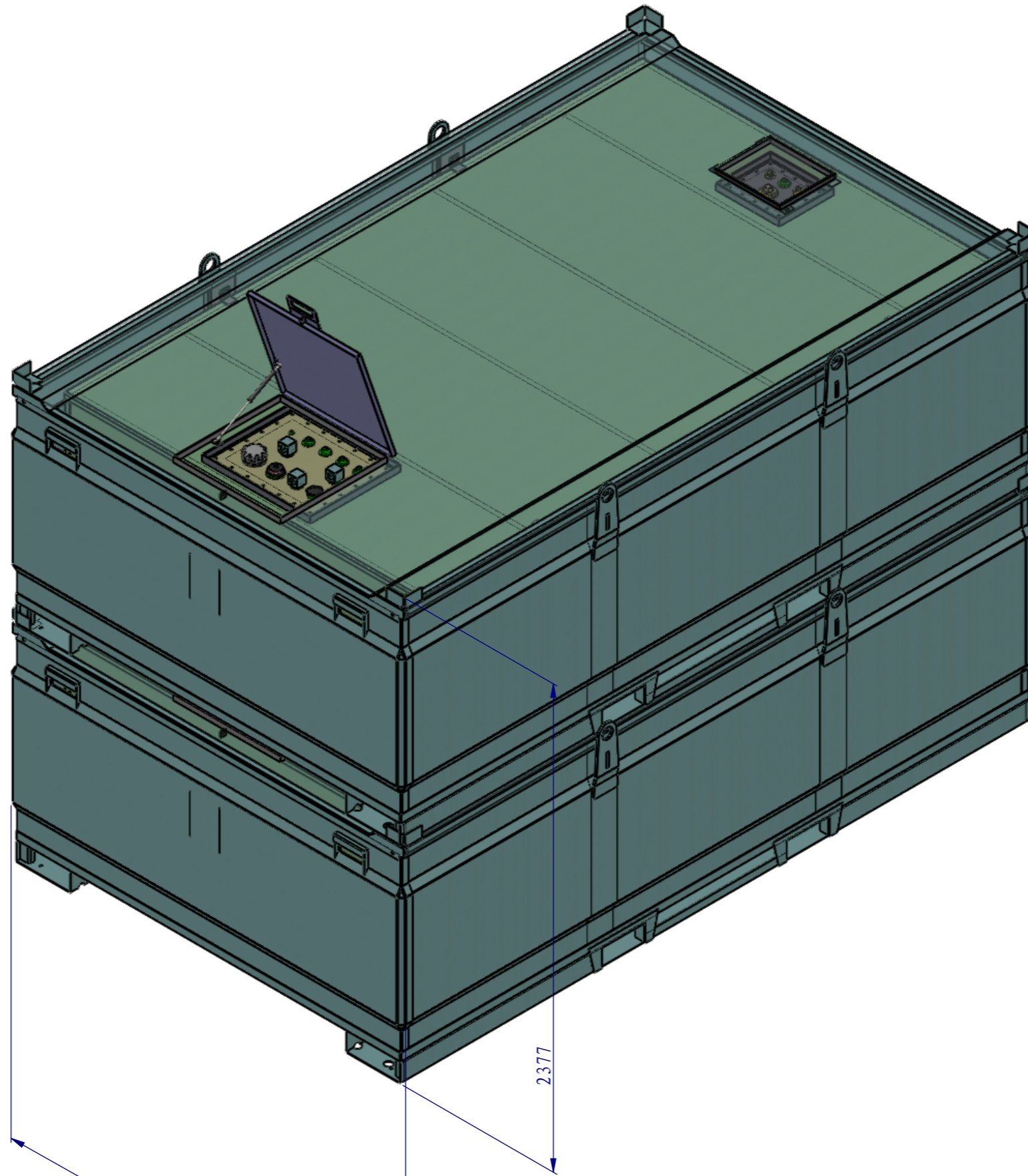

07					
06					
05					
04					
03					
02					
01					
REV:	DATE:	REVISION:	DRAWN:	CHECKED:	APPROVED:

Note:
 > Designed and approved to AS1940 / AS1692 / AS1657
 > All welding to AS1554.1



Material:
 Weight: 4232.99KG

DRAWN: DATE: 2016/7/11
 CHECKED: DATE:
 CLIENT: DATE:
 APPROVED: DATE:

TITLE: PETRO 6300L SELF BUNDED BAFFLED CUBE
 DRAWING NO. :
 PURCHASE ORDER NO. :

REV: 01
 SHEET: 3 of 3
 Scale: No scale

A3

