

INSTRUCTION MANUAL

Oval Gear Medium Capacity Positive Displacement Mechanical Flowmeters

Models: 1" (025), 1 1/2" (040), 2" (050) & 2" (050E)



PETRO INDUSTRIAL



petroind.com

Contents

1.0	General	2
1.1	Overview	2
1.2	Operating Princial	3
1.3	Specifications	4
2.0	Installation	5
2.1	Mechanical Installation	5
2.1.1	Meter and Totaliser Orientation	5
2.1.2	Flow Conditioning and Locations	6
3.0	Commissioning	7
4.0	Maintenance	7
4.1	Disassembly Of Meter and Exploded View	8
4.2	Inspection	9
4.3	Re-assembly of meter	9
4.4	Spare parts list	10
5.0	Fault Finding	11
5.1	Trouble shooting	12

1.1 Overview

The Oval Gear meter is a precise positive displacement flowmeter incorporating a pair of oval geared rotors. These meters are capable of measuring the flow of a broad range of clean liquids. Stainless Steel flowmeters are suited to most water based products and chemicals and aluminum meters are suitable for fuels, fuel oils & lubricating liquids.

Mechanical oval gear meters are fitted with both a Primary and Secondary rotor. The Primary rotor has an extension shaft with pinion gear that drives the mechanical register via a reduction gearbox.

This series of 1" (25mm), 1½" (40mm) and 2" (50mm) flowmeters is available with either an M3 (4 Digit) register which reads in Litres or an M4 (4 Digit) register which reads in US Gallons .

The M3 register fitted to 1" (25mm) meter has:

4 digit resettable totalizer reading to 9999.9 Litres (decimal place is read off vertical Vernier scale). 8 digit accumulative totalizer reading to 99,999,999 Litres.

The M4 register fitted to 1" (25mm) meter has:

4 digit resettable totalizer reading to 9999.9 US Gallons (decimal place is read off vertical Vernier scale). 8 digit accumulative totalizer reading to 99,999,999 US Gallons.

The M3 register fitted to 1½" (40mm) & 2" (50mm) meter has:

4 digit resettable totalizer reading to 99,999 Litres (x 1 Litre is read off vertical Vernier scale). 8 digit accumulative totalizer reading to 999,999,99 (0) Litres. (x 1 Digit not shown)

The M4 register fitted to 1W (40mm) & 2" (50mm) meter has:

4 digit resettable totalizer reading to 99,999 US Gallons (x 1 US Gallon is read off vertical Vernier scale). 8 digit accumulative totalizer reading to 999,999,99 (0) US Gallons. (x 1 Digit not shown)

The 1½" (40mm) and 2" (50mm) flowmeters are also available with an optional V series 5 digit mechanical register (Litres ONLY). The V-series register is not available for the 1" (25mm) mechanical flowmeter due insufficient torque output from this smaller flowmeter to meet the torque required to drive the V-series mechanical register.

The V1 register fitted to 1w (40mm) & 2" (50mm) meter has:

5 digit resettable totalizer reading to 999,999 Litres (Last x 1 Litre is read off vertical Vernier scale). 8 digit accumulative totalizer reading to 999,999,99 (0) Litres. (x 1 Digit not shown)

The V1 register is ONLY available in LITRE increments and is NOT available for US Gallons

1.2 Operating Principle

The Oval gear are positive displacement flowmeters where the passage of liquid causes two oval geared rotors to rotate within a precision measuring chamber and with each rotation a fixed volume of liquid is displaced passing through the meter. Magnets embedded within the rotors initiate a high resolution pulse train output. The pulse output can be wired directly to process control and monitoring equipment or can be used as an input to instruments supplied with or fitted directly to the meter.

The benefits of this technology allow precise flow measurement and dispensing of most clean liquids irrespective of their conductivity, with other liquid characteristics having nil or minimal effect on meter performance. This metering technology does not require flow profile conditioning as required with alternative flow technologies making the installation relatively compact and low cost.

OPERATION:

Liquid travels around the crescent shaped chambers created by the rotational movement of the rotors

liquid entering measuring chamber

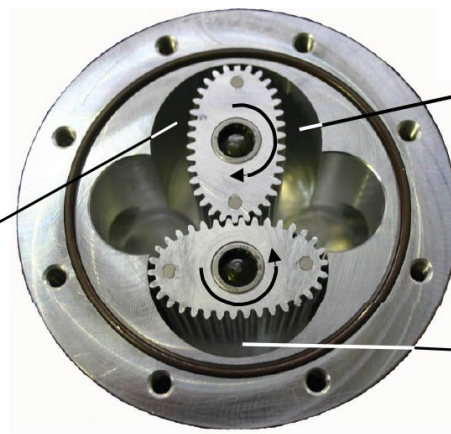

liquid exits the measuring chamber



liquid in transit

Oval Principle

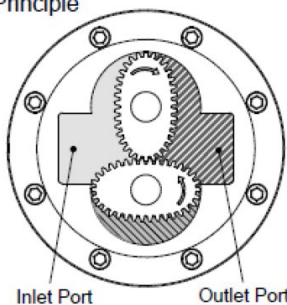

Inlet Port

Outlet Port

□ Liquid Entering the Measuring Chamber

▨ Liquid in Transition

▩ Liquid Leaving the Measuring Chamber

1.3 Specifications

Model Prefix:	025 (1")	040 (1.5")	050 (2")	050E (2")
Nominal size (inches)	25mm (1")	40mm (1.5")	50mm (2")	50mm (2")
*Flow range - LPM - GPM	10 - 150	15 - 250	30 - 450	35 - 580
	2.6 - 40	2.6 - 66	8 - 120	9 - 150
**Accuracy @ 3cp	± 1% of reading with M - series mechanical registers or ± 0.5% of reading with V-series register (040, 050 and 050E)			
Repeatability	typically ± 0.03%			
Temperature range	-20°C ~ +80°C (-4°F ~ +176°F), refer factory for lower temperature			
Maximum Pressure	(Threaded meters) bar (PSI)			
Aluminium meters	40 (580)	30 (440)	20 (300)	20 (300)
316 stainless steel	40 (580)	30 (440)	30 (440)	-
Ductile iron	-			
Types of mechanical register	M3 = Litres; M4 = USG; V-Series = Litres			
Protection class	IP65 (M Series) & IP 53/5 (V Series) Registers			
Displays	accumulative & resettable totals			
4 digit reset mechanical totaliser	9,999.9 LPG	99,999 LPG		
5 digit V-series reset register	999,999 LPG			
Accumulative totaliser capacities	8 digit accumulative (M Series and V Series Registers)			

* Maximum flow is to be reduced as viscosity increases, see flow de-rating guide.
Maximum recommended pressure drop is 100Kpa. (15 psi).

2.0 Installation

2.1 Mechanical Installation *Prior to installing the meter check:*

The fluid is compatible with the meter materials of construction using appropriate information such as fluid compatibility charts and site experience.

Application and process conditions are compatible with the meter specifications. Minimum and maximum flows are within the meter specified range including any in-situ cleaning processes. When metering viscous liquids the maximum allowable flow may need to be reduced to ensure the pressure drop across the meter does not exceed 100 kPa (1 Barg, 15 PSIG).

Process temperature and pressure does not exceed meter ratings.

The meter is not exposed to process temperatures and pressures that will cause the liquid medium to gasify (flash) within the meter.

2.1.1 Meter and totaliser orientation

The flowmeter **MUST** be mounted so that the rotor shafts are in a horizontal plane. This is achieved by mounting the meter so that the mechanical display is facing the user in a horizontal direction, it should never point towards the sky or towards the ground. If installed incorrectly the weight of the rotors will bear down on the lower end of the measuring chamber.

CORRECT ORIENTATION



Liquid can flow into the meter from either a horizontal or vertical direction. For vertical flow installations the most common orientation is for the liquid to rise through the meter (i.e. travel from bottom to top) to assist in air or entrained gas elimination. Be sure to observe flow direction Arrow marking.

Each meter is supplied from the factory with the totaliser orientated to suit a Uni-directional horizontal pipe run, should the installation require the opposite flow direction, or have a vertical pipe run, the totaliser may be rotated in increments of 90° to suit the flow direction of the installation.

Note that the flow direction of the flowmeter is set by the flowmeter gearbox, and cannot be changed by rotating the mechanical display. The flowmeter must be installed with the correct flow orientation to suit the arrow marked on the meter, and the display rotated to allow the operator to read the digits.

In order to rotate the display follow the instructions in section 4.1 (page 8) up to the point of removing the 4 x lower housing screws. Once the 4 x lower housing screws are removed, the lower housing can be rotated in increments of 90 degrees (the register plate does not require rotation), and the screws reinstalled. Once the lower housing is oriented to suit your requirements, reassemble the mechanical display the opposite of disassembly, taking care that the bevel gear in the mechanical counter assembly correctly meshes with the mating bevel gear on the register plate.

2.1.2 Flow Conditioning and Locations

Strainer: It is recommended to INSTALL a 100mesh (150 micron) strainer immediately upstream of (prior to) the meter. Strainers are available from the factory.

Flow conditioning: The flowmeter does not require any flow conditioning, therefore straight pipe runs before or after the meter are not required. If required, the pipe size about the meter can be altered to suit the installation.

Locations: The flowmeter is preferred to be fitted upstream of any flow control and/or shut off valve, this prevents free discharge from the meter and minimizes the risk of drainage and air entrapment which can result in erroneous readings or damage the meter on start up.

Process or safety critical meters should be installed in a by-pass section of pipe with isolation valves to enable the meter to be isolated and serviced as required. A by-pass installation also allows purging of the system during commissioning (see Commissioning). The meter must be appropriately rated and is typically located downstream (on the discharge side) of the pump.

Fluid state: Fluid entering the meter must remain a liquid at all times so protect the meter to avoid solidification or gelling of the metered medium. If meters are to be trace heated or jacketed in any way the maximum temperature rating of the meter must not be exceeded. Size the meter to avoid gasification of volatiles (flashing) within the liquid due to the pressure drop experienced within the system or within the meter.

Hydraulic shock: If pressure surges or hydraulic shock of any kind is possible, the system upstream of the meter must be fitted with a surge suppressor or pressure relief valve to protect the meter from damage. High frequency flow pulsations can damage the meter. Such pulsations can be caused by the injection profile in diesel engines. Most pulsations are removed with the installation of a suitable pulsation dampener.

3.0 Commissioning

Once the meter has been mechanically installed the meter is ready for commissioning

The meter must NOT be run until the pipework is flushed of foreign matter, more often than not foreign matter is present after pipework fabrication or modification, weld slag, grinding dust, sealing tape & compound &/or surface rust are most common offenders .

Flushing can be undertaken by utilizing a by-pass or removing the meter from the pipework. If neither is practical then the meter rotors must be removed prior to flushing (refer to Maintenance section of this manual for disassembly).

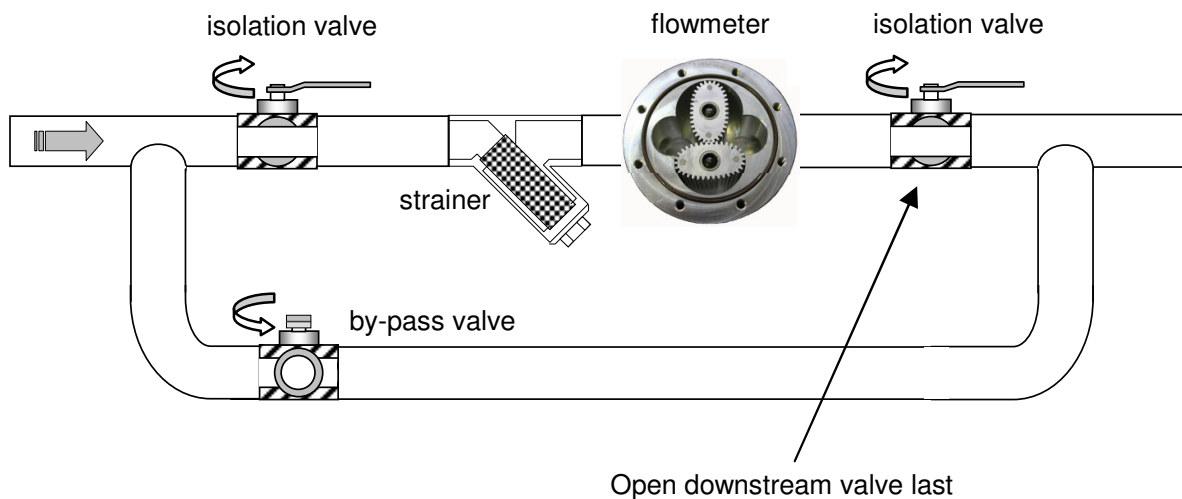

After flushing or following long periods of shutdown the meter must be purged of air/vapour. This can be achieved by allowing the liquid to flow through the meter at a slow rate until all air/vapour is displaced. Never run the meter above its maximum flow or exceed 100kpa (1 bar, 15psi) pressure drop across the meter. Now the meter is ready for its operation to be confirmed by ensuring correct indication on the mechanical display. Refer if necessary to fault finding section of this manual.

4.0 Maintenance

Adhering to the installation instructions in this manual should ensure your meter provides the required operational performance. These are mechanical meters and a periodic maintenance and inspection regime will maximize the operational availability of the meter.

The frequency of maintenance depends on the application factors including liquid lubricity and abrasiveness and operational factors such as flowrate and temperature.

BEFORE undertaking meter maintenance ensure the following:

- Associated alarm(s) or control output(s) are isolated so not to affect the process.
- The meter is isolated from any source of supply of liquid upstream or downstream.
- The meter is depressurized and liquid drained from the meter.

4.1 Disassembly of Meter (Refer Exploded View)

To gain access to the oval geared rotors, undo the 6 body screws (5), carefully pry the meter cap from the meter body, avoiding misplacing or damaging the O-ring (3) or rotors (2).

If it is required to gain access to the internals of the mechanical register and gearbox (within meter cap [4]), you must begin with removal of the mechanical display/register.

In order to access the internal components of the mechanical register, the upper housing screws are removed (12). **Tool required: 4mm Hex Key (Allen Key)**. Once the upper housing (11) is removed, the register gasket (10) should be carefully removed and set aside, followed by the mechanical counter assembly (9). As the counter assembly is retained by the housing; once the upper housing is removed the counter assembly can be easily lifted out of the lower housing (7). When removing the mechanical counter assembly take care not to drop the input shaft or bevel gear, as these components will no longer be retained once the counter is removed from the housing.

The 4 x lower housing screws (8) can now be removed using the same **4mm Hex Key (Allen Key)**.

Do not remove the lower housing screws until your system has been turned off and depressurised; removal of these screws will allow any internal pressure in your system to blow off the lower housing and register plate assembly exposing a wetted area.

Once the lower housing screws are removed, the lower housing (7) and register plate (6) can be removed from the flowmeter. The lower housing will come away from the flowmeter easily; however the register plate is sealed to the flowmeter with an O-Ring so may need to be pried gently off the meter cap, taking care not to damage the mounting faces.

"BEWARE THAT REMOVAL OF ITEM (6) WILL EXPOSE A WETTED CHAMBER WHICH COULD BE UNDER PRESSURE".

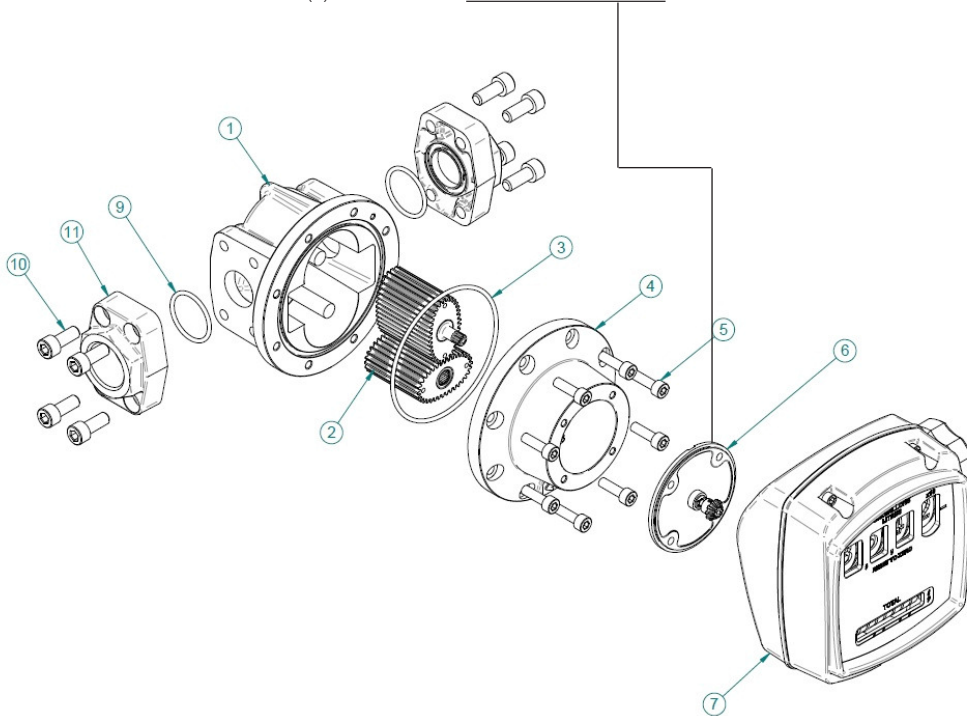

4.2 Inspection (Refer Exploded View)

Inspect O-rings for damage, chemical attack, deformity or any form. Remove, inspect & clean the rotors, check that the primary rotor gear pinion for any damage. Check the measuring chamber for damage or scoring & redress if necessary, the rotor shafts should NOT be loose or able to be rotated.

Inspect the under gears & gear shafts for any wear or damage, check that the gear train rotates freely & that the circlips are in place. Check that the transition gear shaft & bevel gear rotate freely in the register base (6).

4.3 Re-assembly of meter (Refer Exploded View)

When re-installing the rotors the primary rotor with gear pinion must be fitted to the shorter of the two rotor shafts. Both rotors will only engage correctly if fitted precisely at an orientation of 90 degrees to each other. Rotate the rotors slowly by hand to ensure they are correctly fitted at the same time check the rotor shafts & rotor bearings for wear.

Fit the O-ring into the groove and assemble the two parts of the meter, the body & cap align in one position only; this is dictated by the rotor pinion in the 1st rotor.

Fit the body cap screws (5) and tighten in a star sequence then torque in the same sequence to the torque settings stated below. All bolts should be lightly lubricated with a nickel based grease (or other suitable lubricant) prior to re-assembly.

Body Screw Torque settings:

1" (025) Meters: 10 Nm (7.5 ft.lb)

1 1/3" (040) Meters: 20 Nm (15 ft.lb)

2" (050 & 050E) Meters: 20 Nm (15 ft.lb)

This sequence and procedure ensures the meter bodies are assembled correctly and evenly. Fit the register assembly with maintaining original orientation if so desired

4.4 Spare Parts (Refer Exploded View)

Item	Description	1" (025)	1.5" (040)	2" (050)	2" (050E)
1	Body assembly with rotor shafts				
	aluminum	1401109	1401111	1401113	141136
	stainless steel	1401110	1401112	1401135	-
2a #	Primary rotor assembly				
	aluminum rotor + bearing + pinion	1424119	1424127	1424112	1424138
	PPS rotor + pinion	1424236	1424238	1424240	-
	stainless steel rotor + bearings + pinion	1424109	1424168	1424140	-
2b #	Secondary rotor assembly				
	aluminum rotor + bearing + pinion	1424120	1424128	1424113	1424139
	PPS rotor + pinion	1424237	1424239	1424141	-
	stainless steel rotor + bearings + pinion	1424110	1424169	1424141	-
3 #	Body O-ring (Viton Standard)	size BS153V	size BS245V	size BS253V	
	EPR(E) / Buna-N(B) / Teflon encaps. Viton (T)	BS153E/B/T	BS245E/B/T	BS253E/B/T	
4	Meter cap				
	aluminum with gear train	1402069	1402084	1402072	1402094
	stainless steel with gear train	1402095	1402108	1402093	-
5	Body screw (aluminium & stainless steel meters)	M 6x20 (6 pcs)	M 10x25 (8 pcs)	M 10x25 (8 pcs)	
6	Register plate assembly				
	aluminum - Litres	1406047			
	aluminum - US Gallons	1406046			
	stainless steel - Litres	1406048			-
	stainless steel - US Gallons	1406045			-
7	Lower Housing (Die cast aluminium alloy)	1402077			
8	Lower Housing screws (S/S SHCS - 4 pcs)	M 5 x 20			
9	Totaliser assembly (Internal counter mechanism)				
	suit 4 digit register	1432004			
10	Register Gasket (Nitrile Rubber)	1304008			
11	Upper Housing (Die cast aluminium alloy)	1302111			
12	Upper Housing screws (S/S SHCS - 4 pcs)	M 5 x 25			
13	Register facia				
	4 digit - Litres	1315111	1315112		
	4 digit - US Gallons	1315114	1315115		
14	Flange portion O-ring (Viton Standard)	size BS123V	size BS136V	size BS140V	
	EPR(E) / Buna-N(B) / Teflon encaps. Viton (T)	BS123E/B/T	BS136E/B/T	BS140E/B/T	
15	Flange portion screw				
	socket head screw for threaded portions	(M 8 x 20)	(M 10 x 40)	(M 10 x 40)	
	socket head screw for flanged portions	(M 8 x 20)	(M 10 x 30)	(M 10 x 30)	
16	Flange portion kit (includes 2 x flange portions + bolts + viton O-rings)				
	BSP Flange Kit (aluminium)	1522015	-	-	-
	NPT Flange Kit (aluminium)	1522016	-	-	-
	BSP Flange Kit (stainless steel)	1522017	1522021	1522025	
	NPT Flange Kit (stainless steel)	1522018	1522022	1522026	
	Modular Flange - ANSI - 150	1522019	1522023	1522027	
	Modular Flange - DIN Type PN16	1522020	1522024	1522028	
17	Mechanical Register - complete assembly	includes 1 item 7 through 13			
	M3 register assembly (4 Digit - Litres)	1502018	1502026		
	M4 register assembly (4 Digit - US Gallons)	1502022	1502030		

Recommended spare parts

5.0 Fault Finding

Meters have two distinct sections: the mechanical wetted section housing the rotors and reduction gear assembly & the mechanical dry section from the register base (6) out. The aim of fault finding is to trace the source of the fault to one of these two sections.

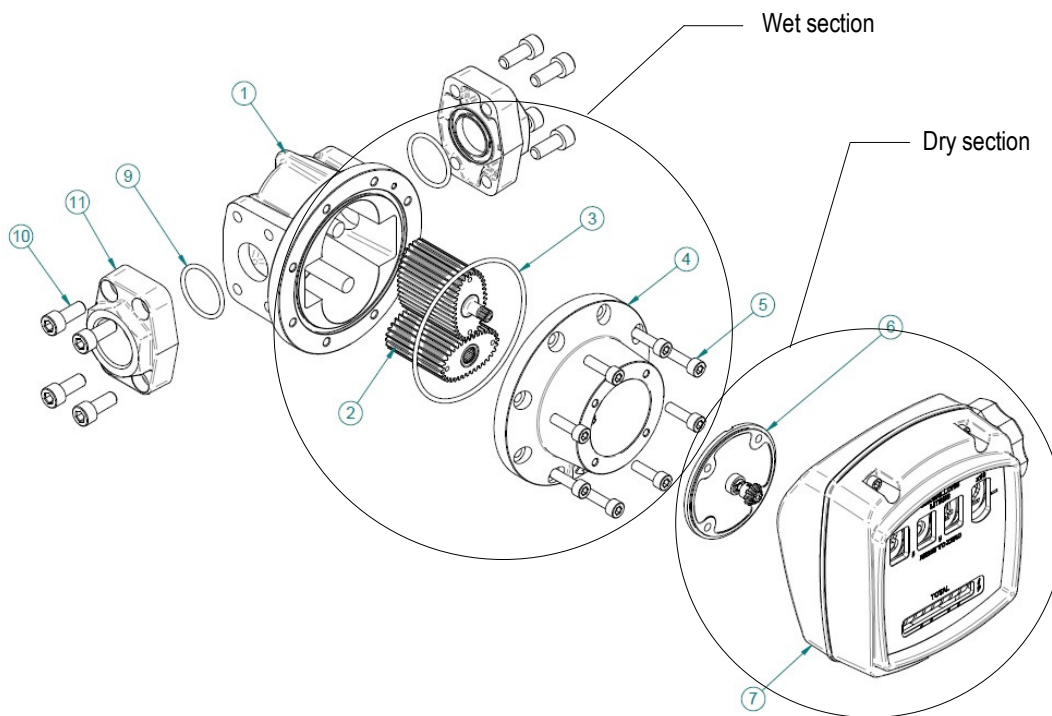

Below are basic fault finding steps. Also refer to Trouble Shooting Guide on following page.

Step 1 - Check application, installation and set-up.

Refer to Mechanical Installation section for installation and application factors that may affect the meter operation including pulsation and air entrainment or incorrect meter selection including incorrect flow rate, temperature and pressure or materials compatibility.

Step 2 - Check for blockages.

The most common cause of fault/unsatisfactory meter operation, particularly for new or altered installations, is due to blockage within the system or meter caused by foreign particles such as weld slag, sealing tape or compound, rust, etc.

Step 3 - Ensure flow is present.

No flow or lower than normal minimum flow may be attributed to a blocked strainer, jammed or damaged rotors within the flowmeter, malfunctioning pump, closed valves or low liquid level in feeder tank.

Step 4 - Ensure oval gears within meter are rotating.

If the register is not totalizing first that the rotors are rotating by holding a screwdriver blade to the meter body and pressing the handle hard against the ear lobe. If necessary test the meter with the flow turned off and turned on to familiarize yourself with the audible rotation signature. If the rotors are rotating then the problem will most probably be somewhere within the reduction gear assembly (within items 4 & 6) or totaliser assembly (9).

5.1 Trouble Shooting

Symptom	Possible Cause	Solution
Meter readings are high	1. Entrained air gas	1. Remove source of air or gas entrapment 2. Install an upstream air eliminator
	2. Pulsating flow from reciprocating style pump	1. Increase back pressure on pump 2. Install a fast response one way check valve 3. Install a surge arrestor between pump & meter 4. Re-calibrate meter in situ to compensate for pulsations 5. Change pump style to smooth delivery type pump
Meter readings are low	1. Damaged or worn rotors	1. Inspect, repair, clean or replace rotors
	2. Damaged or worn measuring chambers	1. Inspect measuring chamber for damage - repair 2. Check concentricity of rotor shafts within chamber
Register no totalising	1. Rotors fouled	1. Check that rounded teeth are towards base of chamber 2. Check for obstruction due to foreign particles 3. Clean, repair or replace rotors
	2. Meter incorrectly reassembled	1. See instructions for reassembly of meter with particular emphasis on positioning of rotors & magnets
	3. Gear train jamed	1. Inspect, repair, clean or replace gear train

Each meter has been calibrated on mineral oil and will contain a small amount of oil residue.

The oil used is Castrol Diesel Calibration Fluid 4113 (product code 055830).