

6 5 4 3 2 1

DRAWING NO **DO NOT SCALE**

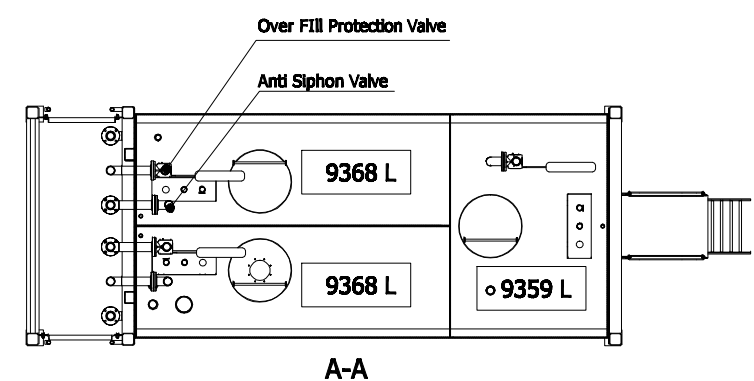
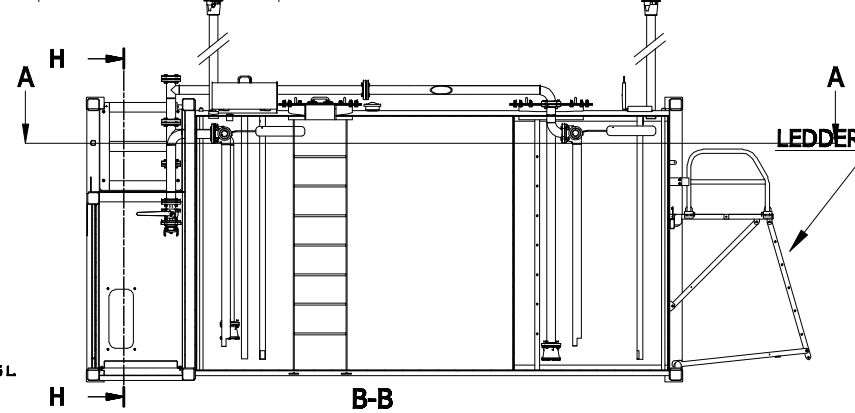
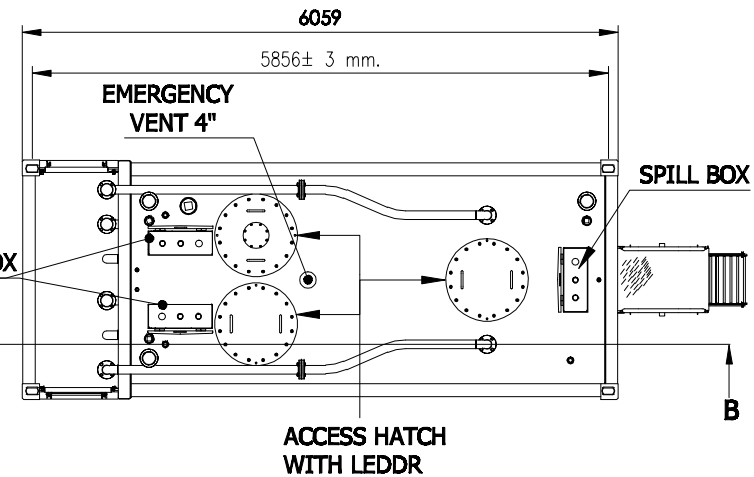
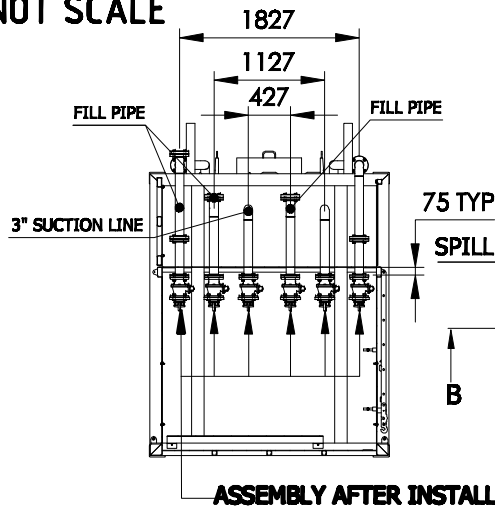
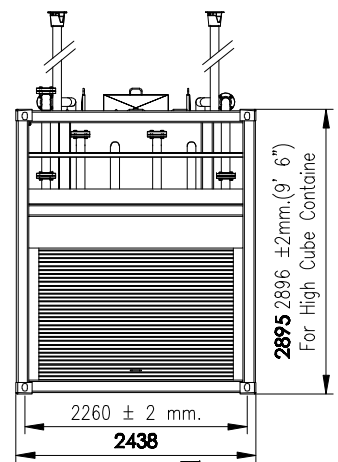

NOTE
 1. ACTUAL VOLUME : 2.816 L
 2. TANK MASS :- Kg
 ALL WELDS TO BE 10 mm.(MIN)
 FILLET OR BUTT WELDS
 UNLESS STATED
 OTHERWISE
 ALL WELDS TO BE : AS1554
 INTERSTITIAL LEAKAGE TEST AT 35 KPA

PART		TOLERANCES: ALL DIMENSIONS IN MM	DRAWN CK	DATE 17-05-2011	LIQUITAINER CO.,LTD		
			DESIGN/CHECKED	DATE			
MATERIAL	CONFIDENTIAL This document and all information contained within it remains the property of LIQUITAINER CO.,LTD and shall not be disclosed or used in any way without the written consent of LIQUITAINER CO.,LTD ©LIQUITAINER CO.,LTD 2010	DRAWN TO AS1100	APPROVED	DATE		DRAWING NO LTT26MC3-DB-001-GA	A3
			CONFIGURED	DATE		SCALE:	

6 5 4 3 2 1