

| Nozzle Schedule | | |
|-----------------|-----------------------------|--|
| Nozzle ID | Connection Type | Service |
| N1 | DN50 - ISO4144 - BSP Socket | Spare (Plugged) |
| N2 | DN50 - ISO4144 - Male | Interstitial Dipstick (Capped) |
| N3 | DN50 - ISO4144 - BSP Socket | Interstitial Vent |
| N4 | DN80 - ISO4144 - BSP Socket | Spare (Plugged) |
| N5 | DN50 - ISO4144 - Male | Secondary Suction (Capped) |
| N6 | DN50 - ISO4144 - BSP Socket | Spare (Plugged) |
| N7 | DN50 - ISO4144 - BSP Socket | Pump Bay Entry (Plugged) |
| N8 | DN80 - ANSI 150 - Flange | Primary Suction Spool With Prime Point |
| N9 | DN50 - ISO4144 - BSP Socket | Pump Bay Entry (Plugged) |
| N10 | DN50 - ISO4144 - Male | Dip (Capped) |
| N11 | DN80 - ANSI 150 - Flange | Primary Fill Spool (c/w Ball Valve, Check Wafer, Type F Camlock and Dustcap) |
| N12 | DN50 - ISO4144 - BSP Socket | Pump Bay Entry (Plugged) |
| N13 | DN50 - ISO4144 - BSP Socket | Spare (Plugged) |
| N14 | DN50 - ISO4144 - BSP Socket | Pump Bay Entry (Plugged) |
| N15 | DN80 - ISO4144 - BSP Socket | Spare (Plugged) |
| N16 | DN50 - ISO4144 - BSP Socket | High Level Alarm |
| N17 | DN200 - Flanged | Interstitial Vent |
| N18 | DN50 - ISO4144 - BSP Socket | Spare (Plugged) |
| N19 | DN200 - Flanged | Pressure Vent |
| N20 | DN50 - ISO4144 - BSP Socket | Free To Air Vent |
| N21 | DN200 - Flanged | Inspection Hatch |
| N22 | DN50 - ISO4144 - BSP Socket | Spare (Plugged) |
| M1 | Flanged (OD=750, ID=600) | Primary Manway |
| M2 | Flanged (OD=900, ID=750) | Secondary Manway |
| M3 | Flanged (OD=750, ID=600) | Tertiary Manway |

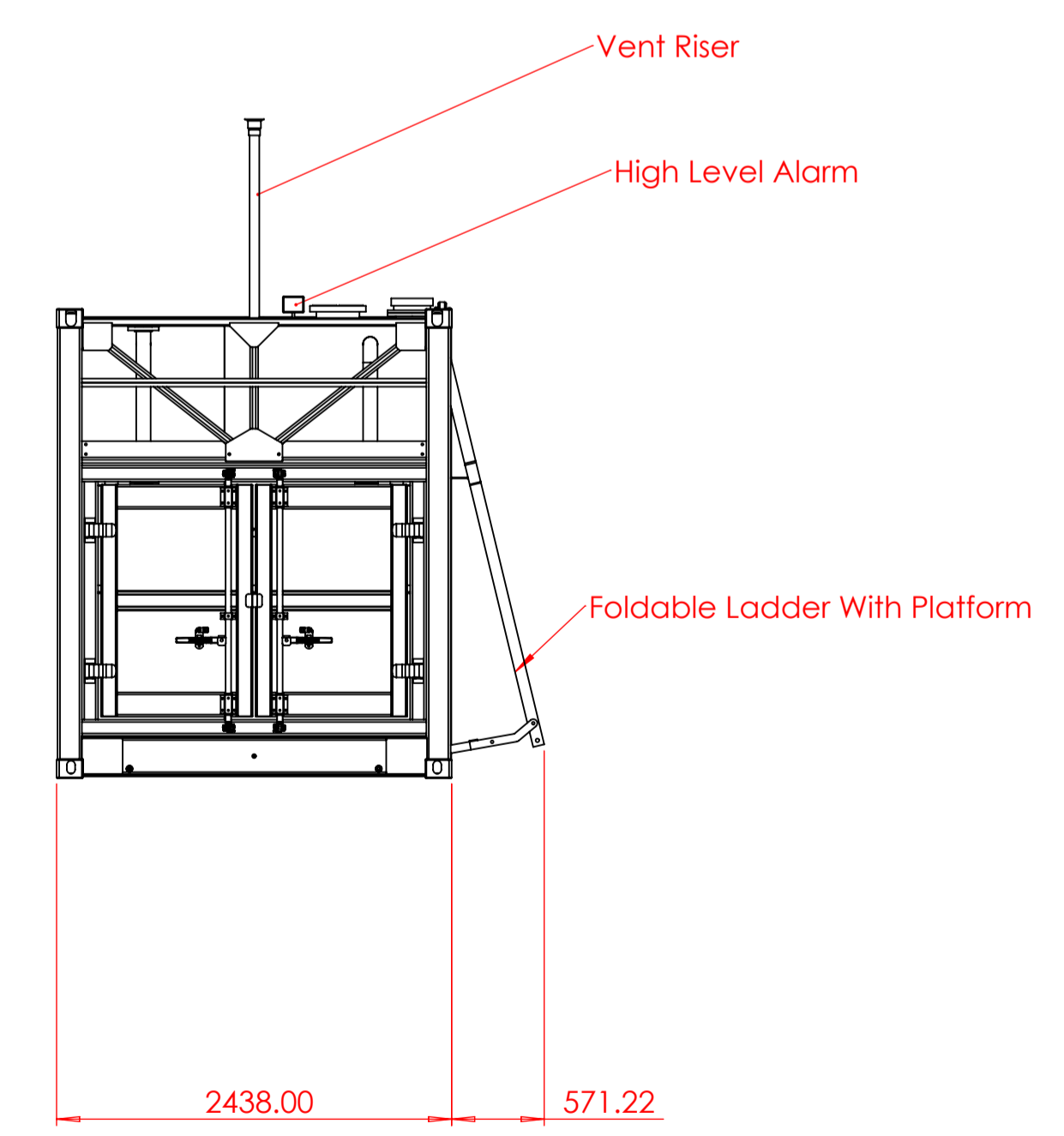
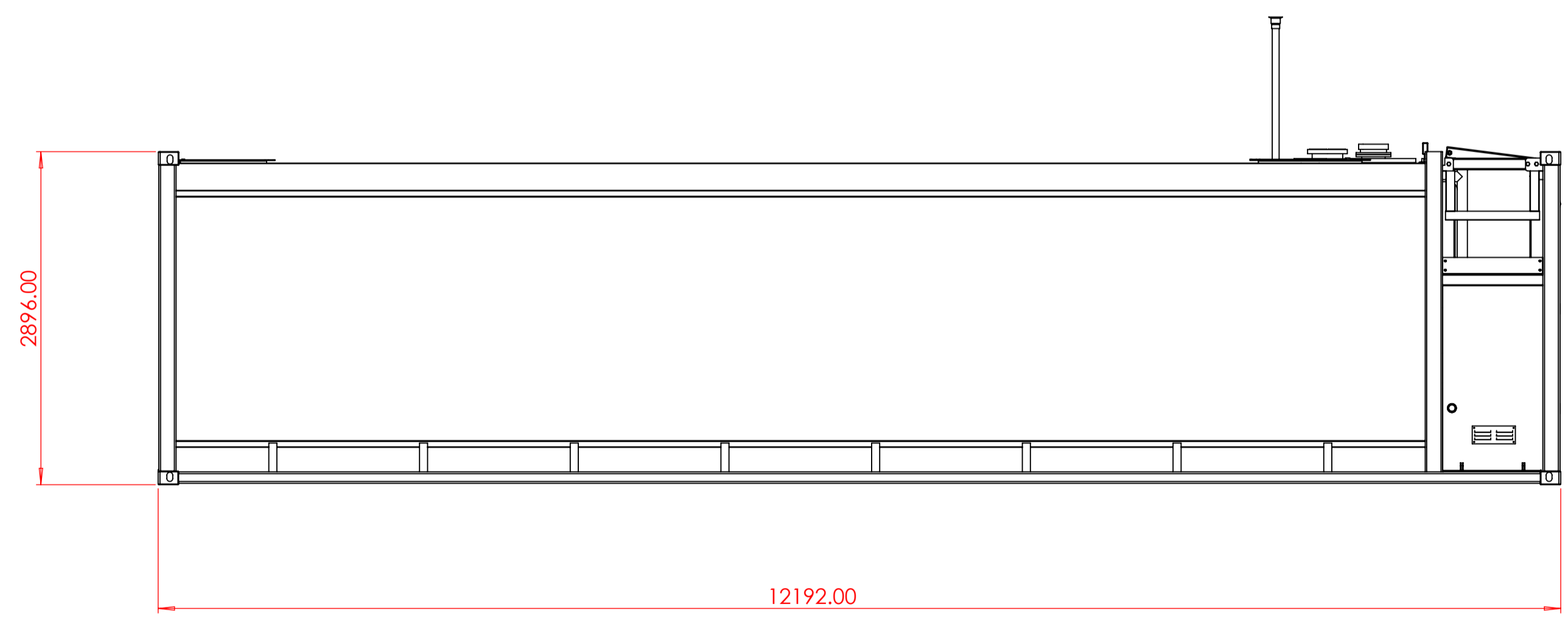

| Tank Data | |
|---------------------|---------------------------|
| DESIGN CODE | AS 1692, AS 1940 |
| BUILT TO | AS 4100, AS 1554 |
| PLATE THICKNESS | 6MM/6MM Q235B |
| EXTERNAL DIMENSIONS | 12192mm x 2438mm x 2896mm |
| GROSS VOLUME | 69023 L |
| SAFE VOLUME | 65570 L |
| NDT | MPT/DPT |
| TARE WEIGHT | 13476 KG |

PETRO INDUSTRIAL GOOD SERVICE
 Factory 2, 106 Potassium street
 PO Box 407
 Narangba QLD 4504
 p: 07 3204 9558
 e: sales@petroindustrial.com.au

COPYRIGHT NOTICE
 This drawing remains property of Petro Industrial Pty Ltd and is not intended for distribution

THIRD ANGLE PROJECTION

TITLE: GA Cover
 DRAWN BY: _____ CHECK DRW: _____
 CLIENT: _____ PROJECT NO: _____
 DRAWING SIZE: A1
 SCALE: 1:40
 DRAWING NUMBER: LT68-GA
 REV. 1

| REV. DATE | REVISION DESCRIPTION | CHKD | APPR | REV. DATE | REVISION DESCRIPTION | CHKD | APPR | REFERENCE DRAWING No. | REFERENCE DRAWINGS |
|-----------|----------------------|------|------|-----------|----------------------|------|------|-----------------------|--------------------|
| | | | | | | | | | |

All dimensions are in mm unless specified otherwise
 Drawn to AS1100.101-1992
 MATERIAL: As Per Manufacturing Drawings
 FINISH: RAL9003: Signal White
 PAGE: 1 OF 1