

Tank Assembly

Nozzle Schedule		
Nozzle ID	Connection Type	Service
N1	DN50 - ISO4144 - BSP Socket	Spare (Plugged)
N2	DN50 - ISO4144 - Male	Interstitial Dipstick (Capped)
N3	DN50 - ISO4144 - BSP Socket	Interstitial Vent
N4	DN80 - ISO4144 - BSP Socket	Spare (Plugged)
N5	DN50 - ISO4144 - Male	Secondary Suction (Capped)
N6	DN50 - ISO4144 - BSP Socket	Spare (Plugged)
N7	DN80 - ANSI 150 - Flange	Primary Suction Spool
N8	DN50 - ISO4144 - Male	Dip (Capped)
N9	DN50 - ISO4144 - BSP Socket	High Level Alarm
N10	DN50 - ISO4144 - BSP Socket	Spare (Plugged)
N11	DN80 - ANSI 150 - Flange	Primary Fill Spool (c/w Ball Valve, Check Wafer, Type F Camlock and Dustcap)
N12	DN80 - ISO4144 - BSP Socket	Spare (Plugged)
N13	DN50 - ISO4144 - BSP Socket	Spare (Plugged)
N14	DN200 - Flanged	Interstitial Vent
N15	DN200 - Flanged	Pressure Vent
N16	DN50 - ISO4144 - BSP Socket	Free To Air Vent
N17	DN200 - Flanged	Inspection Hatch
M1	Flanged (OD=750, ID=600)	Primary Manway
M2	Flanged (OD=900, ID=750)	Secondary Manway

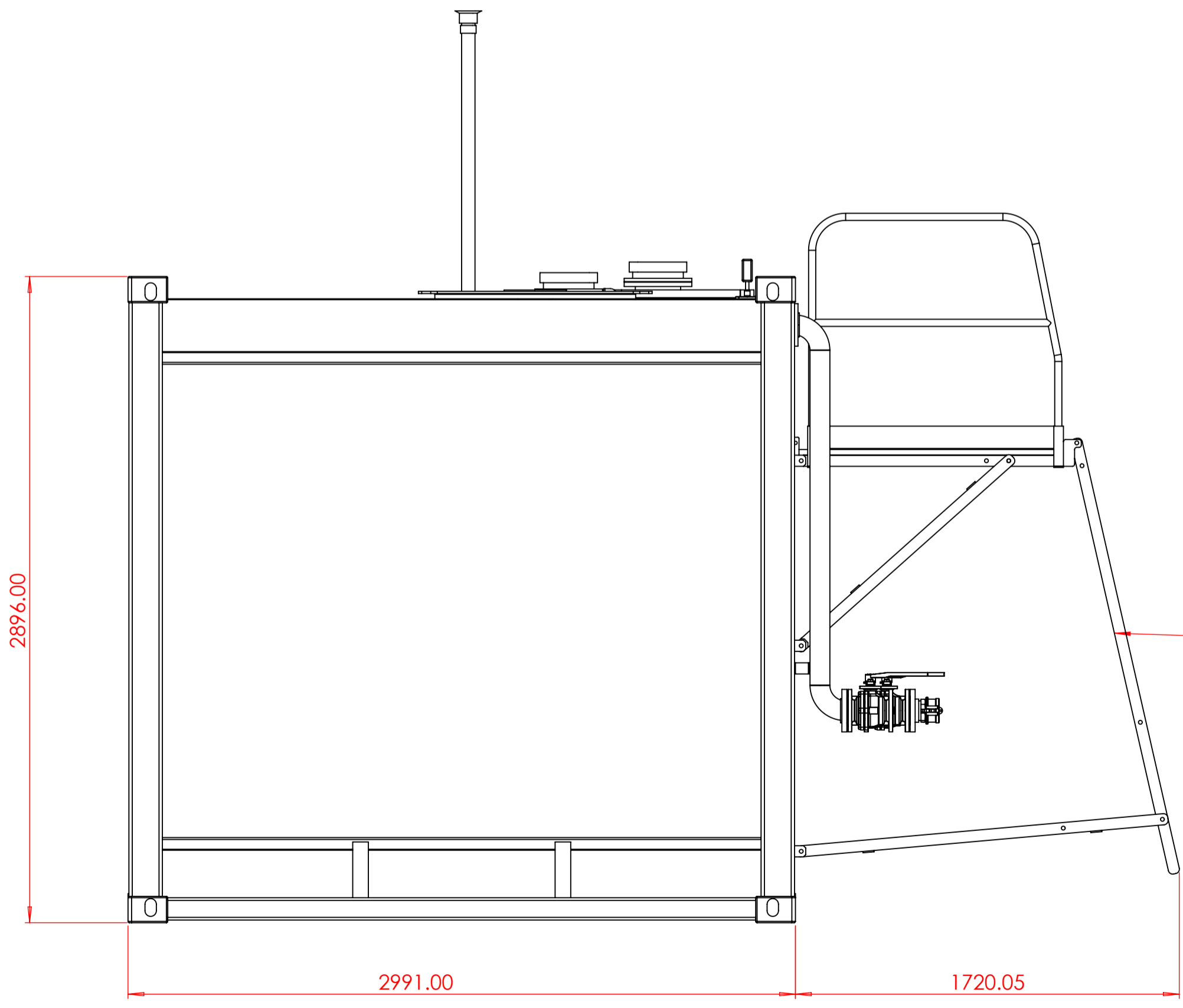

Detachable Ladder

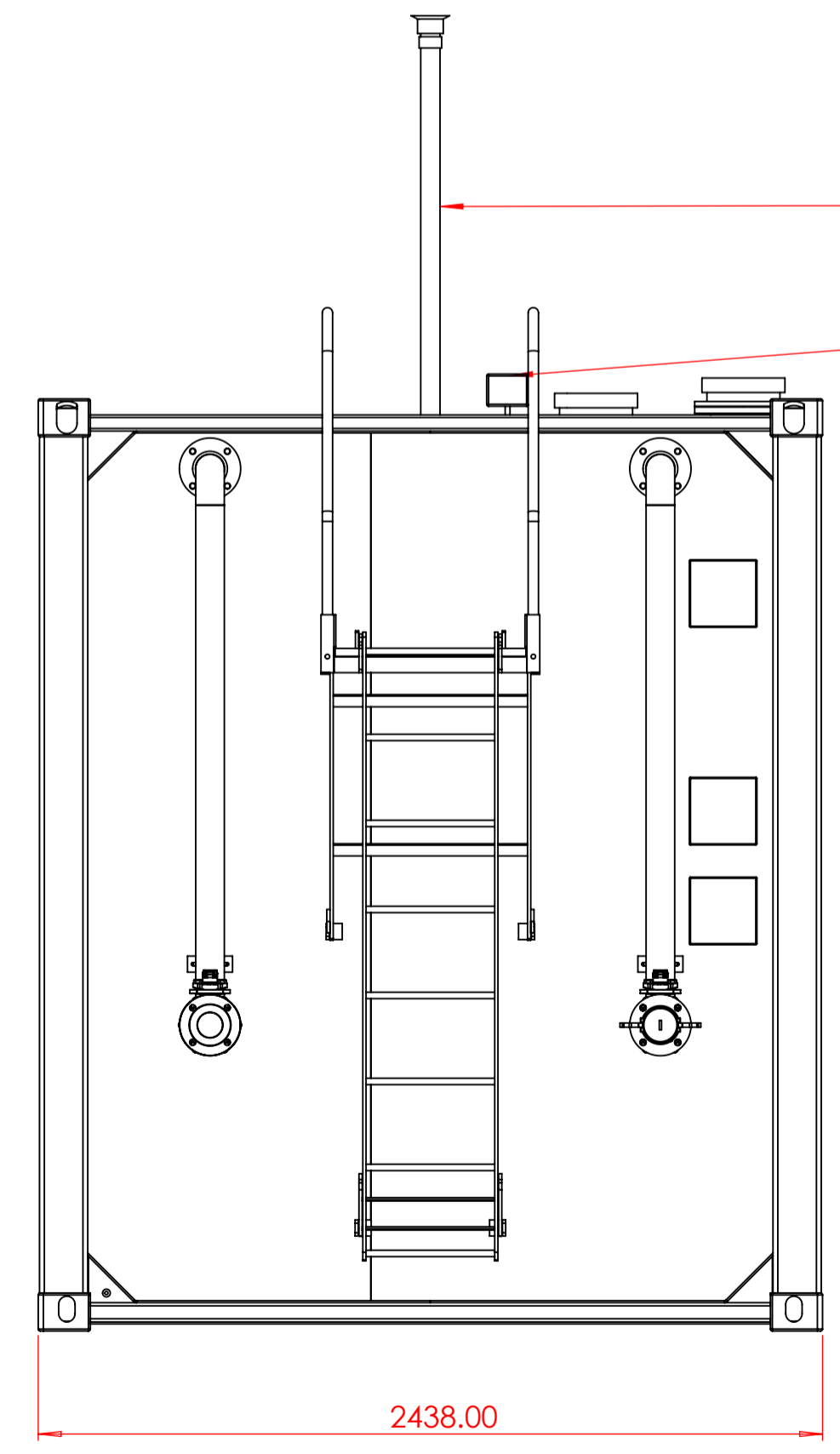

Vent Riser

High Level Alarm

Tank Data	
DESIGN CODE	AS 1692, AS 1940
BUILT TO	AS 4100, AS 1554
PLATE THICKNESS	6MM/6MM Q235B
EXTERNAL DIMENSIONS	2991mm x 2438mm x 2896mm
GROSS VOLUME	18053 L
SAFE VOLUME	17285 L
NDT	MPT/DPT
TARE WEIGHT	4779 KG

PETRO INDUSTRIAL GOOD SERVICE
 Factory 2, 106 Potassium street
 PO Box 407
 Narangba QLD 4504
 p: 07 3204 9558
 e: sales@petroindustrial.com.au

COPYRIGHT NOTICE
 This drawing remains property of Petro Industrial Pty Ltd and is not intended for distribution

TITLE:	GA Cover		
DRAWN BY:	CHECK DRW:	DRAWING SIZE: A1	
CLIENT:	PROJECT NO:	SCALE: 1:20	DRAWING NUMBER: LT20-GA
			REV. 1

REV. DATE	REVISION DESCRIPTION	CHKD	APPR	REV. DATE	REVISION DESCRIPTION	CHKD	APPR	REFERENCE DRAWING No.	REFERENCE DRAWINGS

All dimensions are in mm unless specified otherwise
 Drawn to AS1100.101-1992
 MATERIAL: As Per Manufacturing Drawings
 FINISH: RAL9003: Signal White
 PAGE: 1 OF 1

