



SHIELD-A-SPARK SPARK ARRESTED PUMP HATZ DIESEL ENGINE

DN50 (2") Inlet and Outlet

Item code: 82D1-1B20-X

Gorman-Rupp Shield-A-Spark self-priming centrifugal pumps are the safest approach to handling flammable liquids with an Diesel Engine-driven pump.

FEATURES:

- This unit features dependability, rugged military or aircraft type spark plug which is RFI suppressed and prevents spark gap jumping.
- Shielded ignition wire provides enclosed path for high tension spark.
- Sealed toggle ignition switch is safe and spark-free.
- Spark-arresting muffler is designed to retard both spark and flame.

PUMP SPECIFICATIONS:

- Size: 2" x 2" (51 mm x 51 mm) NPT - Female.
- Casing: Aluminum 356-T6 with Gray Iron 30 Cutwater Insert.
- Maximum Operating Pressure 50 psi (345 kPa).*
- Semi-Open Type, Three Vane Impeller: Aluminum 356-T6. Handles 5/8" (15,8 mm) Diameter Spherical Solids.
- Replaceable Wear Plate: Carbon Steel 1026.
- Intermediate Bracket: Gray Iron 30.
- Shaft Sleeve: Stainless Steel 304.
- Standard Equipment: 90 Ductile Iron Discharge Elbow. Rollover Base with Rubber Feet.
- Seal: Type 21, Mechanical, Self-Lubricated. Carbon Rotating Face. Ni-Resist Stationary Face. Fluorocarbon Elastomers (DuPont Vitonor Equivalent). Stainless Steel 18-8 Cage and Spring. Maximum Temperature of Liquid Pumped, 160F (71C).*
- Flap Valve: Buna-N w/Nylon Reinforcement, Gray Iron 30 and Sintered Powdered Steel. Flange: Gray Iron 30.
- Gaskets: Vegetable Fiber.
- Hardware: Standard Plated Steel.

PETRO INDUSTRIAL



petroind.com



ENGINE SPECIFICATION:

- Model: Hatz 1B20.
- Type: Single Cylinder, Four Cycle, Air Cooled, Diesel Engine.
- Displacement: 14.8 Cu. In. (243 cc).
- Governor: Variable Speed.
- Lubrication: Forced Circulation.
- Air Cleaner: Dry Type.
- Oil Reservoir: 30.4 U.S. Oz. (0,9 liter).
- Fuel Tank: 0.79 U.S. Gal. (3,0 liters).
- Full Load Operating Time: 2.2 Hours.
- Starter: Rope Recoil.
- Muffler Heat Shield and Fuel Splash Guard. 90 Exhaust Deflector. Exhaust Silencer Muffler w / Guard. Grounding Wire.

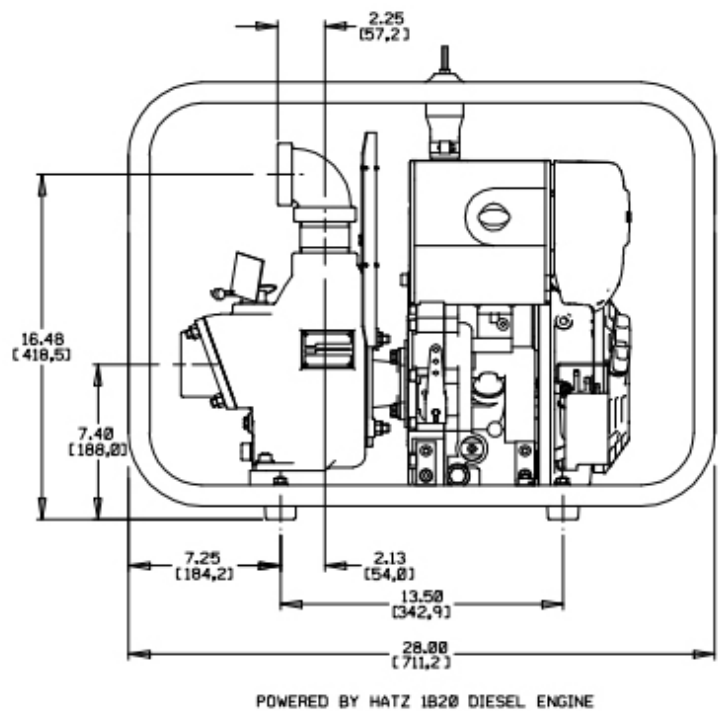
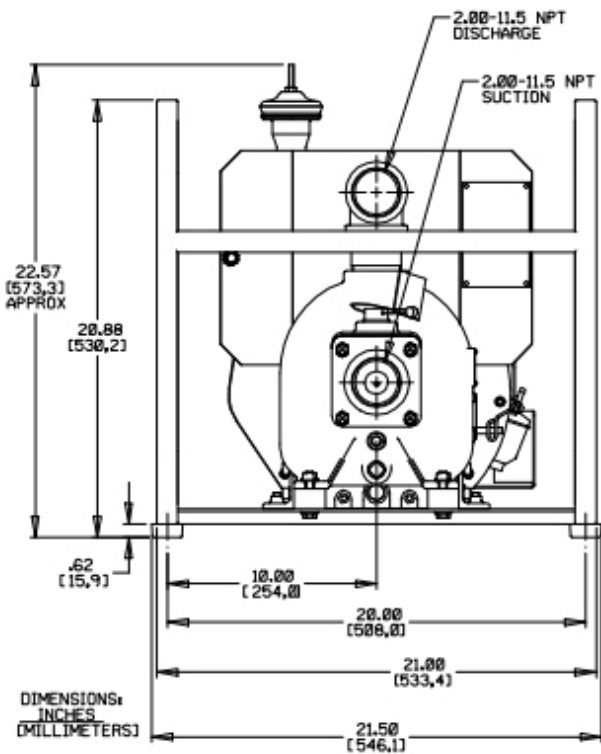

SHIPPING:

- Net Weight: 97 LBS. (44,0 KG.)
- Shipping Weight: 123 LBS. (55,8 KG.)
- Export Crate Size: 5.6 CU. FT. (0,16 CU. M.)