

PETRO INDUSTRIAL



petroind.com



XD SERIES SPRING REWIND HOSE REEL RANGE

Item code: GRACO-XDREEL-DEF

A robust frame, hose length and size are important, but the spring, latch and swivel are really the core of a hose reel. Our new spring design makes it easy to pull down—especially those last 10 feet, and a spring latch that retracts the hose so you don't have to fight to get it to operate.

Plus, a durable full-flow swivel to maximize material flow with minimal pressure drop.

FEATURES:

- Dual Pedestal Frame.
- Metal Spool.
- Rugged, Indoor and Outdoor Use.
- Narrow Footprint.
- Sealed Springs.
- In-Field Spring Adjustment.
- Non-Sparking Ratchet.
- Seale Roller Bearings.
- Long-life spring extends and retracts with constant force to reduce user fatigue.
- Full-Flow Swivel maximize material flow with minimal pressure drop.
- Baked-on enamel finish protects reel from corrosion for longer life – available in six colors.
- Larger Hose Capacity with Smaller Profile.
- Compact pedestal and spool fits into tight spaces and can accommodate.
- 35-65 foot (10-20 meters) hose capacity for a wide variety of applications
- Improved Latch Design.
- No more frustrating lock-out at full hose extension.
- Increase or decrease spring tension while reel is pressurized with fluid.

PETRO INDUSTRIAL



petroind.com



PRODUCT RANGE:

Application		Part Number by Colour				Pressure Psi (bar)	Hose		Connection Size		Operating Temp.		
		Blue	White	Yellow	Sand		ID in	Length	Inlet in	Outlet in			
Air, Water, Anti-freeze, Windshield Washer Fluid	SIZE 10	HSL25B	HSL25A	HSL25F	HSL25G	300(20.7)	3/8	50 (15)	1/2npsm(m)	3/8npt(m)	-20-190°F (-20-87°C)		
		HSL33B	HSL33A	HSL33F	HSL33G		1/2	95 (11)		1/2npt(m)			
	SIZE 20	HSL56B	HSL56A	HSL56F	HSL56G		3/8	65 (20)		3/8npt(m)			
		HSL65B	HSL65A	HSL65F	HSL65G		1/2	50 (15)		1/2npt(m)			
	SIZE 30	HSLC8B	HSLC8A	HSLC8F	HSLC8G			75 (23)		3/4	3/4npsm(m)	3/4npt(m)	-40-180°F (-40-82°C)
		HSLD5B	HSLD5A	HSLD5F	HSLD5G		50 (15)						
Petroleum, Synthetic Based Oils	SIZE 10	HSM33B	HSM33A	HSM33F	HSM33G	2,000(138)	1/2	35 (11)	1/2npsm(m)	1/2npt(m)	-20-190°F (-28-87°C)		
		HSM3BB*	HSM3BA*	HSM3BF*	HSM3BG					1/2npt(f)			
	SIZE 20	HSM65B	HSM65A	HSM65F	HSM65G					50 (15)		1/2npt(m)	
		HSM6DB*	HSM6DA*	HSM6DF*	HSM6DG							1/2npt(f)	
	SIZE 30**	HSMC8B	HSMC8A	HSMC8F	HSMC8G	1,500(103)	3/4	75 (23)	3/4npsm(m)	1/2npt(m)	-40-180°F (-40-82°C)		
		HSMCFB*	HSMCFA*	HSMCFF*	HSMCFG*	2,000(138)				1/2npsm(f)			
		HSMDB*	HSMDDA*	HSMDDF*	HSMDDG*	1,250(86)	50 (15)	3/4npt(m)					
		HSMDDB*	HSMDDA*	HSMDDF*	HSMDDG*	2,000(138)		3/4npsm(f)					
Grease	SIZE 10	HSH15B	HSH15A	HSH15F	HSH15G	5,000(345)	1/4	50 (15)	3/8npsm(m)	1/4npt(m)	-40-200°F (-40-93°C)		
		HSH1DB*	HSH1DA*	HSH1DF*	HSH1DG*					3/8npt(f)			
	SIZE 20	HSH55B	HSH55A	HSH55F	HSH55G	4,000(276)	3/8	35 (11)		1/4npt(m)			
		HSH5DB*	HSH5DA*	HSH5DF*	HSH5DG*					3/8npsm(f)			
	SIZE 30**	HSHC5B	HSHC5A	HSHC5F	HSHC5G	5,000(345)	1/2	50 (15)		1/2npsm(m)		1/2npt(m)	-40-180°F (-40-82°C)
		HSHCDB*	HSHCDA*	HSHCDF*	HSHCDG*					1/2npsm(f)			
Pressure Wash	SIZE 30	HSPB8B	HSPB8A	HSPB8F	HSPB8G	4,000(276)	3/8	75 (23)	1/2npsm(m)	3/8npt(m)	-20-225°F (-28-107°C)		
		HSHFFB*	HSHFFA*	HSHFFF*	HSHFFG*					3/8npsm(f)			
Fuel/ Evacuation	SIZE 30	HSLE3B	HSLE3A	HSLE3F	HSLE3G	125(8.6)	1	30 (9)	3/4npsm(m)	1npt(m)	-40-120°F (-40-49°C)		

Maximum dry weight with hose: XD10 = 54 lbs (24.5 kg), XD20 = 59 lbs (27 kg), XD30 = 98 lbs (44.5 kg)

Wetted parts–Bare hose reel only: zinc plated steel, anodized aluminum, nitrile rubber

Instruction Manuals: XD10 and XD20: 313431, XD30: 3A0138

* Bare reel–hose sold separately / ** Not recommended for overhead installation. Maximum installed height is 7 feet (2.13 meters).

PETRO INDUSTRIAL



petroind.com



DIMENSIONS:

	Size 10	Size 20
A	7.5 in (196 mm)	7.5 in (196 mm)
B	16.2 in (412 mm)	18.1 in (460 mm)
C	21.0 in (533 mm)	23.4 in (594 mm)
D	18.0 in (457 mm)	20.0 in (508 mm)
E	18.5 in (470 mm)	21.0 in (533 mm)
F	22.5 (571 mm)	25.2 in (640 mm)

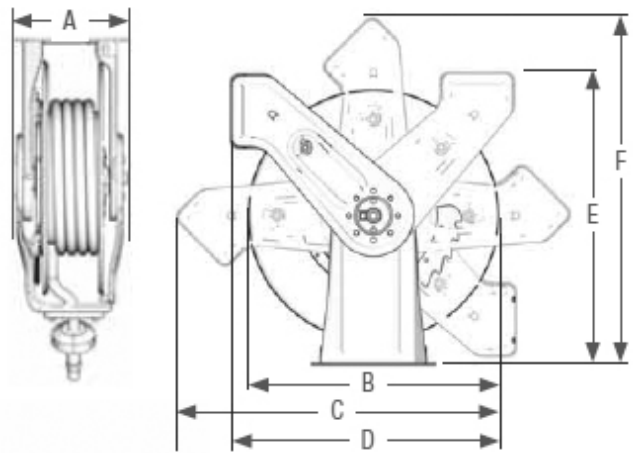

DIMENSIONS:

	Size 30
A	9.0 in (229 mm)
B	21.50 in (546.00 mm)
C	25.96 in (659.45 mm)
D	22.12 in (561.73 mm)
E	23.10 in (588.00 mm)
F	27.60 in (700.82 mm)

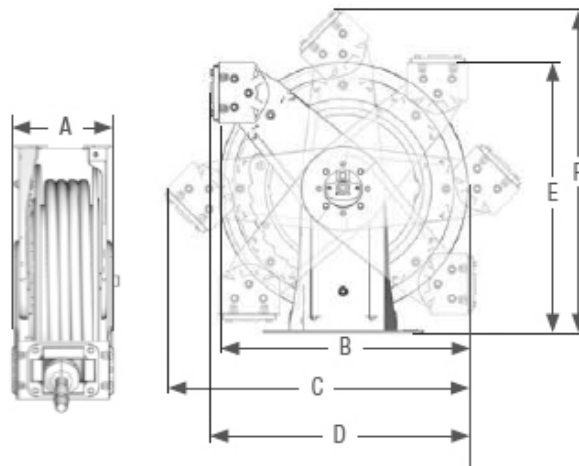



ACCESSORIES:



Mounting Channels

Enclosure mounting channels accommodate one, two, three, four, five or six reels (includes all parts needed to mount hose reels to walls or ceilings)

XD10 and XD20	1 Reel	2 Reels	3 Reels	4 Reels	5 Reels	6 Reels
Code	24A219	24A220	24A221	-	-	24A222



Mounting Bracket

Code	Description
204741	Secures mounting channel to I-beam without drilling. Two brackets are required for 1-3 hose reels; three brackets for 4-6 hose reels.



Ball Stop Kits

Code	Typical Hose ID
222225*	For 1/4 in (6.4 mm) i.d. hose
218340*	For 1/4-3/8 in (6.4-9.5 mm) i.d. hose
218341*	For 3/8-1/2 in (9.5-12.7 mm) i.d. hose
237873	For 3/4 in (19 mm) i.d. hose
237874	For 1 in (25 mm) i.d. hose
24D132	For 3/8 in (9.5 mm) o.d. hose
24D133	For 1/2 in (12.7 mm) o.d. hose

*Not for use with XD30 reels



Hose Inlet Kits

Code	Description	Pressure psi (bar)	Hose ID in (mm)	Length in (mm)	Hose Inlet
218549	Low /medium pressure	2000 (137)	1/2 (12)	24 (610)	npt(m)
218550	High pressure	4000 (276)	3/8 (10)	24 (610)	npt(m)
222417	High pressure	5000 (345)	1/4 (6)	24 (610)	npt(m)